

MAXIMO MX 18

Panel Formwork 270 / 330

Instructions for Assembly and Use – Standard Configuration

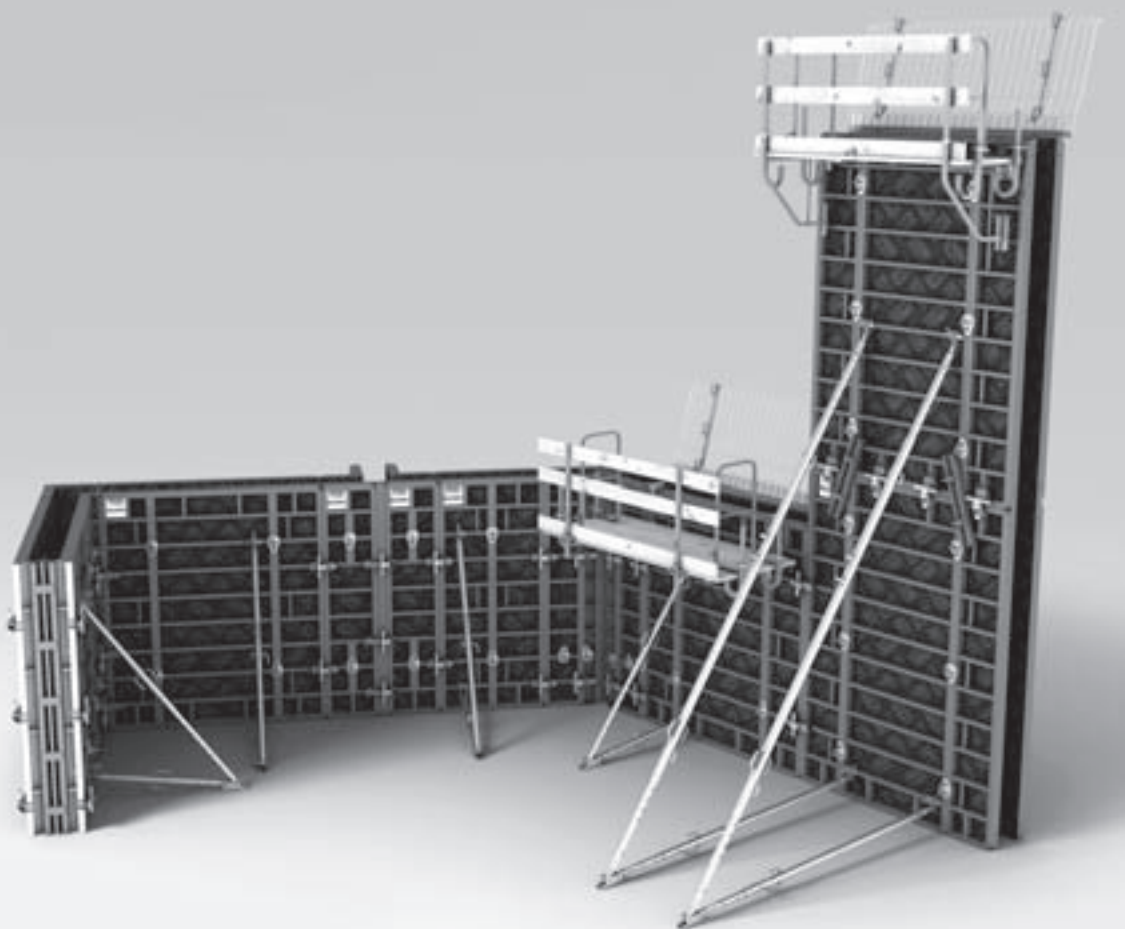

Overview

Main Components	1
Key	2

Introduction

Target Groups	3
Additional Technical Documentation	3
Intended Use	4
Care and Maintenance Instructions	5

Safety Instructions

Cross-System	6
System-Specific	7
Storage and Transportation	7

General

A1	Storage and Transportation	
	– Stacking Device MX	8
	– Stacking Aid MXI, MXA, MX Flat	9
A2	Quick User Guide	10
A3	Panels	12
A4	Panel Connections	
	– Alignment Coupler BFD	16
	– Compensation Waler MAR	17
A5	Tie Technology	
	– Tie System MX 18	18
	– Tie System DW	20
	– Inclined Ties	21
	– Closing Tie Points	22
A6	Push-Pull Props, Kickers	
	– Permissible Width of Influence	24
	– Brace Connector	25
	– Push-Pull Props and Kickers	25
A7	Work and Concreting Scaffolds	
	– Concreting Platform 120/270	26
	– Scaffold Bracket TRG	29
	– Guardrails	31
A8	Downward Extensions	32
A9	Parapets, Foundations, Beams	
	– Tension and Compression Brace	34
	– Foundation Strap	35
A10	Height Offsets	36
A11	Obtuse Wall Connection	36
	Vertical / Horizontal Wall Connections	37

Standard Configuration MX 18, Height 270 cm

B1	90° Corners with Inside Corner MXI 18, 270 x 50/20	
	– Wall Thicknesses 15 – 40 cm	38
	– Wall Thicknesses > 40 – 60 cm	40
B2	Panel Connections following 90° Corners	42
B3	90° T-junctions with Inside Corner MXI 18, 270 x 50/20	
	– Wall Thicknesses 15 – 40 cm	44
	– Wall Thicknesses > 40 – 60 cm	46
B4	Panel Connections following 90° T-junctions	48
B5	Length Compensations	49

B6	Stopend Formwork Stopend Panel for Reinforcement	50
	– without water bar installation – MT	52
	– with water bar installation – MTF	53
	– with expandable water bar	53
B7	Extensions	54

Standard Configuration MX 18, Height 330 cm

C1	90° Corners with Inside Corner MXI 18, 330 x 50/20	
	– Wall Thicknesses 15 – 40 cm	56
	– Wall Thicknesses > 40 – 60 cm	58
C2	Panel Connections following 90° Corners	60
C3	90° T-junctions with Inside Corner MXI 18, 330 x 50/20	
	– Wall Thicknesses 15 – 40 cm	62
	– Wall Thicknesses > 40 – 60 cm	64
C4	Panel Connections following 90° T-junctions	66
C5	Tension and Compression Brace	68
C6	Length Compensations	69
C7	Stopend Formwork	
	– with Panel MX 18, 330 x 30	70
	– with timber and filler plywood	71
C8	Extensions	72

Supplementary System Components

D1	Magnet Cone MX 18	74
D2	90° Corners with Inside Corner MXI 18, 270/330 x 60	
	– Wall Thicknesses 15 – 30 cm, MXA 270/300 x 35	76
	– Wall Thicknesses 30 – 40 cm, MXA 2700 x 45	76
	– Wall Thicknesses > 40 – 60 cm	78
D3	90° T-junctions with Inside Corner MXI 18, 270/330 x 60	
	– Wall Thicknesses 15 – 40 cm	80
	– Wall Thicknesses > 40 – 60 cm	82
D4	90° Corners for 80 cm Wall Thickness	
	– with Inside Corner MXI 18, 270/330 x 50/20	84
	– with Inside Corner MXI 18, 270/330 x 60	86
D5	Shaft Formwork Shaft Corner MXSE 18 Crane Lifting Gear	88
	– Lifting Hook MAXIMO 1.5 t	89
	– Lifting Gear Combi MX	89
	Shaft Corner MXSE 18, 270	90
	Shaft Corner MXSE 18, 330	92
	Shuttering / Striking	94
	Wall Thicknesses	96
	Extensions	97
D6	Sealing Replacement	
	– Removing the sealing	98
	– Inserting the sealing	99

Components

MX 18 Panel Formwork 270 / 330	100
--------------------------------	-----

Main Components

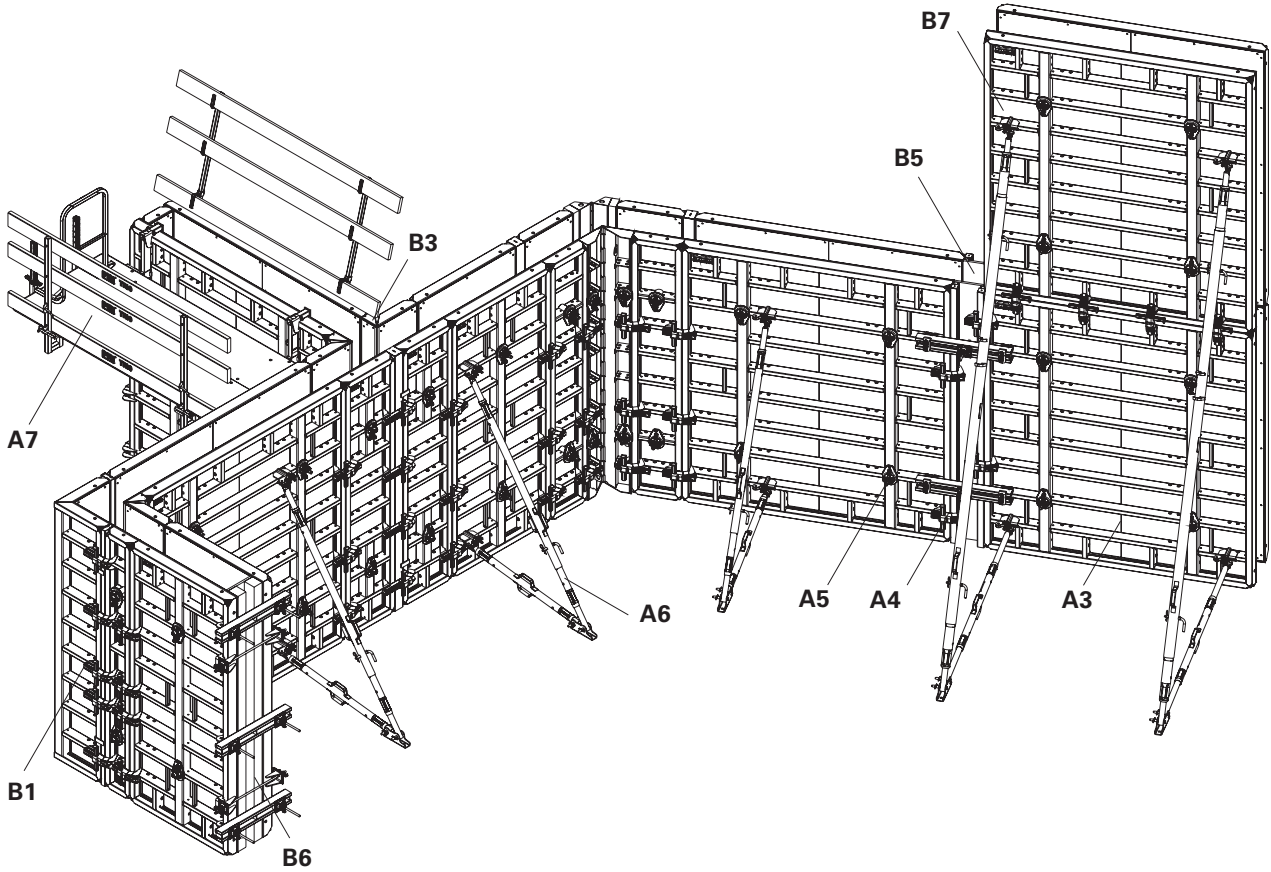

- A3 Panels
- A4 Panel Connections
- A5 Anchor Technology
- A6 Push-Pull Props, Kickers
- A7 Work and Concreting Scaffold
- B1 90° Corners
- B3 90° T-junctions
- B5 Length Compensations
- B6 Stopped Formwork
- B7 Extensions

Key

Pictogram | Definition

 Safety instructions

 Note

 Visual check

 Tip

 Load-bearing point

 Misapplication

Dimension specifications

Dimensions are usually given in cm.
Other measurement units, e.g. m, are shown in the illustrations.

Conventions

- Instructions are numbered with:
1. , 2. , 3.
- The result of an instruction is shown by: → Position numbers are clearly provided for the individual components and are given in the drawing, e.g. 1, in the text in brackets, for example, (1). Multiple position numbers, i.e. alternative components, are represented with a slash, e.g. 1 / 2.

Presentational reference

The illustration on the front cover of these instructions is understood to be a system representation only. The assembly steps presented in these Instructions for Assembly and Use are shown in the form of examples with only one component size. They are valid accordingly for all component sizes contained in the standard configuration.

For a better understanding, detailed illustrations are partly incomplete. The safety installations which have possibly not been featured in these detailed drawings must nevertheless be available.

Target Groups

Contractor

These Instructions for Assembly and Use are designed for contractors who use the formwork systems for

- assembling, modifications and dismantling or
- e.g. concreting or
- for other operations, e.g. carpentry or electrical work.

Construction site coordinator

The Safety and Health Protection Coordinator*

- is appointed by the client,
- must identify potential hazards during the planning phase,
- determines measures that provide protection against risks,
- creates a safety and health plan,
- coordinates the protective measures for the contractor and site personnel so that they do not endanger each other,
- monitors and ensures compliance with the protective measures.

* Valid in Germany: Regulations for Occupational Health and Safety on Construction Sites 30 (RAB 30).

Qualified and competent personnel

Due to the specialist knowledge gained from professional training, work experience and recent professional activity, the qualified person has a reliable understanding of safety-related issues and can correctly carry out tests.

Depending on the complexity of the test to be undertaken, e.g. scope of testing, type of testing or the use of a certain measuring device, a range of specialist knowledge is necessary.

Qualified specialists

Formwork systems may only be assembled, modified or dismantled by personnel who are suitably qualified to do so. For the work to be carried out, the qualified workers must have received instructions** which contain at least the following points:

- An explanation of the plan for the assembly, modification or dismantling of the formwork system in an understandable form and in the language of the user.
- Description of measures in order to safely assemble, modify or dismantle the formwork system.
- Designation of the preventive measures to avoid the risk of persons and objects falling.

** Instructions are given by the contractor himself or a qualified and competent person selected by him.

- Designation of the safety precautions in the event of changing weather conditions which could adversely affect the safety of the formwork system concerned as well as the personnel.
- Details regarding the permissible loads.
- Description of any other risks that are associated with the assembly, modification or dismantling procedures.



In other countries, ensure that the relevant national guidelines and regulations in the respective current version are complied with!

Additional Technical Documentation

- Instructions for Use
 - Lifting Hook MAXIMO 1.5 t
 - Lifting Gear Combi MX
 - Lifting Gear MX
 - Pallets and Stacking Devices
 - Concrete Cones
 - PERI Bio Clean
- Data Sheet for Anchor Bolt 14/20 x 130
- PERI Design Tables – Formwork and Shoring
- MAXIMO Brochure

Intended Use

Product description

PERI products have been designed for exclusive use in the industrial and commercial sectors only by suitably trained personnel.

The MAXIMO wall formwork system is a flexible panel formwork made of steel for residential and industrial construction projects.

With MAXIMO, concrete components can be produced, e.g. walls and foundations.

MAXIMO has the following features:

- Neat tie and joint arrangement.
- Centrally-positioned tie point for different tie systems. One-sided tie technology with spacing adjustment.
- Panel connections with BFD Alignment Coupler – also possible in area of ties.
- Rigid external corners for wall thicknesses from 20 – 60 cm.
- Formlining panels are riveted.
- Compatible with PERI TRIO.

Technical data

- Panel heights: 330, 270, 120, 90, 60 and 30 cm.
- Panel widths: 240, 120, 90, 60, 45 and 30 cm.
- Perm. load of platform and brackets: 150 kg/m².

Permissible fresh concrete pressure according to DIN 18218

Evenness according to DIN 18202, Table 3, Line 7.

Fresh concrete pressure	Height	Tie System MX 18* / DW 20
Hydrostatic pressure Triangular load	2.70 m	67.5 kN/m ²
	3.30 m	82.5 kN/m ²
Constant load Uniformly distributed load	2.70 m	80.0 kN/m ²
	3.30 m	80.0 kN/m ²

* Tie System MX 18 is only valid for panel connections with wall thicknesses ≤ 60 cm. Tie System DW 20 is valid for all wall thicknesses.

Perm. fresh concrete pressure 80 kN/m² for 90° corners and 90° T-junctions for wall thicknesses > 40 cm: assembly only with Tie System DW 20 – Walers SRU and ties throughout – see Section D4.

Instructions for Use

The use in a way not intended, deviating from the standard configuration or the intended use according to the Instructions for Assembly and Use, represents a misapplication with a potential safety risk, e.g. risk of falling.

Only PERI original components may be used. The use of other products and spare parts is not allowed.

Changes to PERI components are not permitted.

Care and Maintenance Instructions

In order to maintain the value and operational readiness of the formwork materials over the long term, clean the elements after each use.

Some repair work may also be inevitable due to the tough working conditions.

The following points should help to keep care and maintenance costs as low as possible.

Spray the formwork on both sides with the concrete release agent before each use; this allows easier and faster cleaning of the formwork. Spray the concrete release agent very thinly and evenly!

Spray the rear side of the formwork with water immediately after concreting; this avoids any time-consuming and costly cleaning operations.

When used continuously, spray the panel formlining with the concrete release agent immediately after striking; then clean by means of a scraper, brush or rubber lip scraper. Important: do not clean formlining made of plywood with high-pressure equipment; this could result in the formlining being damaged.

Fix box-outs recesses and mounting parts with double-headed nails; as a result, the nails can be easily be subsequently removed, and damage to the formlining is largely avoided.

Close all unused anchor holes with plugs; this eliminates any subsequent cleaning or repair work. Anchor holes accidentally blocked with concrete are freed by means of a steel pin from the formlining side.

When placing bundles of reinforcement bars or other heavy objects on horizontally-stored formwork elements, suitable support, e.g. square timbers, is to be used; as a result, impressions and damage to the formlining are largely avoided.

Internal concrete vibrators should be fitted, if possible, with rubber caps; as a result, any damage to the formlining is reduced if the vibrator is accidentally inserted between the reinforcement and formlining.

Never clean powder-coated components, e.g. elements and accessories, with a steel brush or hard metal scraper; this ensures that the powder-coating remains intact.

Use spacers for reinforcement with a large-sized supports or extensive areas of support; this largely avoids impressions being formed in the formlining when under load.

Mechanical components, e.g. spindles or gear mechanisms, must be cleaned of dirt or concrete residue before and after use, and then greased with a suitable lubricant.

Provide suitable support for the components during cleaning so that no unintentional change in their position is possible.

Do not clean components when suspended on a crane.

Cross-System

General

The contractor must ensure that the Instructions for Assembly and Use supplied by PERI are available at all times and are understood by the site personnel.

These Instructions for Assembly and Use can be used as the basis for creating a risk assessment. The risk assessment shall be compiled by the contractor. The Instructions for Assembly and Use do not replace the risk assessment!

Always take into consideration and comply with the safety instructions and permissible loads.

For the application and inspection of PERI products, the current safety regulations and guidelines must be observed in the respective countries where they are being used.

Materials and working areas are to be inspected on a regular basis especially before each use and assembly for:

- signs of damage,
- stability and
- functionality.

Damaged components must be exchanged immediately on site and may no longer be used.

Safety components are removed only when they are no longer required.

Components provided by the contractor must conform with the characteristics required in these Instructions for Assembly and Use as well as all valid construction guidelines and standards. Unless otherwise indicated, this applies in particular to:

- timber components: Strength Class C24 for Solid Wood according to EN 338,
- scaffold tubes: galvanised steel tubes with minimum dimensions of $\varnothing 48.3 \times 3.2$ mm according to EN 12811-1:2003 4.2.1.2,
- scaffold tube couplings according to EN 74.

Deviations from the standard configuration are only permitted after a further risk assessment has been carried out by the contractor. On the basis of this risk assessment, determine appropriate measures for working and operational safety as well as stability.

Corresponding proof of stability can be provided by PERI on request if the risk assessment and resulting measures to be implemented are made available.

Before and after exceptional occurrences that may have an adverse effect on the safety of the formwork system, the contractor must immediately

- create another risk assessment, with appropriate measures for ensuring the stability of the formwork system being carried out based on the results,
- and arrange for an extraordinary inspection by a qualified and competent person. The aim of this inspection is to identify and rectify any damage in good time in order to guarantee the safe use of the formwork system.

Exceptional occurrences can include:

- accidents,
- longer periods of non-use,
- natural events, e.g. heavy rainfall, icing, heavy snowfall, storms or earthquakes.

Assembly, modification and dismantling work

Assembly, modification or dismantling of formwork systems may only be carried out by qualified personnel under the supervision of an authorized person. The qualified personnel must have received appropriate training for the work to be carried out with regard to specific risks and dangers.

On the basis of the risk assessment and Instructions for Assembly and Use, the contractor must create installation instructions in order to ensure safe assembly, modification and dismantling of the formwork system.

The contractor must ensure that the personal protective equipment required for the assembly, modification or dismantling of the system, e.g.

- safety helmet,
 - safety shoes,
 - safety gloves,
 - safety glasses,
- is available and used as intended.

If personal protective equipment (PPE) is required or specified in local regulations, the contractor must determine appropriate load-bearing points on the basis of the risk assessment.

The personal protective equipment to be used is determined by the contractor.

The contractor must

- provide safe working areas for site personnel which can be reached through the provision of safe access ways. Areas of risk must be cordoned off and clearly marked,
- ensure the stability during all stages of construction, in particular during assembly, modification and dismantling of the formwork,
- ensure and prove that all loads are safely transferred.

Utilization

Every contractor who uses or allows formwork systems or sections of the formwork to be used, has the responsibility to ensure that the equipment is in good condition.

If the formwork system is used successively or at the same time by several contractors, the health and safety coordinators must point out any possible mutual hazards and all work must be then coordinated.

System-Specific

Retract components only when the concrete has sufficiently hardened and the person in charge has given the go-ahead for striking to take place.

Anchoring is to take place only if the anchorage has sufficient concrete strength.

During striking, do not tear off the formwork elements with the crane.

If a storm warning is given, additional push-pull props are to be attached or other bracing measures are to be carried out along with implementing the bracing specified in the PERI design tables.

Storage and Transportation

Store and transport components ensuring that no unintentional change in their position is possible. Detach load-bearing devices and lifting gear from the components that have been set down only if they are in a stable position and no unintentional change is possible.

Do not drop the components.

Use PERI load-bearing devices and lifting gear as well as only those load-bearing points provided on the component.

During the moving procedure,

- ensure that components are picked up and set down so that unintentional falling over, falling apart, sliding, falling down or rolling is avoided,
- no persons are allowed to remain under the suspended load.

The access areas on the jobsite must be free of obstacles and tripping hazards as well as being slip-resistant.

For transportation, the surface must have sufficient load-bearing capacity.

Use original PERI storage and transport systems, e.g. crate pallets, pallets or stacking devices.

Transport



- The panels should never be treated with a concrete release agent immediately before transport due to safety reasons.
- Manually-created transport units must be correctly stacked and secured!
- Instructions for Use for PERI Pallet and Stacking Devices must be followed at all times!

PERI pallets and stacking devices are suitable for lifting by crane or forklift. They can also be moved with the PERI Pallet Lifting Trolley. All pallets and stacking devices can be lifted using both the longitudinal and front sides.

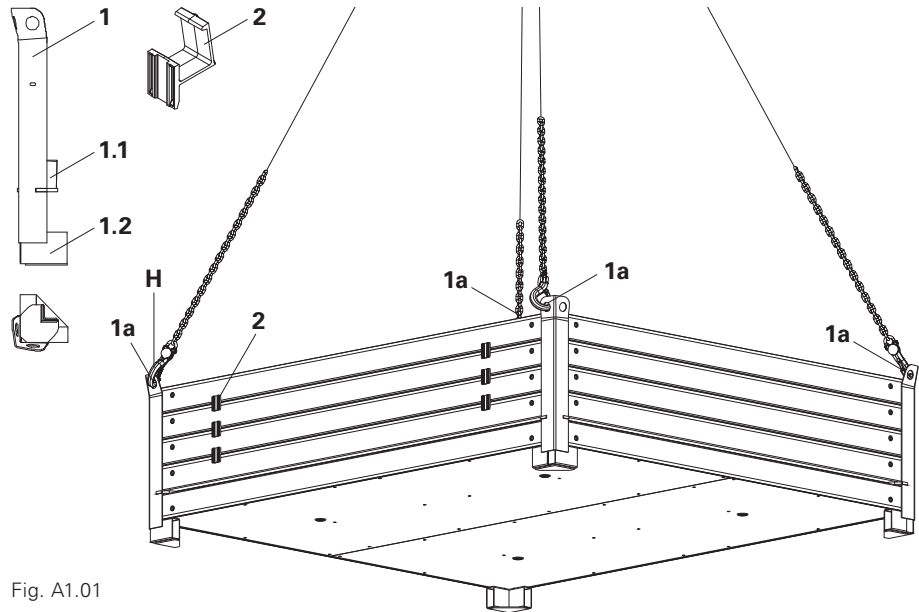

Fig. A1.01

Pos.	Aids	Item no.
1	Stacking Device MX	115058
2	Stacking Aid MX	113019

Stacking Device MX



- Only panels of the same size are to be transported in one stack!
- Use 4-sling lifting gear. On each stacking device, attach a hook (H) to one load-bearing point (1a).
→ Four load-bearing points (Fig. A1.01)

Perm. load-bearing capacity

650 kg/device = 2.6 t/stack.

Number of panels per stack

2 – 5 MAXIMO panels of one size with all-round 6 cm edge profile.

Crane sling angle $\leq 45^\circ$

4-sling lifting gear L = 3.0 m. (Fig. A1.01)

Stacking height

3 stacks, one on top of the other.

Putting loads into the stacking device

1. Place the first panel with the formlining facing downwards on the rectangular tube (1.2). (Fig. A1.02)
2. Place the second panel with the formlining facing upwards in the stacking device. (Fig. A1.03)
→ The vertical support plate (1.1) positions the panel and now allows safe transportation of the panels.
3. Position Stacking Aid MX (2) – 2 per longitudinal side.
→ Formlining is protected.
4. Place other panels with the formlining facing upwards.
5. Alternatively place stacking aids and panels until the maximum number of panels has been reached.

Panel removal

Remove panels individually with locking pins of the transport lifting gear.

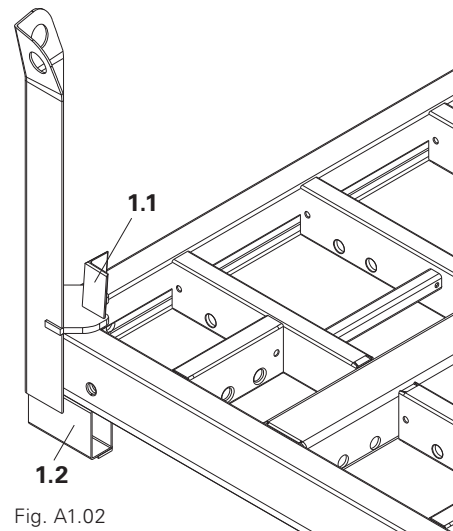

Fig. A1.02

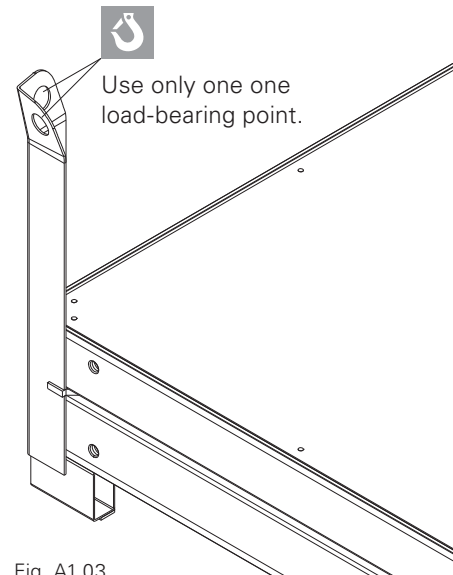

Fig. A1.03

Stacking Aids MXI, MXA, and MX Flat



Stacking aids

- are not transport safety devices!
- are used as transport safety devices only in combination with transport belts.

Pos.	Component	Item no.
3	Stacking Aid R MXI	118112
4	Stacking Aid L MXI	118110
5	Stacking Aid R MXA	118105
6	Stacking Aid L MXA	118103
7	Stacking Aid MX Flat	118100

Stacking Aid MXI



Take into account there are right and left versions.

Inside Corners MXI 18, height x 50/20

- Stack with
- two shaft corners (not shown),
 - four shaft corners: install stacking aids only on the corners. (Fig. A1.04a)

Inside Corners MXI 18, height x 60

- Stack with
- two shaft corners, (Fig. A1.04b)
 - four shaft corners: install stacking aids only on the corners. (not shown)

Stacking Aid MXA



Take into account there are right and left versions.

Outside Corners MXA height x 45 or MXA height x 35

(Fig. A1.05)

Stacking Aid MX Flat

For Shaft Corners MXSE 18 x height

- Stack with
- two shaft corners: install stacking aids on the corners at the top and bottom, (Fig. A1.06a)
 - four shaft corners: install Stacking Aids MX Flat (7) only on the corners at the bottom. (Fig. A1.06b + A1.06c)

Push back positioning waler for stacking, and secure. (Fig. A1.06c)

MXI

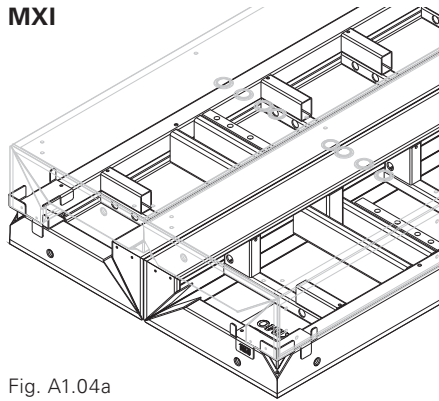

Fig. A1.04a

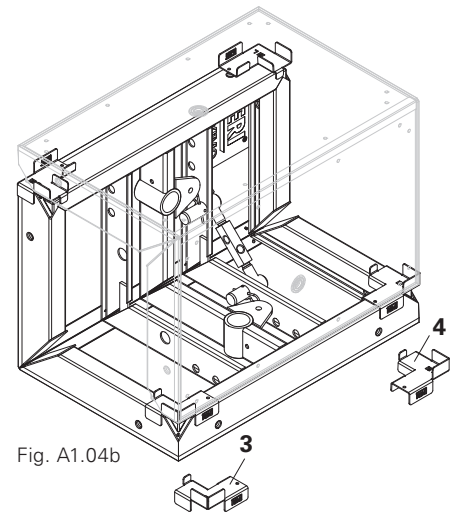

Fig. A1.04b

MXA

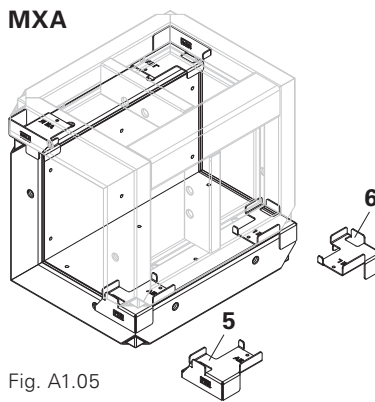

Fig. A1.05

MX Flat

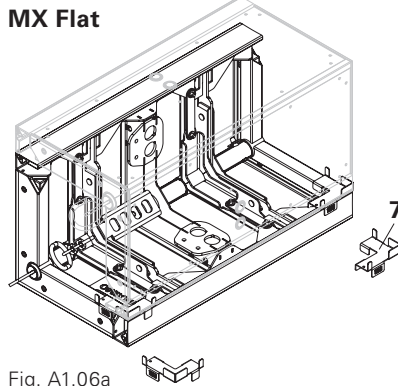

Fig. A1.06a

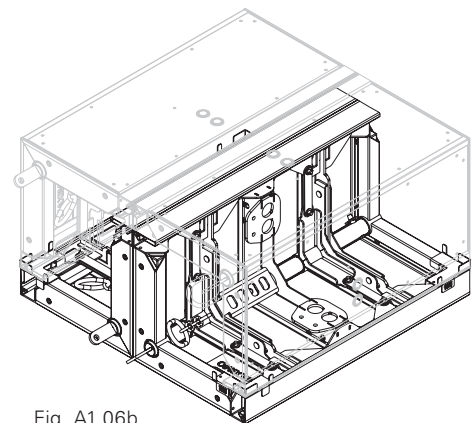

Fig. A1.06b

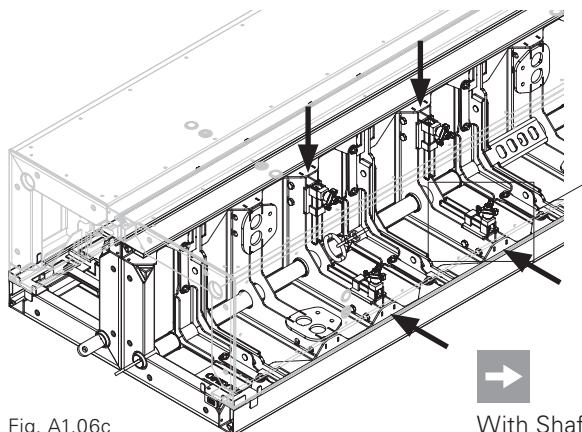
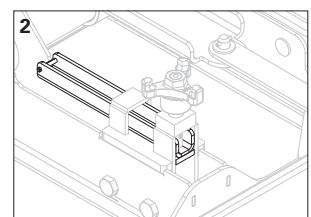
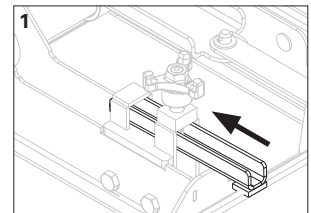

Fig. A1.06c



With Shaft Corners MXSE 18 height > 120, turn the top panel. (not shown)

Assemble placing formwork



- **Secure panels with push-pull props to prevent tipping over and counter wind forces!**
- **Secure push-pull props first, and then release crane lifting gear!**

1. Insert all swivel nuts in the tie points. (Fig. A2.01)
2. Tighten eyebolts of the swivel nuts.
3. Mount push-pull props, see Section A6.
 - On the first panel: 2 push-pull-props. (Fig. A2.02)
 - Second panel onwards: 1 push-pull prop. (Fig. A2.05)
4. Mount Lifting Hook MAXIMO 1.5 t.
5. Attach the 2-sling lifting gear.
6. Transport panel to place of operation by crane. (Fig. A2.03)
7. Secure push-pull prop, see Section A6.
8. Release crane lifting gear.

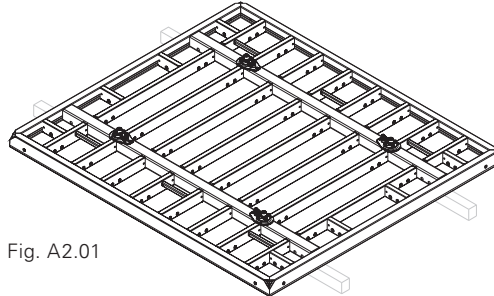

Fig. A2.01

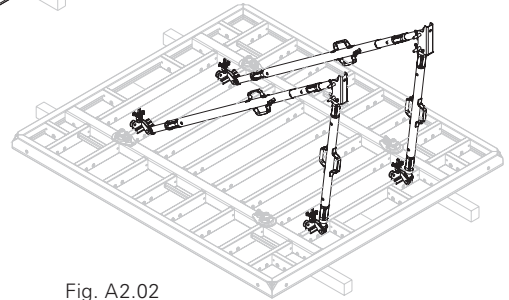

Fig. A2.02

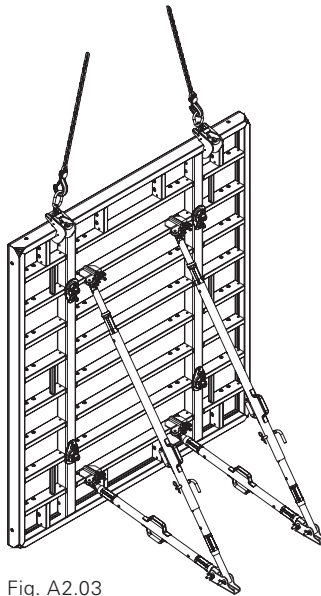

Fig. A2.03

Mount closing formwork with work and concreting scaffold



- Install top anchor first, and then release the crane lifting gear!**

1. Mount the work and concreting scaffold on the horizontally-positioned panel, see Section A7.
2. Install decking and guardrails. (Fig. A2.04a + A2.04b)
3. Mount Lifting Hook MAXIMO 1.5 t.
4. Transport panel to place of operation by crane.
5. Install anchor, see Section A5.
6. Release crane lifting gear.

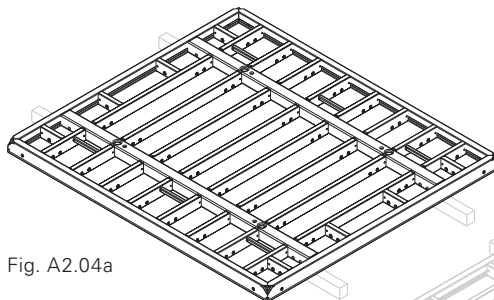

Fig. A2.04a

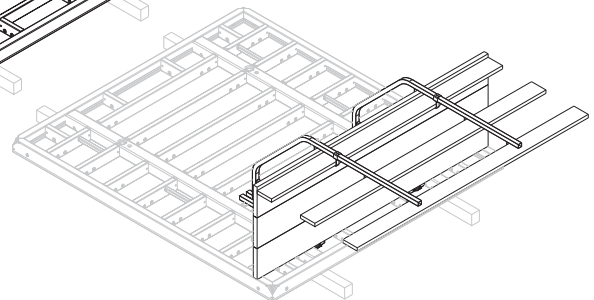

Fig. A2.04b



Forming from the external or internal corner in the direction of the compensation.

Concreting

From a secure working scaffold.
(Fig. A2.05)

Striking and moving

from the compensation to the corners.



- **Wear personal protective equipment (PPE) to prevent falling from a height.**
- **Before moving, dismantle the work and concreting scaffold!**
- **Concrete strength must be taken into account!**
- **Secure panels against tipping over and wind forces!**
- **Secure push-pull props first, and then release crane lifting gear!**

Releasing the closing formwork

1. Dismantle work and concreting scaffold.
2. Mount Lifting Hook MAXIMO 1.5 t on the panel and attach to crane lifting gear.
3. Remove ties.
4. Release panel connection.
5. Release panel from the concrete, e.g. with a stripping bar.
6. Carefully lay the panel down and clean.

Moving the primary formwork

1. Dismantle opposing guardrails.
 2. Mount Lifting Hook on the panel and attach to the crane lifting gear.
 3. Release panel connection.
 4. Remove anchor bolts of the push-pull props.
 5. Release panel from the concrete, e.g. with a stripping bar.
 6. Carefully lay the panel down and clean.
 7. Move panel to place of installation by crane.
 8. Connect panel with the Alignment Coupler BFD, see Section A4.
 9. Secure push-pull props, see Section A6.
 10. Release crane lifting gear.
- (Fig. A2.06)

Closing the formwork

1. Move panel of the closing formwork to the place of installation by crane.
2. Connect panels.
3. Install anchors.
4. Release crane lifting gear.
5. Mount work and concreting scaffold.

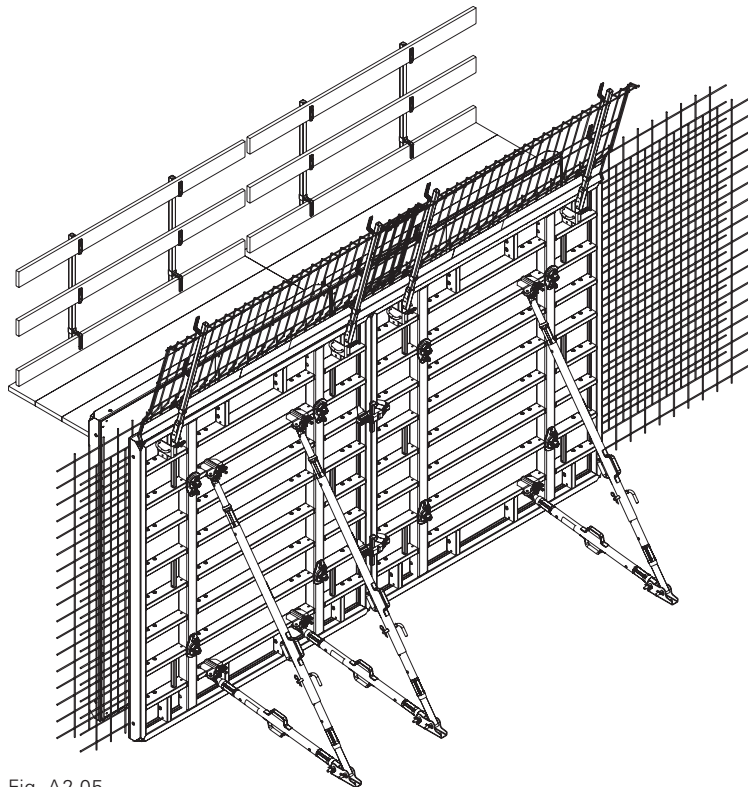

Fig. A2.05

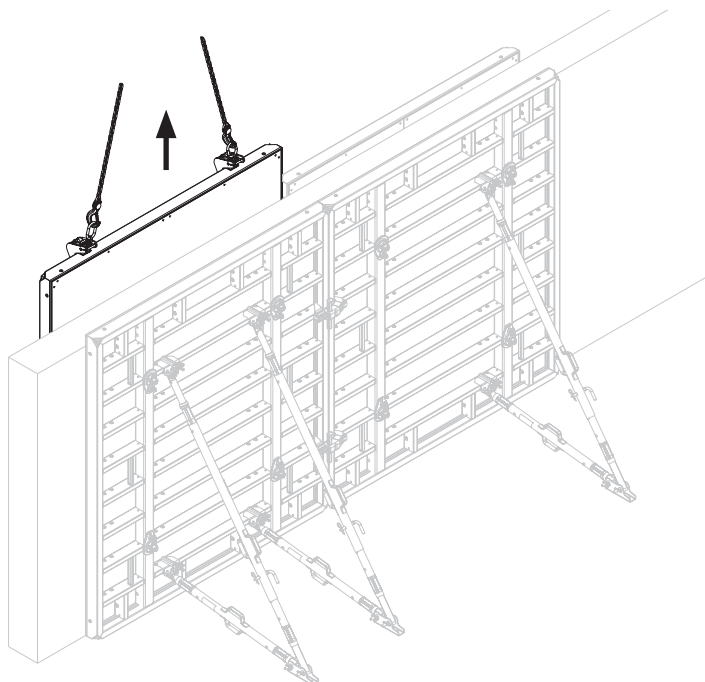

Fig. A2.06

Cleaning

with PERI Bio Clean and release agent spraying equipment.



Consider PERI Bio Clean operating instructions!

		Width [cm]					
		240	120	90	60	45	30
Height [cm]	30						
	60						
	90						
	120						
	270						
	330						

A3 Panels

	Inside Corner MXI 18, 50/20	Outside Corner MXA 45

Multi-Purpose Panel MXM 18, 60	Inside Corner MXI 18, 60	Outside Corner MXA 35

Panel Width 240 cm



Do not use the positioning strut (10.5) for transporting with the crane!

Do not use the positioning strut as a climbing aid!

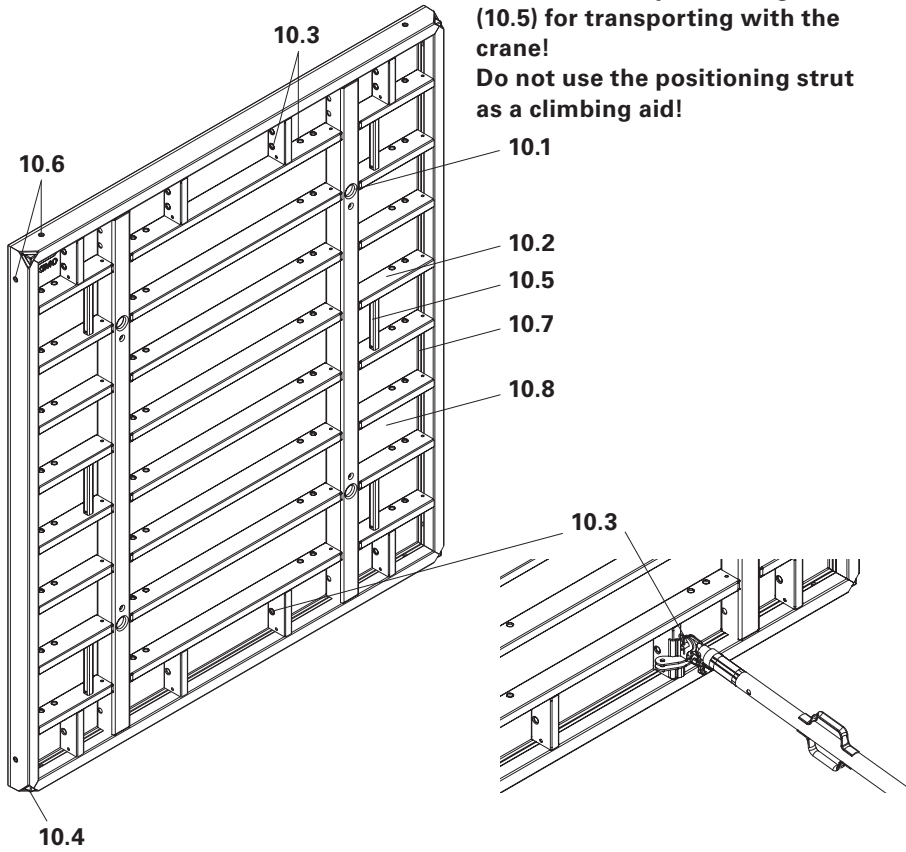

Panel Width 120 cm

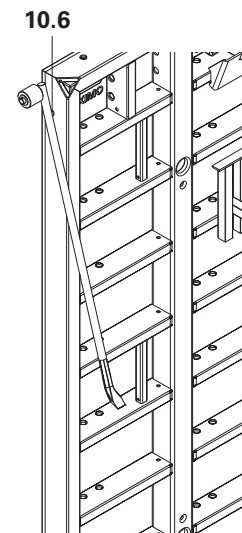
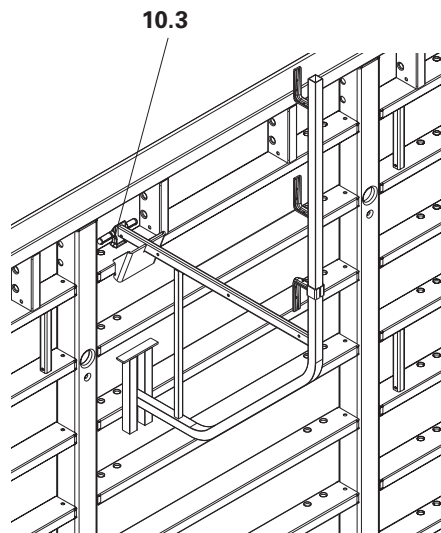
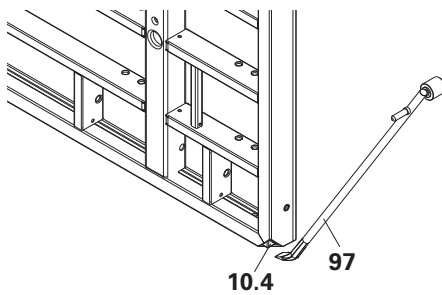
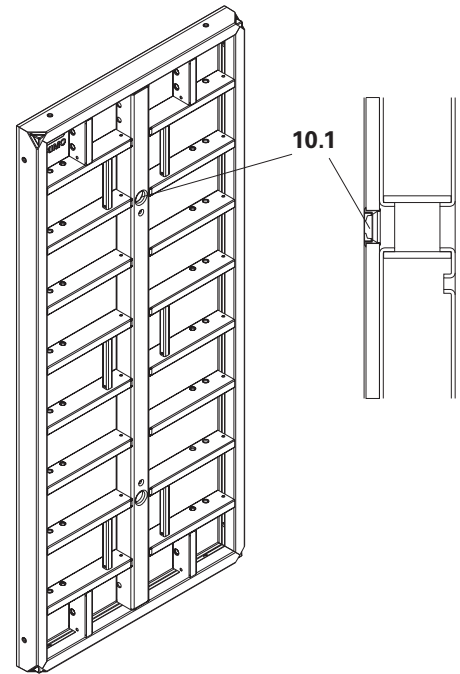

- (10.1) Tie point with sealing
- (10.2) Panel strut
- (10.3) Connecting hole possibilities for scaffold brackets, push-pull props and other accessories
- (10.4) Levering corner
- (10.5) Positioning strut for positioning the panel
- (10.6) Transportation opening, e.g. for stripping lever
- (10.7) Frame
- (10.8) Formlining
- (97) Stripping lever

Alignment Coupler BFD

Item No. 023500 (Fig. A4.01a)

Height (H)	BFD standard joint	MXI 18, H x 50/20	MXI 18, H x 60	Length compensations	Stopend Formwork	Extensions
		see Section				
270 cm	2 pieces	B1+B3	D2+D3	B5	B6	B7
330 cm	3 pieces	C1+C3	D2+D3	C6	C7	C8

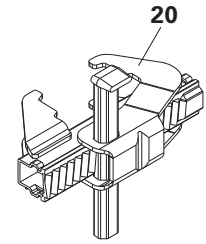

Fig. A4.01a

Assembly

1. Place wedge in upper end position.
2. Open sliding part. (Fig. A4.01b)
3. Place BFD on panel strut.
4. Close sliding part.
5. Secure wedge. (Fig. A4.02a)
→ The Alignment Coupler is now securely in position.

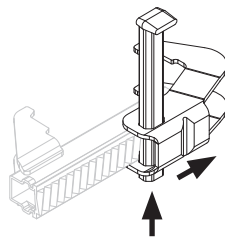

Fig. A4.01b

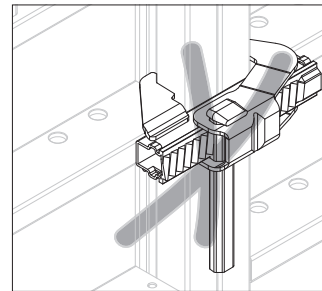

Fig. A4.02b



If the wedge head rests on the sliding part, there is no clamping effect! (Fig. A4.02b)

Then: release wedge, re-position the sliding part and secure once again with the hammer.

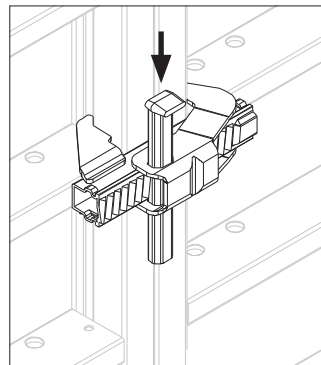

Fig. A4.02a

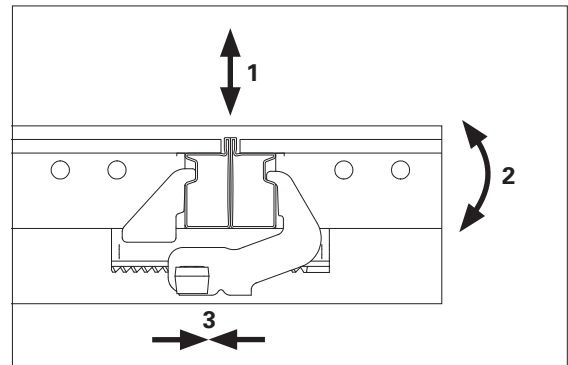

Fig. A4.03



When securing the wedge, the following effects occur due to the angle of the frame profile:

- 1 Panels are flush.
- 2 Panels are aligned.
- 3 Panels are tightly connected. (Fig. A4.03)

Arrangement of the Alignment Couplers

Height 270 cm, see Fig. A4.04a.

Height 330 cm, see Fig. A4.04b.

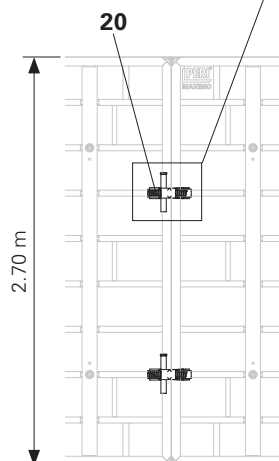

Fig. A4.04a

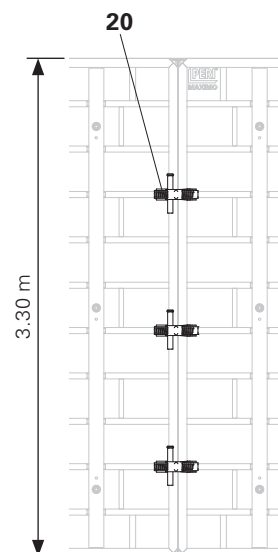

Fig. A4.04b

Compensation Walers

MAR 85 and MAR 170

(Fig. A4.05)

The Compensation Walers MAR have a triple function as panel connections: to brace, align, and transferring forces.

Areas of use:

- length compensation: see B5,
- corners with double Wall Thickness Compensator WDA,
- extensions at great heights: see B7,
- offset struts, see Fig. A4.06a.

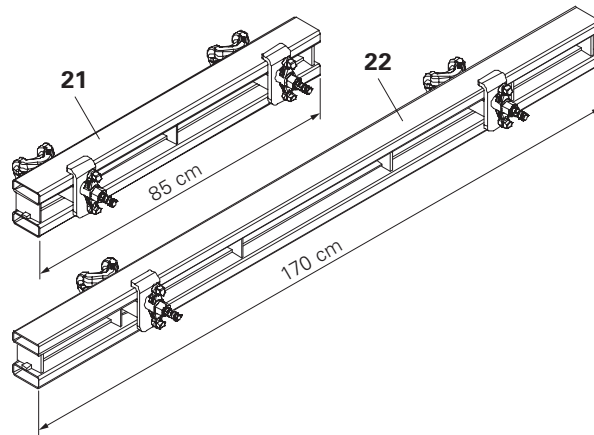

Fig. A4.05

Pos.	Component – alternative	Item no.
21	Compensation Waler MAR 85-3	124941
22	Compensation Waler MAR 170-3	124942

Assembly

1. Insert hook in the connecting holes of the panel.
 2. Tighten nut.
- (Fig. A4.06)

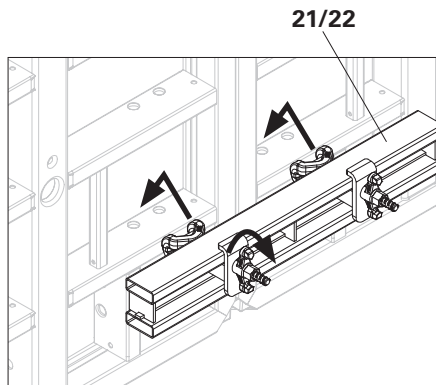

Fig. A4.06

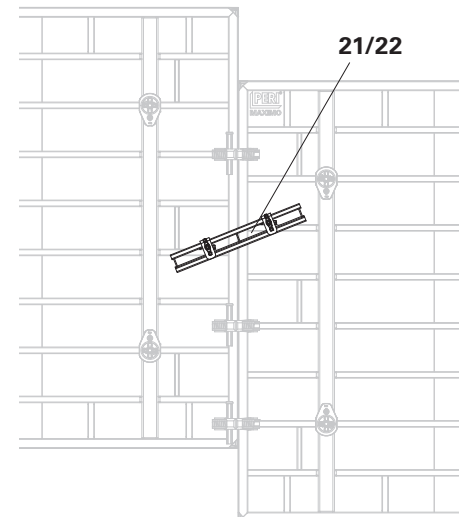

Fig. A4.06a



With T-junctions on the straight wall, install Compensation Waler MAR 170 (22) centrally to the outgoing wall. Attach the double hook of the compensation waler to the middle holes. (Fig. A4.07) 90° T-junctions, see Section D3.

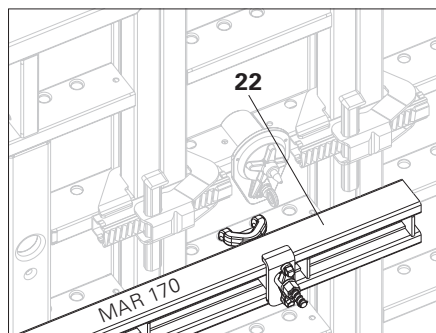

Fig. A4.07

Tie System MX 18

Perm. tensile force of the tie rods:
130 kN.

MX 18 Ties 15 – 25

Item no. 123901
 Ties for wall thicknesses of
 15, 17.5, 20, 22, 24 and 25 cm (30).
 (Fig. A5.01)

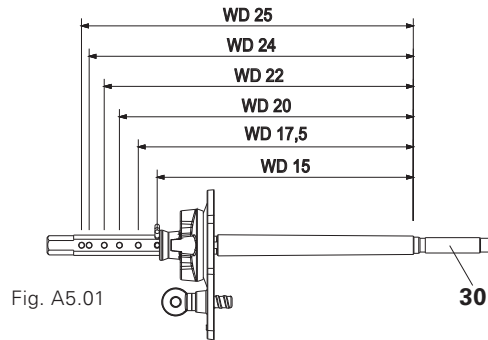

MX 18 Ties 20 – 30

Item no. 123902
 Ties for wall thicknesses of
 20, 22, 24, 25 and 30 cm (31).
 (Fig. A5.02)

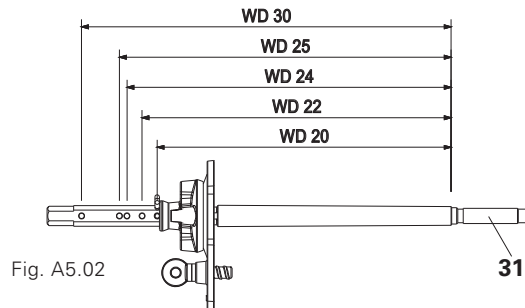

MX 18 Ties 30 – 40

Item no. 123903
 Ties for wall thicknesses of
 30, 35, 36 and 40 cm (32).
 (Fig. A5.03)

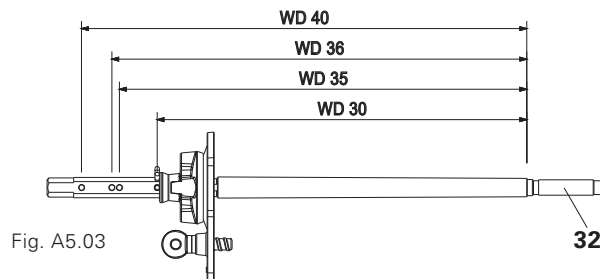

MX 18 Ties 40 – 50

Item no. 123904
 Ties for wall thicknesses of
 40, 45 and 50 cm (33).
 (Fig. A5.04)

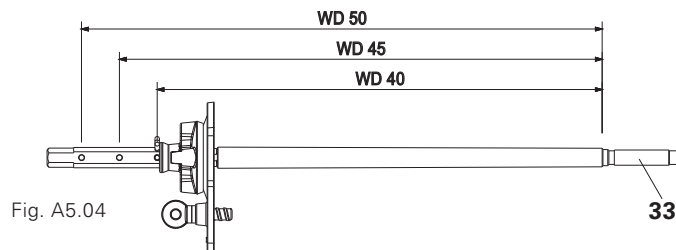

MX 18 Ties 50 - 60

Item no. 123905
 Ties for wall thicknesses of
 50, 55 and 60 cm (34).
 (Fig. A5.05)

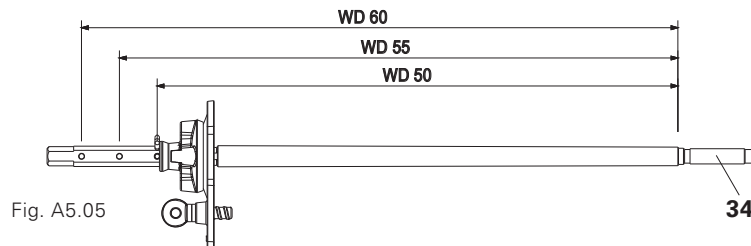

Mount ties

Pos.	Components	Item no.
10	MAXIMO MX 18 Panel	acc. to size
31	MX 18 Tie	acc. to size*
35	Swivel Nut MX 18	123900
40	TRH Tie Rod Spanner	108719
57	Scaffold ratchet	796061 alternative: to Pos. 40

* size of tie is determined by wall thickness.

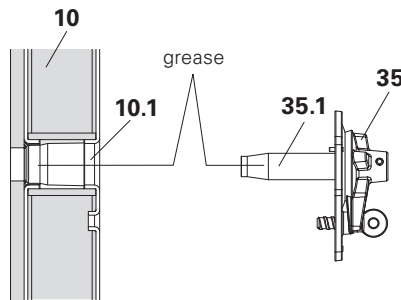

Fig. A5.04a

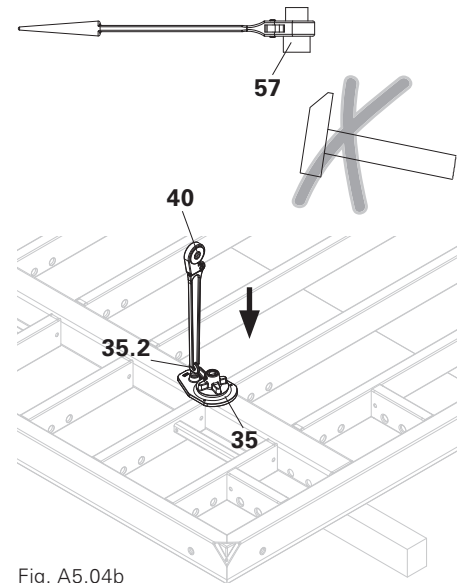

Fig. A5.04b

Prepare primary formwork for initial use

- Grease tie holes (10.1) in panel (10) and sleeve (35.1) of the Swivel Nut MX 18 (35). (Fig. A5.04a)
- Fix Swivel Nut MX 18 to the primary formwork by means of the ring spanner (35.2). Use Tie Rod Spanner (40) or scaffold ratchet (57)! (Fig. A5.04b)

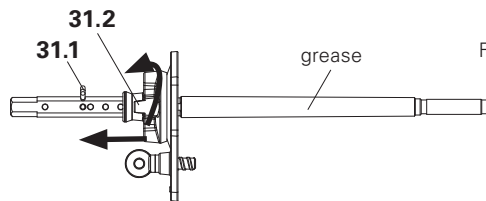

Fig. A5.05

Prepare ties

- Mark out wall thickness with cotter pin (31.1).
- Turn nut (31.2) to the cotter pin. (Fig. A5.05)
- Grease MX 18 Tie.

Closing formwork

Important: pay attention to the order!

- Push MX 18 Tie (31) through the tie hole of the formwork and screw into Swivel Nut MX 18 (35).
- Turn the plate with the ring spanner so that it can be fixed in position.
- Screw in MX 18 Tie with the Tie Rod Spanner as far as possible. → The nut (31.2) is lying flush on the formwork.
- Slightly tighten the ring bolt (31.3) by means of the Tie Rod Spanner or scaffold ratchet (57).

(Fig. A5.06)

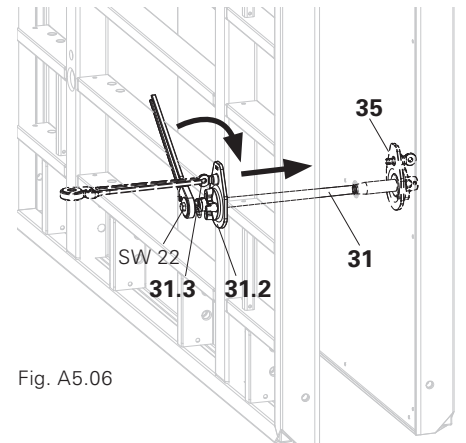

Fig. A5.06

Release ties.

Important: pay attention to the order!

- Release ring bolt (31.3) using the Tie Rod Spanner or scaffold ratchet (57).
- Screw out MX 18 Tie (31) with the Tie Rod Spanner.

(Fig. A5.07)



Before moving each time, tighten Swivel Nut MX 18 with the ring bolt.



- Only use a Tie Rod Spanner (40) or scaffold ratchet (57).
- Do not attach any extensions – results in tie damage.
- Do not use any ties which are damaged.

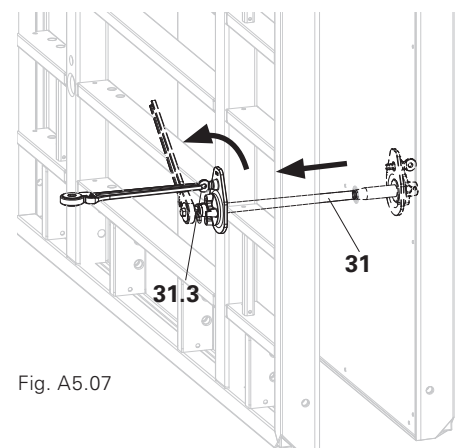

Fig. A5.07

Closures

Plug MXM 18, D = 26 mm

Item no. 125099

Closing of tie holes in the formlining, e.g. Multi-Purpose Panel MXM 18, height x 60, Inside Corner MXI 18, height x 50/20 and tie hole. (Fig. A5.08 + A5.08a)



Fig. A5.08

Example:
Inside Corner MXI 18,
height x 50/20

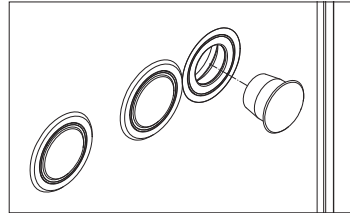

Fig. A5.08a

Plug MX Ø 24 – 28 mm

Item no. 125300

Visually-attractive closure of the tie point in the concrete. (Fig. A5.09)



Fig. A5.09

Miscellaneous

Tie Rod Wrench (41) for one-man tie point operations from one side of the formwork. (Fig. A5.10)

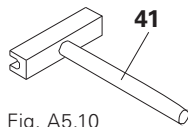

Fig. A5.10

Alternative tie system Tie System DW

DW 20

For high formwork pressure.

Permissible load of the tie rod according to DIN 18216: 150 kN.

(Fig. A5.11)

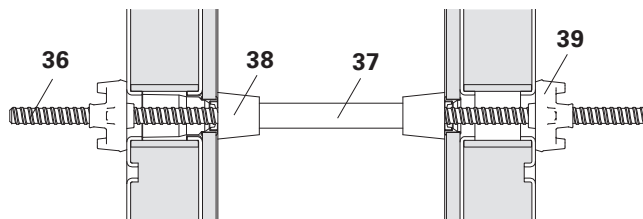

Fig. A5.11

Pos.	Components	Qty
36	Tie Rod DW 20	1x
37	Spacer Tube DR 28	1x
38	DK Sealing Cone	2x
39	Swivel Nut DW 20	2x

Inclined Ties



- The conical tie hole allows inclined anchoring of up to 4° on all sides. (Fig. A5.11 + A5.15)
- Inclined anchoring is possible with both vertically and horizontally-positioned panels.
- Secure panel against lifting!

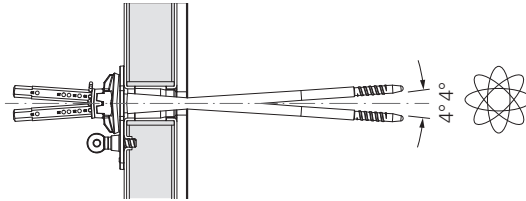

Fig. A5.11

For the MX 18 Tie and Tie Rod DW 20, there are further areas of application:

MX 18 Tie

Inclined on one side: max. 4°. (Fig. A5.12)

Inclined on both sides: max. 2 x 4°. (Fig. A5.13)

Height offset: max. 1 cm per 10 cm wall thickness. (Fig. A5.14)

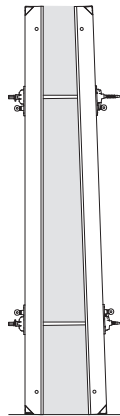

Fig. A5.12

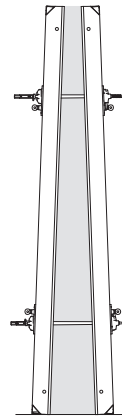

Fig. A5.13

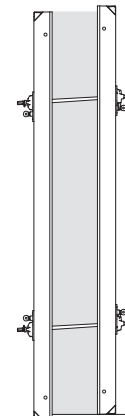

Fig. A5.14

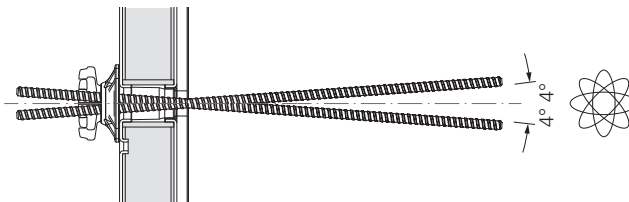

Fig. A5.15

Tie Rod DW 20

Inclined on one side: max. 4°. (Fig. A5.16)

Inclined on both sides: max. 2 x 4°. (Fig. A5.17)

Height offset: max. 1 cm per 10 cm wall thickness. (Fig. A5.18)

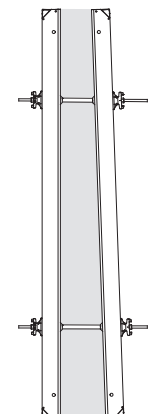

Fig. A5.16

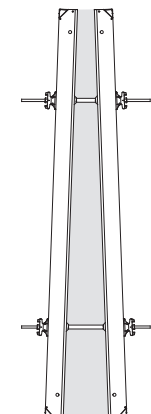

Fig. A5.17

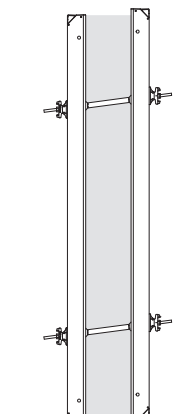

Fig. A5.18

Closing Tie Points

Sealing against pressing water and non-pressing water for waterproof tie points as well as fire and soundproof tie points.

There are three types of plugs:

1. Stopper MX 18-50 MF LS (90)

Against non-pressing water and sound.

2. Stopper MX 18-50 OF LS (91)

Against non-pressing water, fire and sound.

3. Stopper MX 18-75 MF-S (92)

Stopper MX 18-75 MF-L (93)

Against pressing water, fire and sound.

4. Stopper MX 18-75 OF-S (94)

Stopper MX 18-75 OF-L (95)

Against pressing water, fire and sound.

(Fig. A5.19)

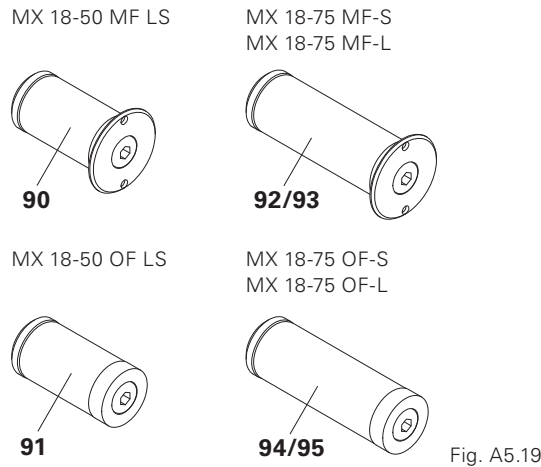

Stoppers are **not** suitable for use in aggressive water or similar, e.g. sewage treatment plants!

Possible uses of the Stopper MX 18 for tie points with special requirements

Pos.	Stopper	Item no.	Sealing against water	Fire-resistance	Soundproofing
90	MX 18-50 MF LS	127589	Sealing against non-pressing water. Plugs fitted on the water side.	Walls with Fire Resistance F90. Test report available. Plugs on both sides.	Walls with sound protection function. Test report available. Plugs on one side or both sides.
91	MX 18-50 OF LS	127590	Sealing against non-pressing water. Plugs fitted on the water side.	Walls with Fire Resistance F90. Test report available. Plugs on both sides.	Walls with sound protection function. Test report available. Plugs on one side or both sides.
92 93	MX 18-75 MF-S MX 18-75 MF-L	127430 127488	For waterproof components, Test report available. Plug on both sides.	Walls with Fire Resistance F90. Test report available. Plugs on both sides.	Walls with sound protection function. Test report available. Plugs on one side or both sides.
94 95	MX 18-75 OF-S MX 18-75 OF-L	127432 127490	For waterproof components, Test report available. Plug on both sides.	Walls with Fire Resistance F90. Test report available. Plugs on both sides.	Walls with sound protection function. Test report available. Plugs on one side or both sides.

Stopper MX 18-50

Stoppers MX 18-50 MF LS (90) and MX 18-50 OF LS (91) can be installed in tie holes with small as well as large diameters. (Fig. A5.20)

Stopper MX 18-75

Always install Stopper MX 18-75 MF-S (red) (92) in tie holes with small diameters and Stopper MX 18-75 MF-L (yellow) (93) in tie holes with large diameters. (Fig. A5.21)

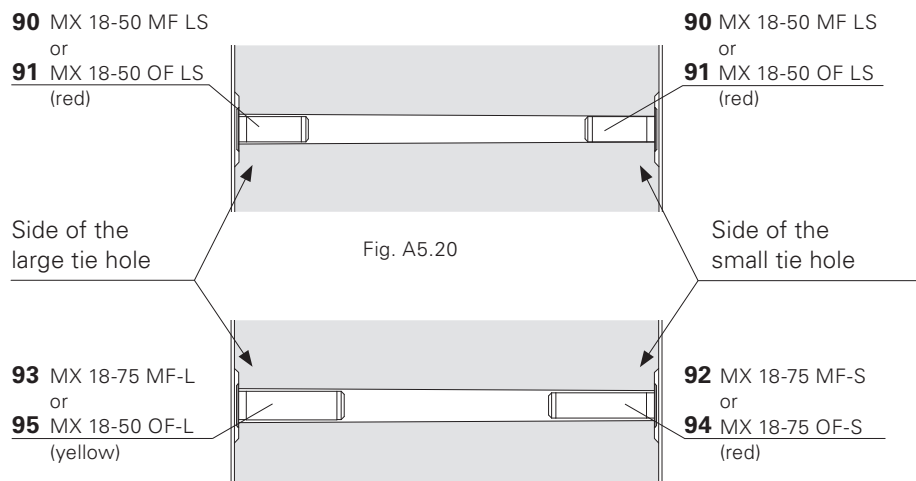

Fig. A5.21

Standard application

		Formwork height h [m] System 1						Formwork height h [m] System 2			
		3.00	4.00	5.00	6.00	7.00	8.00	9.00	10.00	11.00	12.00
Permissible width of influence [m]	EB_{ref}	4.41	3.42	2.69	2.22	2.02	1.74	2.45	2.07	1.80	1.52
Actual push-pull prop load [kN]	F_{RS1}	11.5	11.5	11.5	11.5	11.5	11.5	11.5	11.0	11.5	11.5
	F_{RS2}							10.9	11.5	11.2	10.5
Actual kicker load [kN]	F_{AV}	2.7	2.9	2.8	2.7	3.2	3.5	4.2	3.6	3.4	3.1
Base plate Resulting force [kN]	①	13.7	13.7	13.5	13.4	13.7	13.9	11.5	11.0	11.5	11.5
	②							14.2	14.3	13.7	12.8
Base plate Resulting angle of attack [°]	①	52.4	51.1	51.1	51.1	49.4	48.2	60.0	60.0	60.0	60.0
	②							47.9	49.8	49.9	49.8
Lifting force V_{Wind} [kN/m]		2.5	3.1	3.9	4.7	5.1	5.9	8.4	9.9	11.4	13.0
x = Distance of base plate from rear edge of formwork [m]	x_1	1.2	1.6	2.0	2.4	3.0	3.6	4.2	4.7	5.1	5.5
	x_2							2.6	2.6	2.8	3.0
y = Top connection point from top of formwork [m]	y_1	1.0	1.2	1.5	1.8	1.8	1.8	1.5	1.8	2.1	2.4
	y_2							4.5	5.5	6.2	6.9
$q(z=h) = q_h$ [kN/m ²]		0.59	0.59	0.59	0.59	0.59	0.61	0.64	0.66	0.69	0.71

Load assumptions:

- Wind loads according to DIN 1055-4:2005-03 $w = q(z) \times c_p \times \kappa$ [kN/m²]
- Inland, Wind Load Zone 2
- Assumed aerodynamic coefficient $c_p = 1.8$ (see graphic, below)
- Formwork in vertical position on ground
- Service life factor $\kappa = 0.6$
- $q(z) =$ peak velocity pressure
- Inclination of the Push-Pull Prop to the horizontal 60°
- Values are characteristic values

Note:

Anti-lift off protection is to be provided if the lifting force $F_A = 1.5 \times V_{Wind} - 0.9 \times G \times h > 0$
 $G =$ surface area weight of the formwork including platforms.

In the end area L_E , the following c_p -values or wind loads are assumed:

$L/h \leq 3$: $c_{p, End} = 2.3^*$
 $L/h = 5$: $c_{p, End} = 2.9^*$
 $L/h \geq 10$: $c_{p, End} = 3.4^*$
 $L_E =$ length of end area ($0.3 \times h$)
 $h =$ formwork height
 $L =$ formwork length

*intermediate values are interpolated

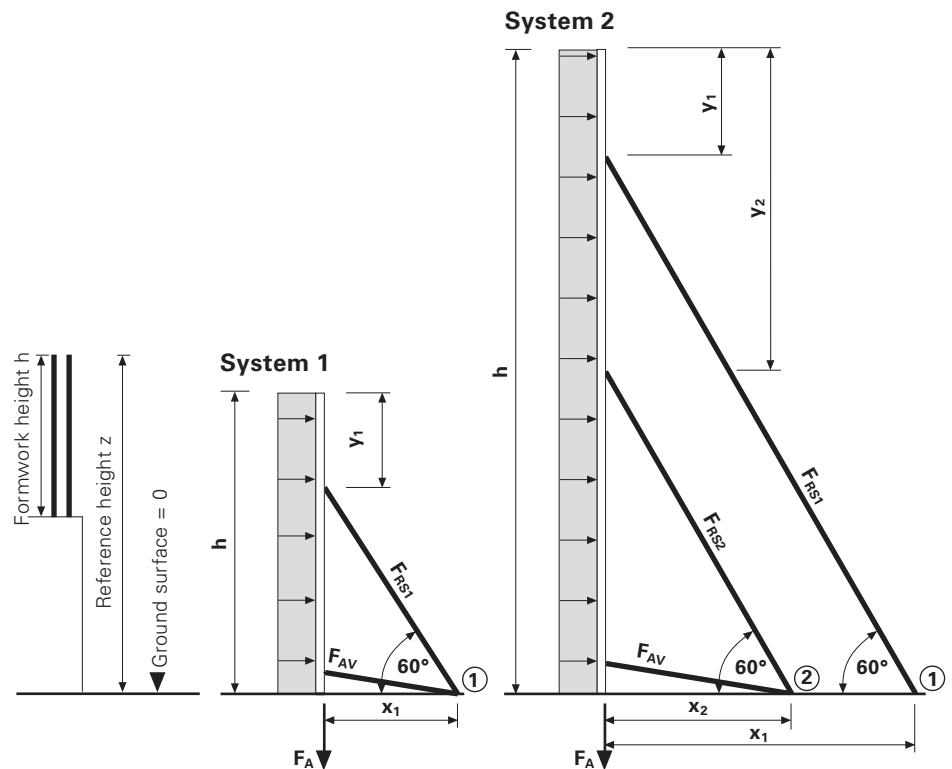
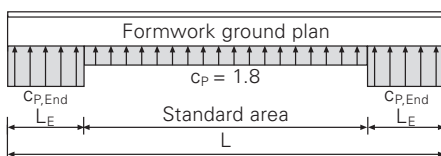

Brace Connector

Item no. 023660 (Fig. A6.01)

Push-pull props and kickers are attached to the panel with the Brace Connector. Connecting to both horizontal and vertical panel struts is possible. (Fig. A6.02 + A6.03)

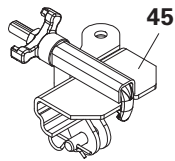

Fig. A6.01

Assembly

1. Attach the Brace Connector (45) to the panel strut so that the Hook Tie is securely fixed in a connecting hole.
2. Tighten Brace Connector by means of a Triple Wingnut.

Horizontal section (Fig. A6.02a)

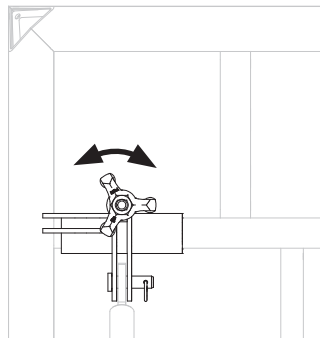

Fig. A6.02

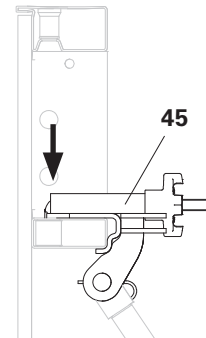

Fig. A6.02a

Vertical section (Fig. A6.03a)

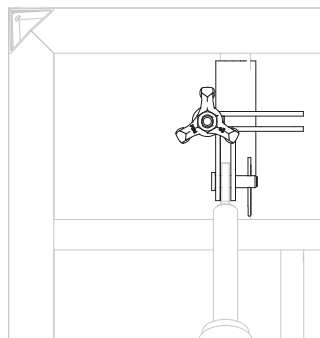

Fig. A6.03

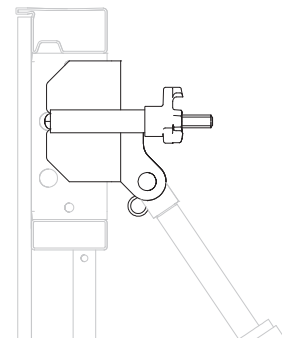

Fig. A6.03a

Push-Pull Props and Kickers

Assembly

1. Fix Push-Pull Prop or Kicker (46) to the connection lugs by means of pins and cotter pins. (Fig. A6.04 + A6.04a)
2. Fix Base Plate (47), e.g. with PERI Anchor Bolt 14/20x130. (Fig. A6.04b)



When using the PERI Anchor Bolt 14/20x130, take data sheet into consideration!

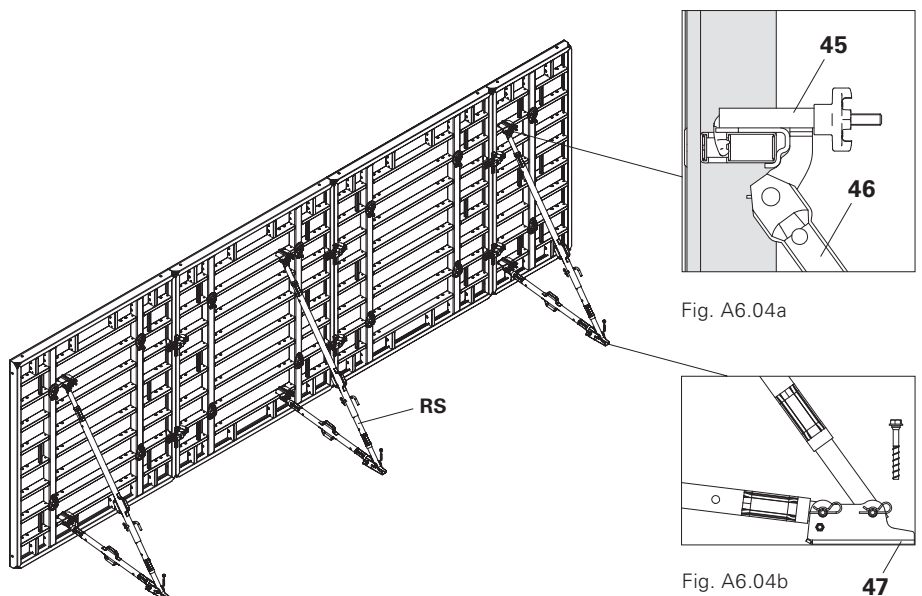

Fig. A6.04

Fig. A6.04a

Fig. A6.04b

Concreting Platform 120/270

Pos.	Component	Item no.
60	Concreting Platform 120/270	022950

Perm. load: 150 kg/m²

Load Class 2 according to DIN EN 12811-1.

Assembly

1. Fold up guardrails (60.1) and secure with bolts (60.2). (Fig. A7.01)
2. Fold up Suspension Beam (60.3) until it engages. (Fig. A7.02)



The Sliding Sleeve (60.4) must be in position above. (Fig. A7.02)

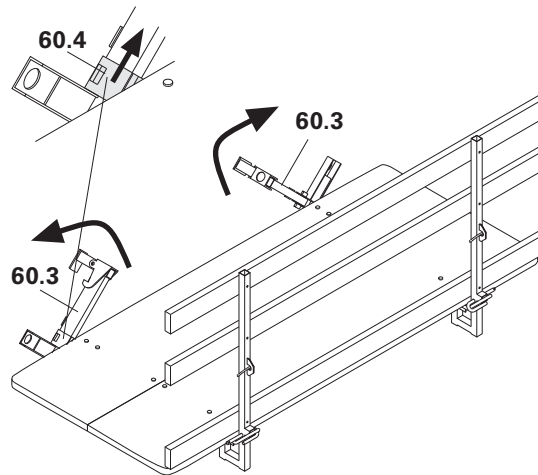
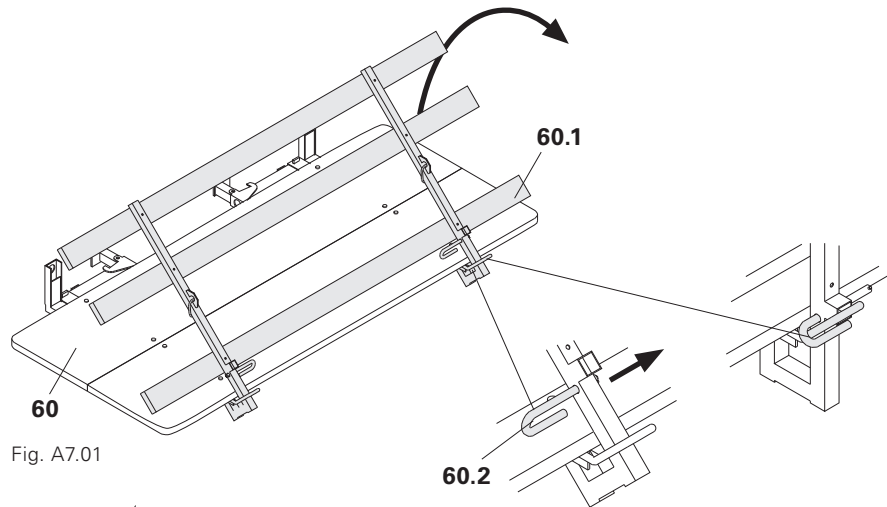

3. Attach 4-sling lifting gear to the concreting platform. (Fig. A7.03)



The suspension points (load-bearing points) are coloured yellow. Concreting Platform 120/270.

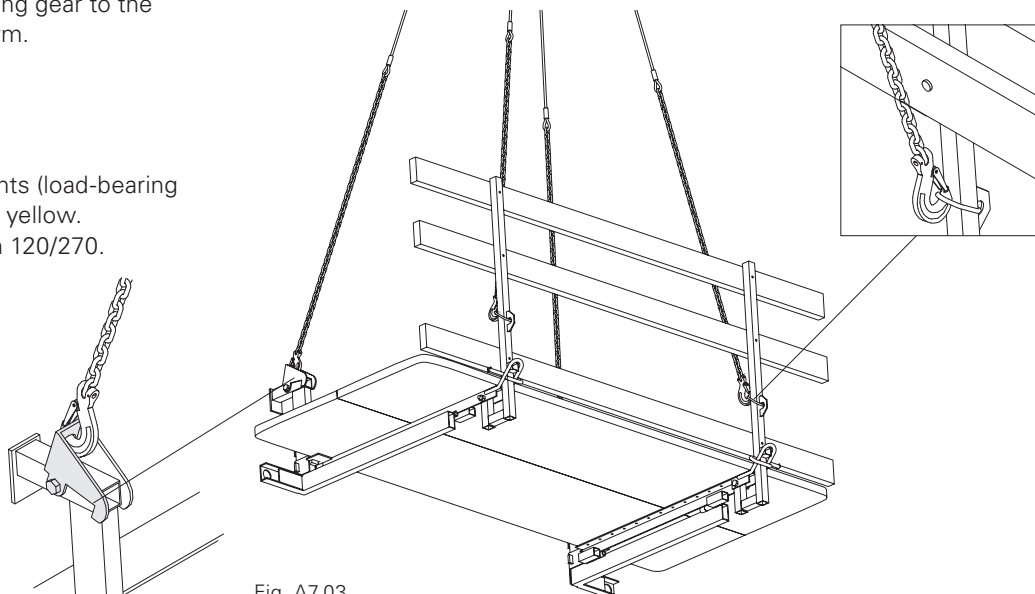

4. Attach concreting platform to the top edge of the formwork by means of the Suspension Beam. Guide from below using guide rope. (Fig. A7.04)

Example: height 2.70 m

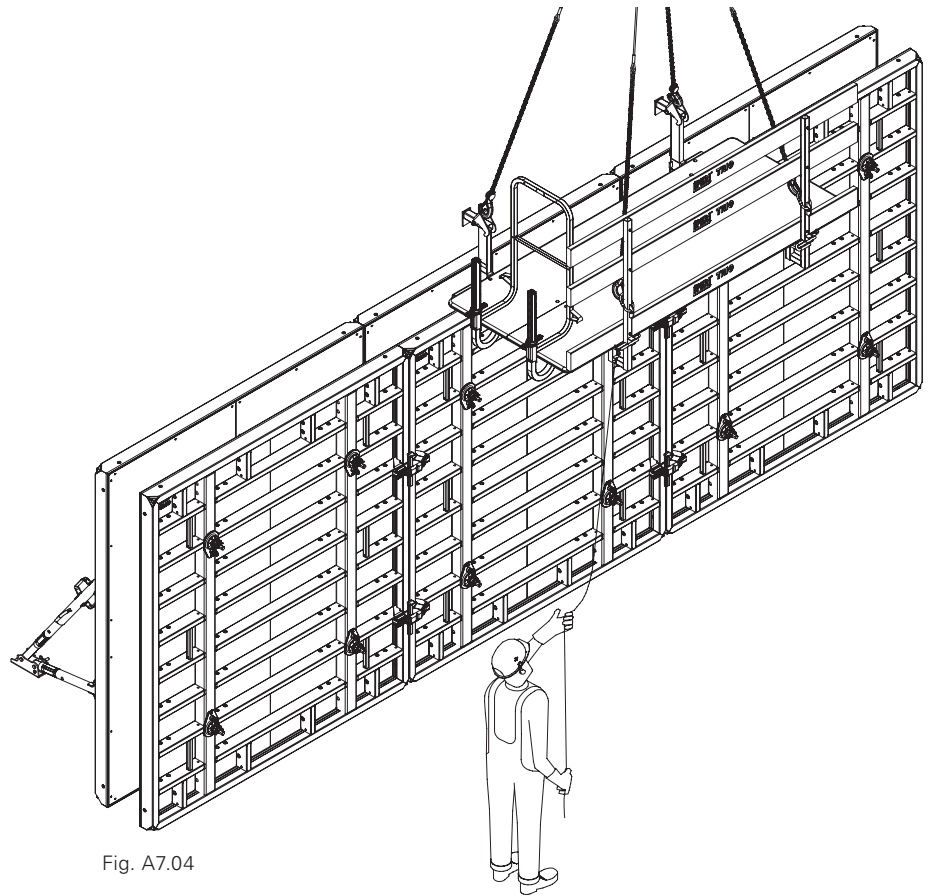

Fig. A7.04

5. Remove 4-sling lifting gear.
 → The Retaining Claw (60.5) grips the frame profile and secures.
 (Fig. A7.05)



Visual check is carried out on the Retaining Claw.

6. Attach side protection, e.g. End Guardrail Frame 55.



The concreting platform must be dismantled during temporary storage of the element.

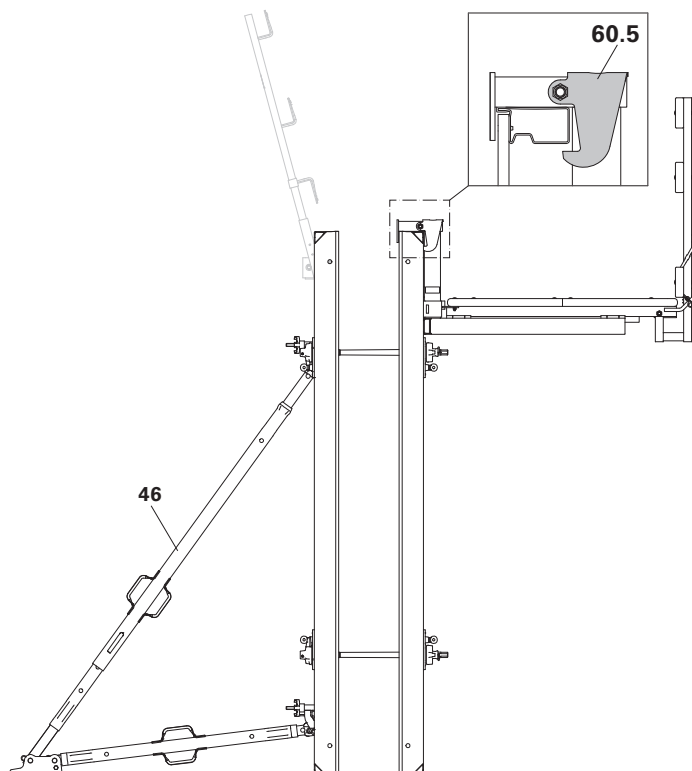

Fig. A7.05

Place guardrail in an inclined position



Place guardrail in an inclined position before moving with the crane!

1. Remove securing pin and cotter pin (60.2).

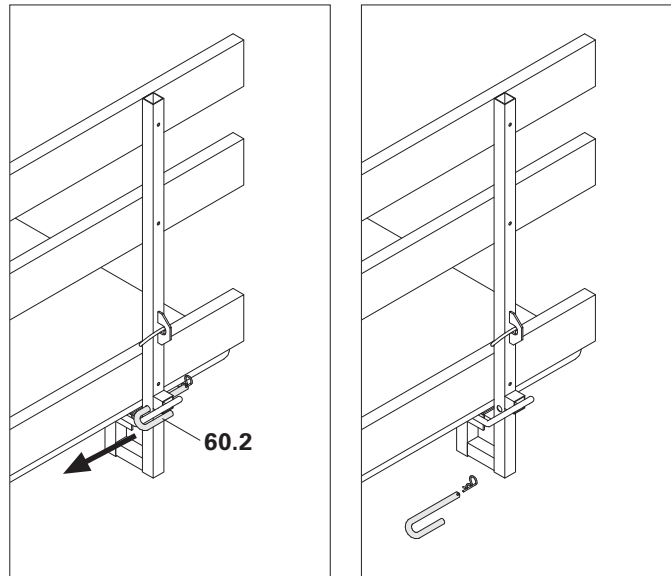

2. Guardrail frame is placed in an inclined position to the rear, max. 15°.
3. Install securing pins and secure with cotter pins.
→ Guardrail frame is placed in an inclined position.

(Fig. A7.06)

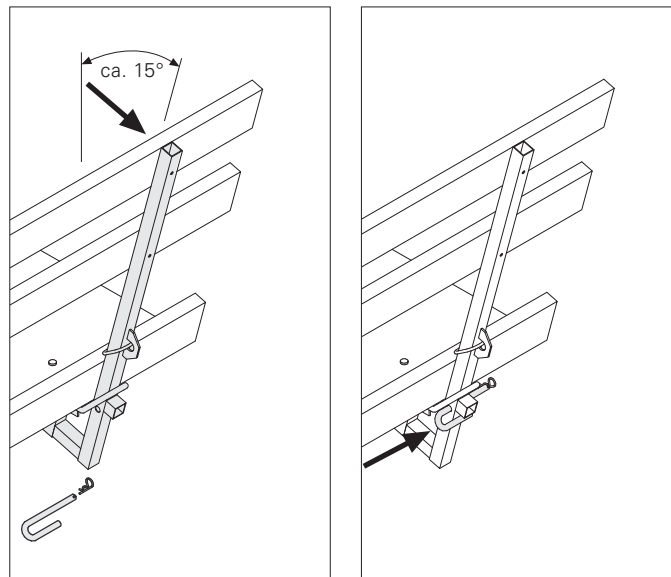

Fig. A7.06

Scaffold Bracket TRG TRG 80 or TRG 120

Pos.	Component	Item no.
63	Scaffold Bracket TRG 80	023670
64	Scaffold Bracket TRG 120	023680
65	End Guardrail Frame FTF	104018

A concreting scaffold is erected on the formwork by means of the scaffold brackets.

(Fig. A7.07)

Example: height 2.70 m.

Technical data

- Perm. load: 150 kg/m² Load Class 2 according to DIN EN 12811-1.
- Max. width of influence 1.35 m.



- **Secure planking!**
- **Decking components and guardrails must be securely mounted in position at all times.**



With extended formwork units, the work scaffold is mounted as part of the pre-assembly process.

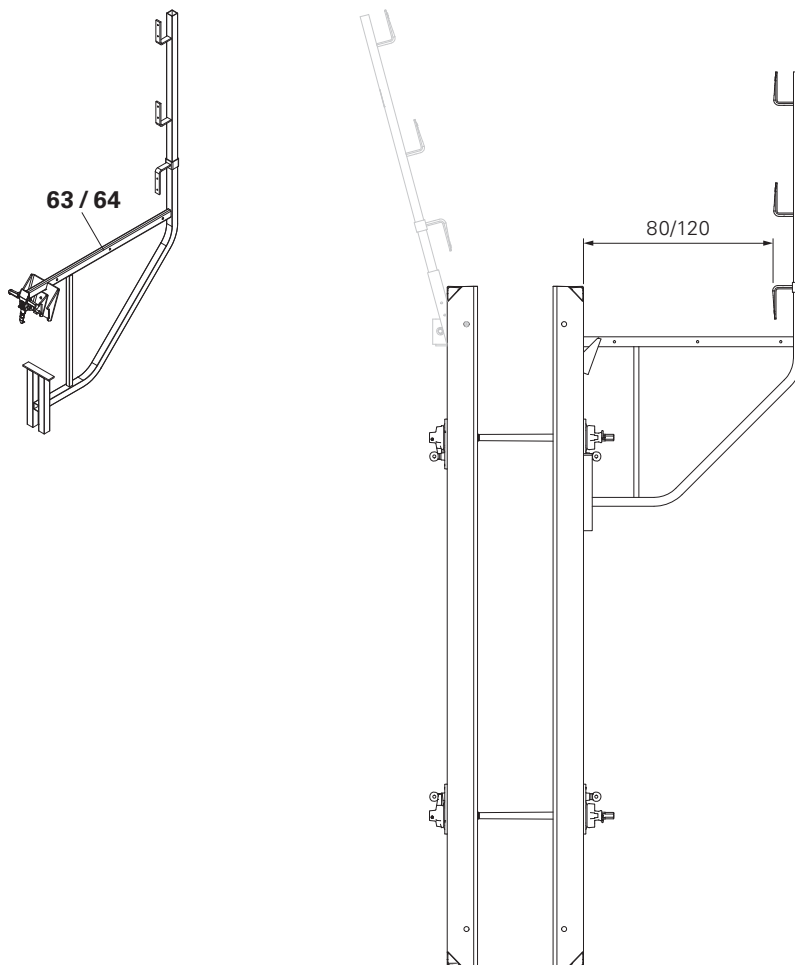

Fig. A7.07

Assembly of the Scaffold Bracket TRG

1. Hook in Scaffold Brackets (63 / 64) into the connecting holes of the panels. It is possible to use both the horizontal and vertical panel struts. (Fig. A7.08)



Visual check of the mounting equipment.

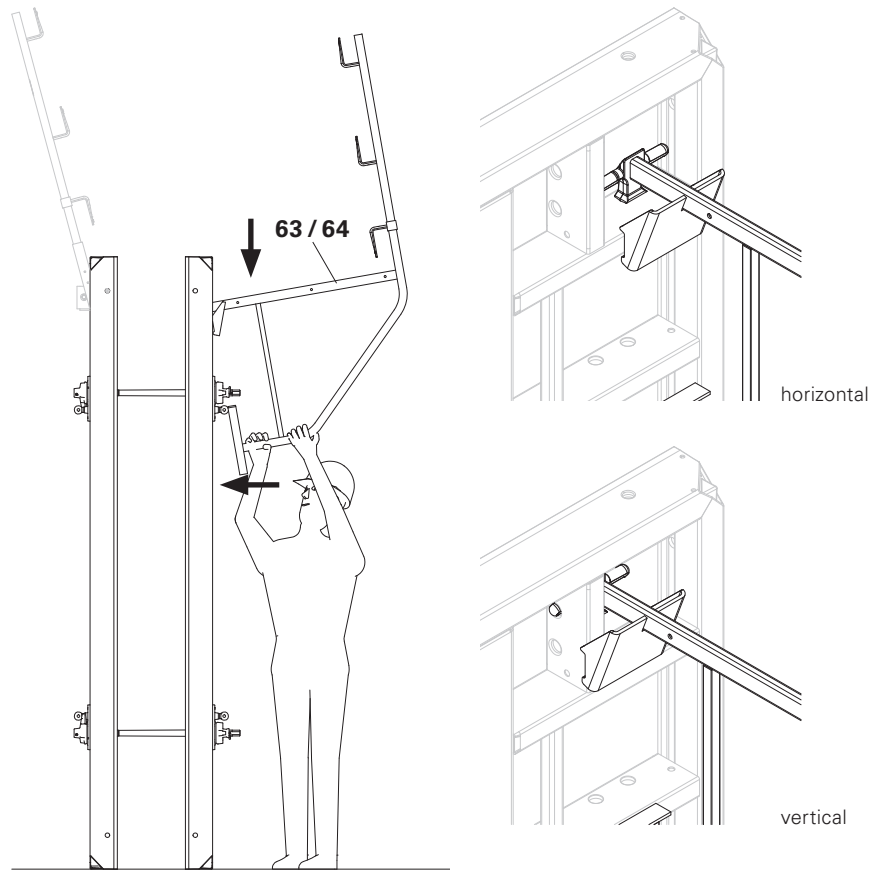

Fig. A7.08

2. Install planking from below over the complete width of the brackets and secure in position.
3. Install guardrails and secure with nails.
4. Attach side protection, e.g. End Guardrail Frame 55 (65). (Fig. A7.09)

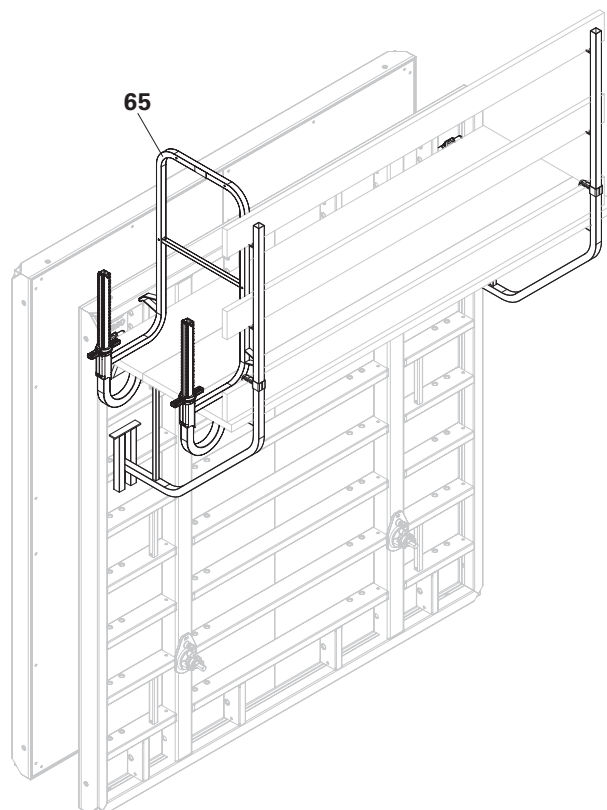

Fig. A7.09

Guardrails

Pos.	Component	Item no.
66	Guardrail Post Holder	101592
67	Guardrail Post HSGP-2	116292

Mount guardrails on the side opposite to the concreting scaffold. (Fig. A7.10)
 Assembly is carried out horizontally.
 In cases of vertical assembly from a safe position, use a mobile scaffold, for example.

Technical data

Max. width of influence 1.80 m.



Secure boards with nails!



- Assembly is only possible on vertical struts!
- With extended formwork units, the guardrails are mounted as part of the pre-assembly process.

Assembly

1. Hook in Guardrail Post Holder (66) into the connecting holes of the panels.
2. Secure with cotter pins.
3. Insert Guardrail Post HSGP-2 (67).
4. Mount Side Mesh Barrier PMB or install guardrail boards and then secure with nails.
 → Opposing guardrails
 (Fig. A7.11)

When erecting, make sure that the guardrails are not damaged by the lifting gear.

Dismantling

Do not lay the formwork unit on the Guardrail Post Holder.

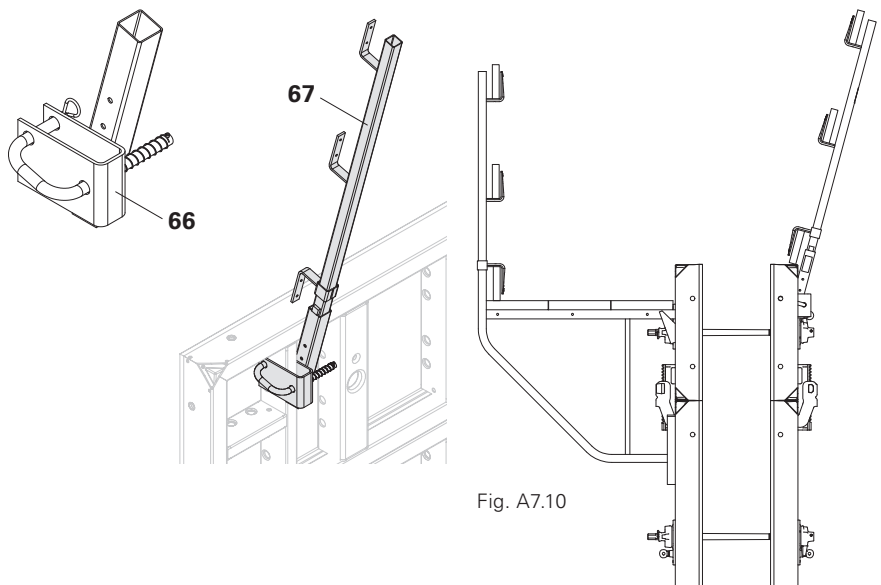

Fig. A7.10

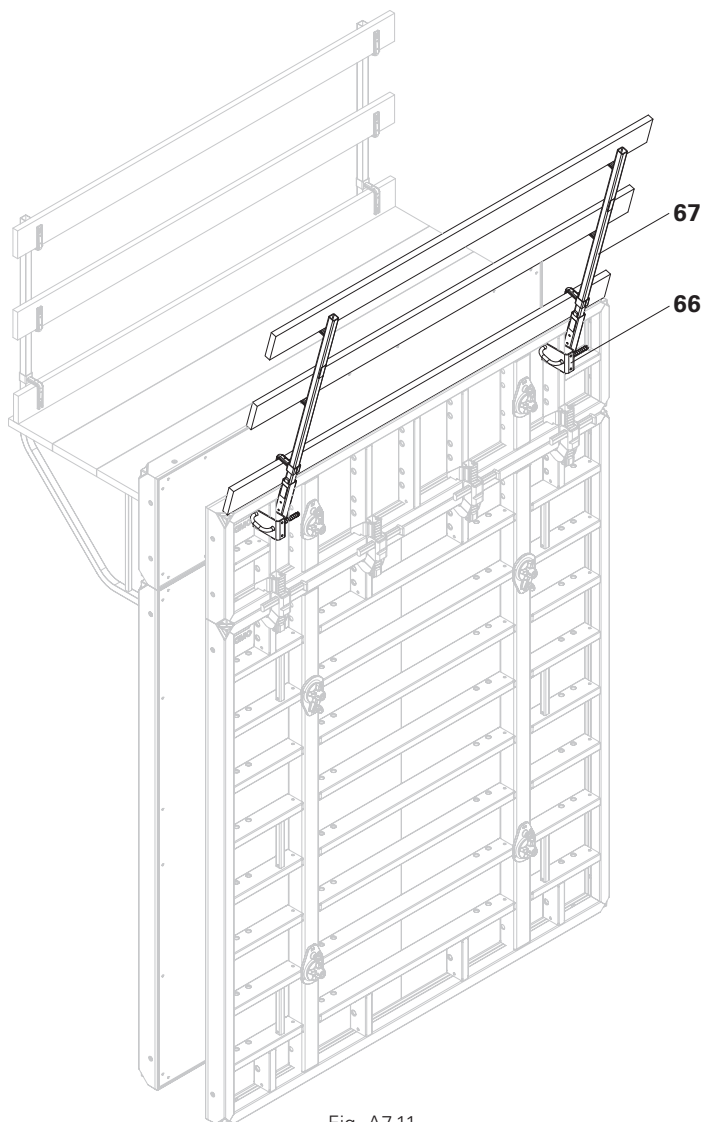

Fig. A7.11

Horizontal downward extension panels up to 2.10 m high

MX 18...30 (Fig. A8.01)

Note: Install 4 BFD Alignment Couplers as panel connections with Downward Extension Panel MX 18...30.
(Fig. A8.01)

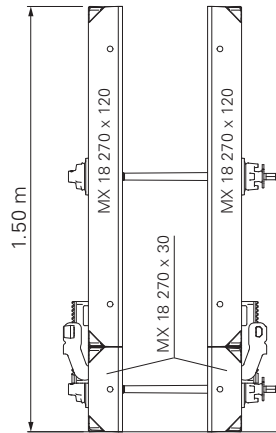

Fig. A8.01

MX 18...60 (Fig. A8.02)

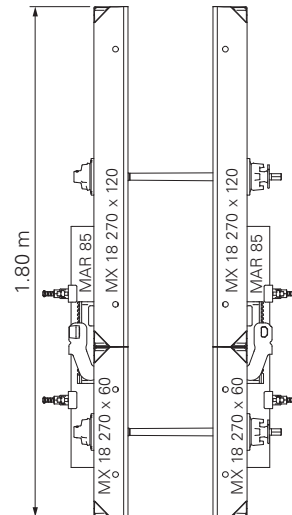
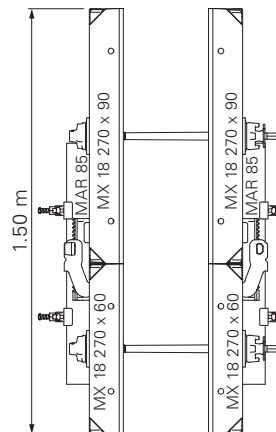

Fig. A8.02

MX 18...90 (Fig. A8.03)

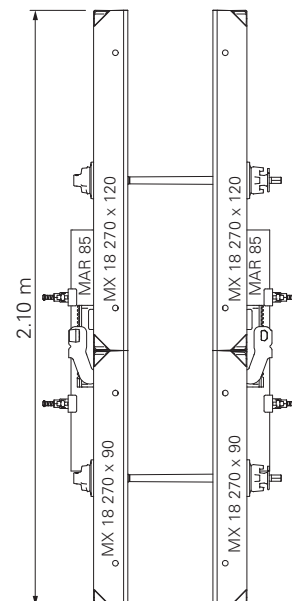
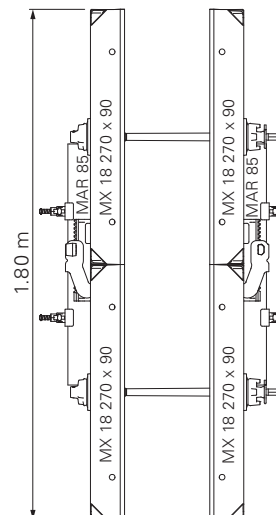

Fig. A8.03

Arrangement of the Alignment Coupler
BFD and Waler MAR 85.
Example: MX 18...60 und MX 18...90.
(Fig. A8.04)

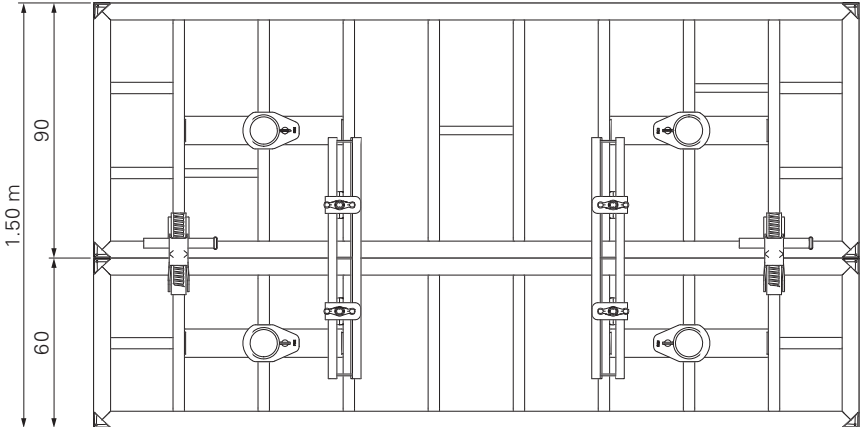

Fig. A8.04

Tension and Compression Brace MX15-40 and MX15-100

For heights ≤ 1.20 m, e.g. parapets.

Adjust Tension and Compression Brace to:

Setting dimension = wall thickness + 5 mm.



Perm. tension and compression force = 9 kN.

Depending on the wall thickness, the following table shows which Tension and Compression Brace and anchor fastenings can be used.

Wall thickness	Tension and Compression Brace		Tie MX 18	Tie Rod DW 20*
	MX 15-40	MX 15-100		
≤ 40 cm	x	x	x	x
≤ 60 cm	–	x	x	x
≤ 100 cm	–	x	–	x

* Swivel Nut DW 20 (Item no. 115571) is used with the Tie Rod DW 20

Preparation

- Adjust Mounting Shoe (70.2) of the Tension and Compression Brace to required setting dimension:
 - Remove cotter pin from bolt.
 - Pull bolt out of Spacer Rack (70.3).
 - Slide holes of the Mounting Shoe (70.2) and Spacer Rack (70.3) on top of each other according to the setting dimension.
 - Insert bolts through holes.
 - Insert cotter pin into the hole of the bolt.
- Pivot the securing hook (70.1) of the Tension and Compression Brace upwards. (Fig. A9.01a)
 - Tension and Compression Brace is opened for positioning.

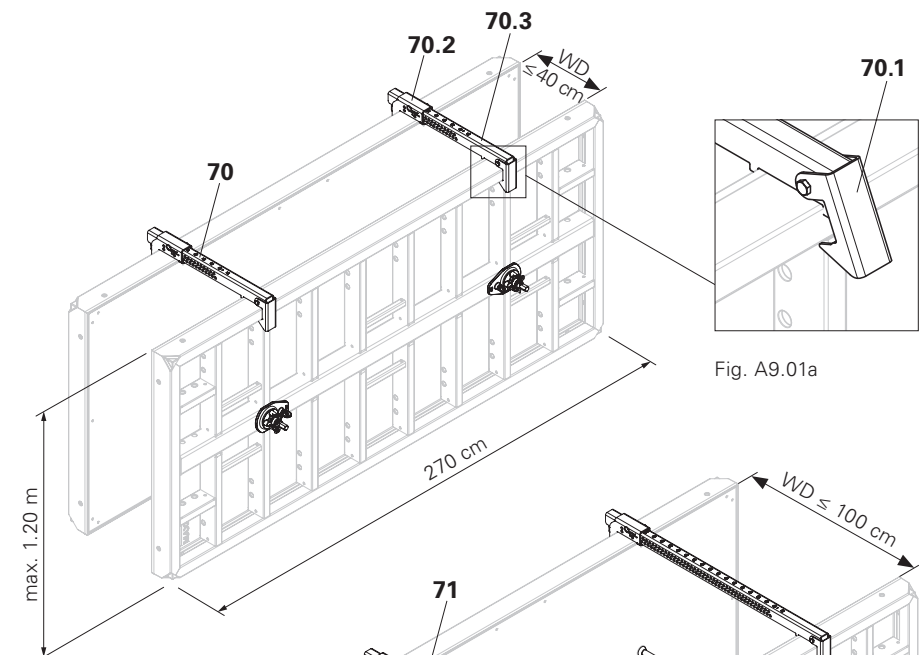

Fig. A9.01

Assembly

- Place Tension and Compression Brace on the panel in the area of the tie point; at the same time, mount the Mounting Shoe (70.2) in the edge profile of the formwork.
- Press the securing hook (70.1) downwards over the edge profile and the panel strut of the formwork.
 - Tension and Compression Brace is locked in position.

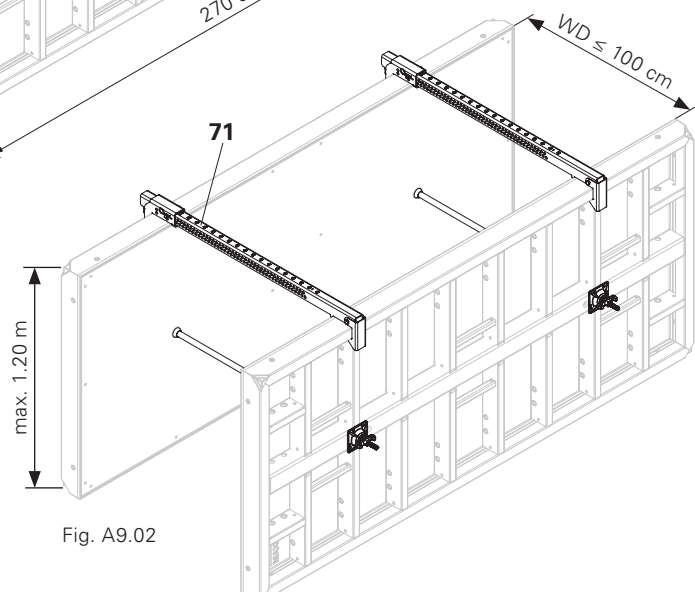

Fig. A9.02

Wall thickness

≤ 40 cm: MX 15-40 – Fig. A9.01

≤ 100 cm: MX 15-100 – Fig. A9.02

Alternative Tie System DW 15

1. Mount Tie System DW 15 (54) and Foundation Tie Clamp TRIO (73). (Fig. A9.03)
2. Close all open tie holes on the formlining side with Plugs (74), Item no. 125099.

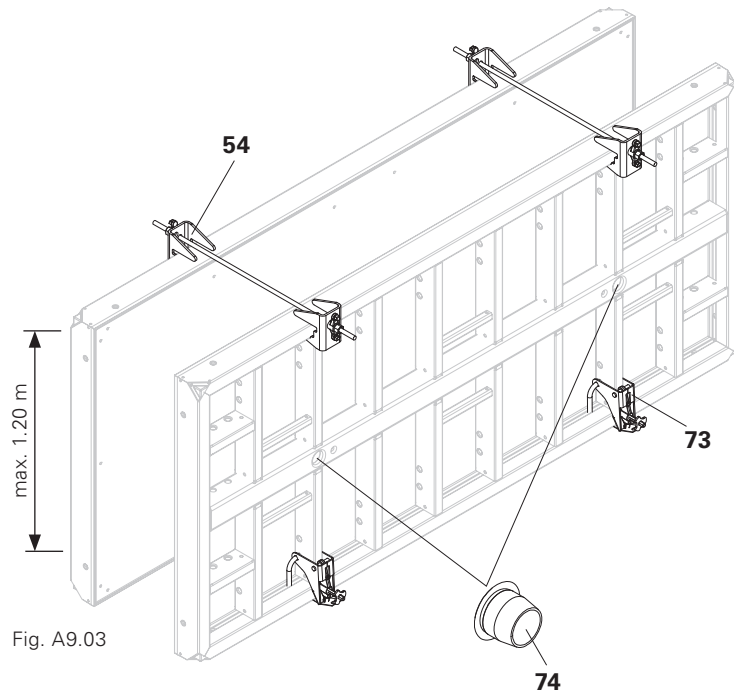

Fig. A9.03

Foundation Strap

Item no. 023800

The Foundation Strap (75) is used for forming individual foundations using the “windmill configuration”. (Fig. A9.04)

H [cm]	perm. W [cm]
60	255
90	200

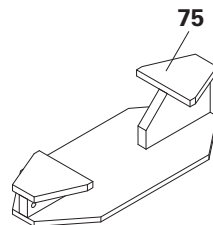

Fig. A9.04

Assembly

1. Secure limiting board (76) on the formlining with nails – at a distance perm. W + 12 cm.
2. Place Foundation Strap at the butt point on the panel.
3. Slide Foundation Strap as far as possible on the offset panel.
4. Upper web rests against the panel.
5. Install Foundation Strap at top and bottom (8x in total). (Fig. A9.05 + A9.05a)

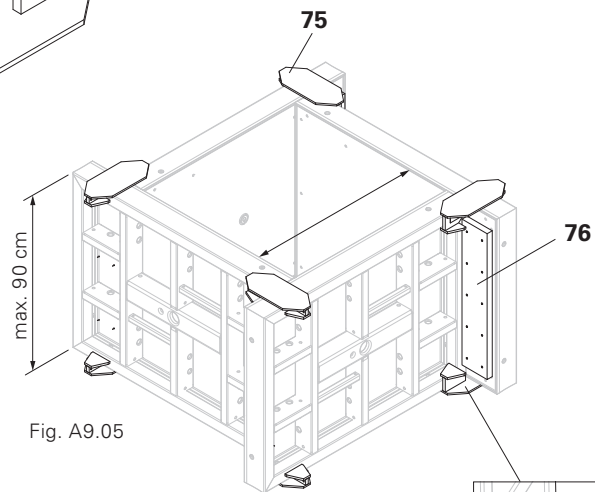

Fig. A9.05

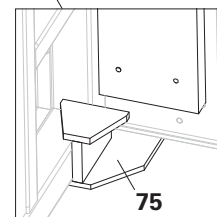

Fig. A9.05a



The Foundation Strap must rest against the panel.

A10 Height Offsets

A11 Wall Connections

Height Offsets

With height offsets – and depending on the offset – the Alignment Couplers BFD are installed alternatively on the panel struts of the right and left panels. (Fig. A10.01)

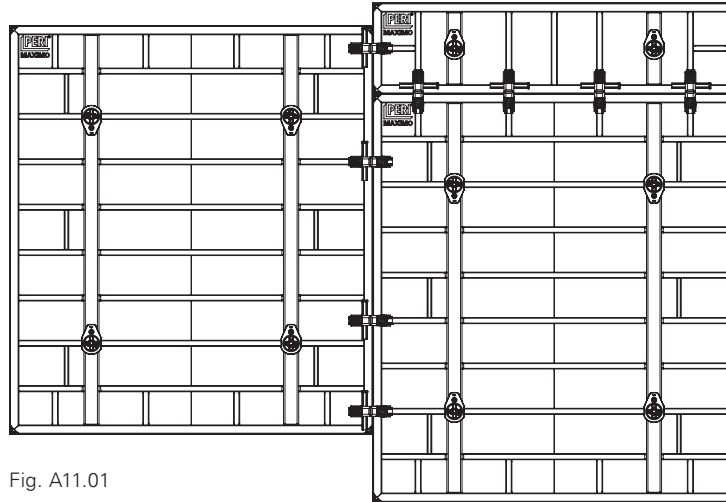

Fig. A11.01

Obtuse Wall Connection

With MX 18 270 x 240 large panel (Fig. A11.01a)

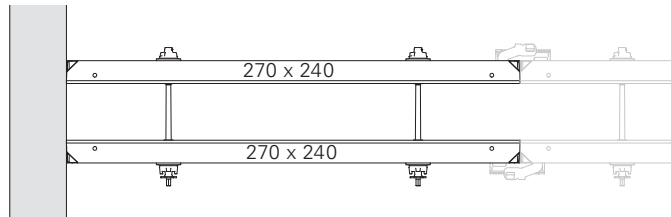

Fig. A11.01a

With Panel MX 18...x ≥ 60 (Fig. A11.01b)

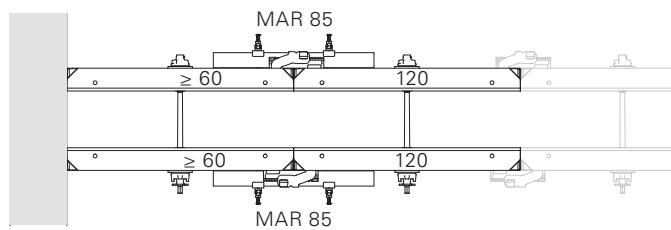

Fig. A11.01b

With Panel MX 18...x ≤ 60 (Fig. A11.01c)

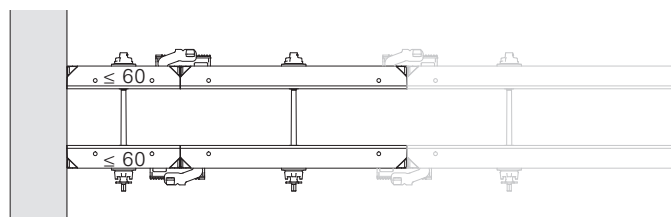

Fig. A11.01c



With vertical and horizontal wall connections, the MX Tie must be tightly installed towards the wall connection in the specified order!

Vertical Wall Connection

(Fig. A11.02)

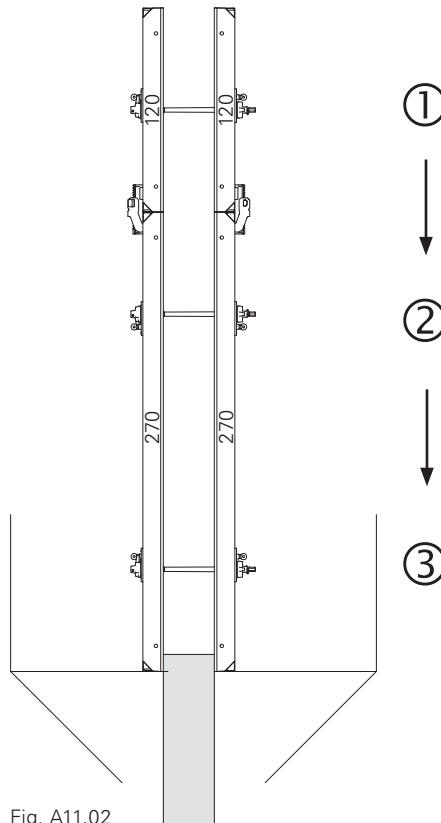

Fig. A11.02

Horizontal Wall Connection

Plan view (Fig. A11.03a + A11.03b)

Horizontal Wall connection

Section (Fig. A11.03c)

Waler MAR 85 (21) installed below.

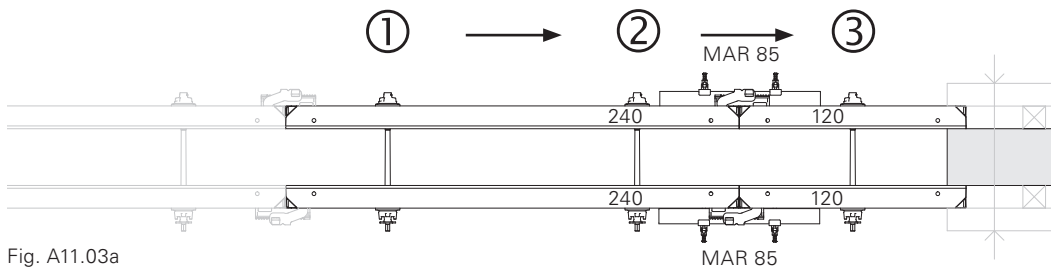

Fig. A11.03a

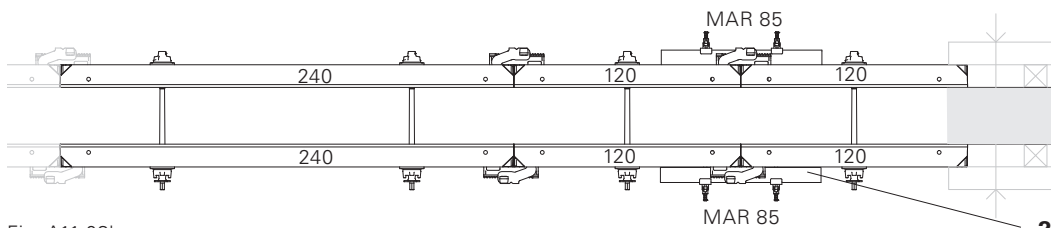

Fig. A11.03b

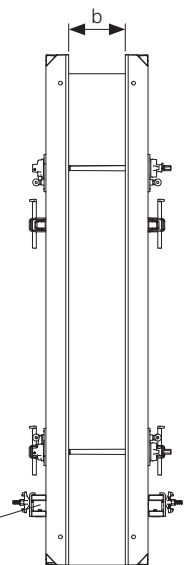

Fig. A11.03c

**On the first panel joint, a Compensation Waler MAR 85 (21) must always be mounted in the bottom area.
Exception: Panel $b > 120$ cm.**

B1 90° Corners with Inside Corner MXI 18, 270 x 50/20

Wall Thicknesses 15 – 40 cm

Outside Corner MXA 270 x 45



Perm. fresh concrete pressure: 80 kN/m²

Components

20	Alignment Coupler BFD
100	Panel MXM 18, 270 x 60
101	Panel MX 18, 270 x 30
102	Panel MX 18, 270 x 45
106	Panel MX 18, 270 x 240
140	Wall Thickness Compensator WDA MX 270 or filler timber supplied by contractor ≤ 10 cm
151	Outside Corner MXA 270 x 45
153	Inside Corner MXI 18, 270 x 50/20

Examples

- Wall thickness 15:
Fig. B1.01 + B1.05a + B1.05b
- Wall thickness 17.5:
Fig. B1.02 + B1.05a + B1.05b
- Wall thickness 20:
Fig. B1.03 + B1.05a + B1.05b
- Wall thickness 24 / 25:
Fig. B1.04 + B1.05a + B1.05b
- Wall thickness 30:
Fig. B1.05 + B1.05a + B1.05b
- Wall thickness 35 / 36:
Fig. B1.06 + B1.05a + B1.05b
- Wall thickness 40:
Fig. B1.07 + B1.05a + B1.05b

Compensations

- Wall thickness 25 + 36 + 40 cm:
without compensation
- Wall thickness 15 + 17.5 cm:
internal and external compensation
- Wall thickness 20 + 24 cm:
internal compensation
- Wall thickness 30 + 35 cm:
external compensation

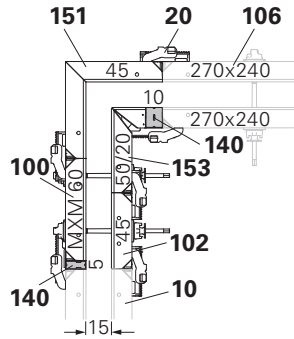

Fig. B1.01

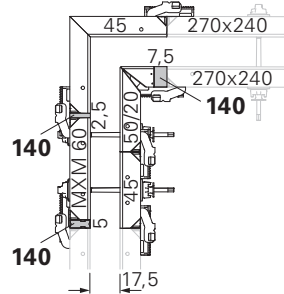

Fig. B1.02

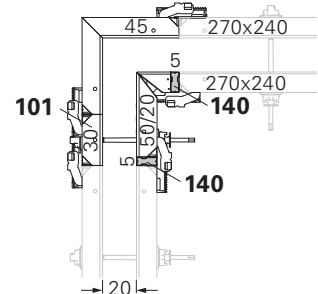

Fig. B1.03

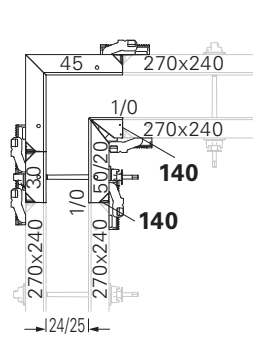

Fig. B1.04

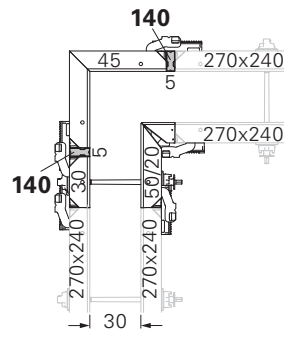

Fig. B1.05

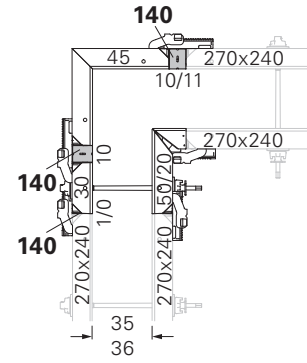

Fig. B1.06

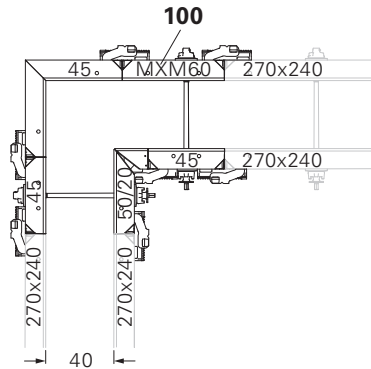

Fig. B1.07



90° Corners with Inside Corner MXI 18, ... x 60, see D2.

Alternatively – panel width 45

Max. panel width between corner and subsequent panel is 45 cm – MX 18, 270 x 45 (102). (Fig. B1.08)

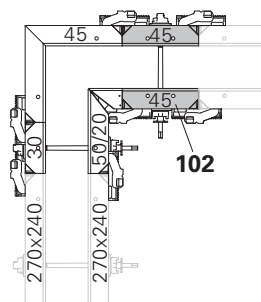

Fig. B1.08

B1 90° Corners with Inside Corner MXI 18, 270 x 50/20

Arrangement of the Alignment Couplers

Valid for wall thicknesses 15 – 40 cm.

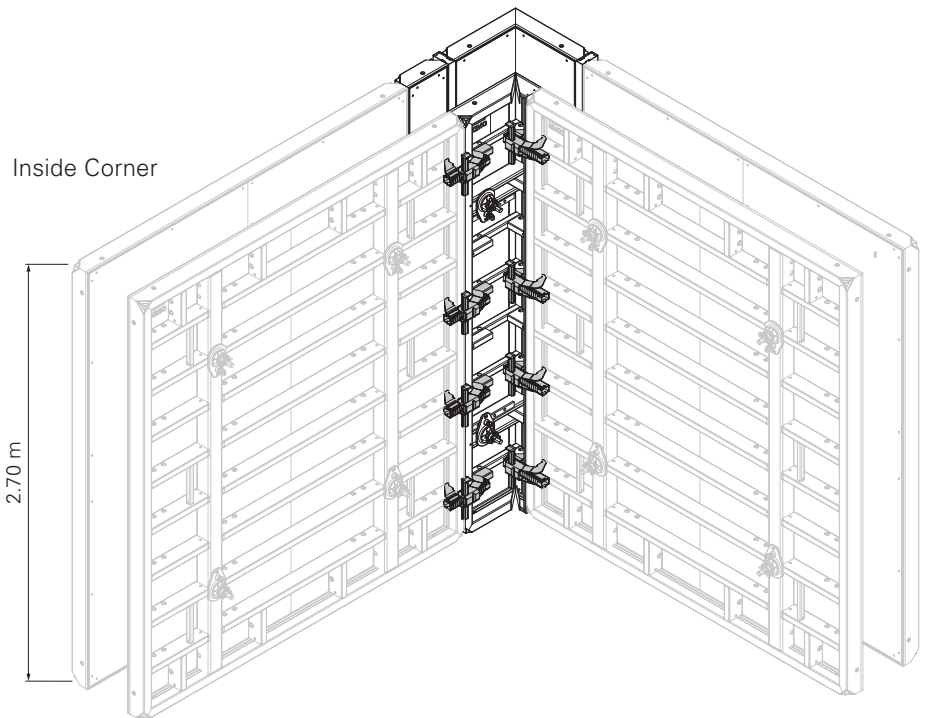

Fig. B1.05a

Outside Corner

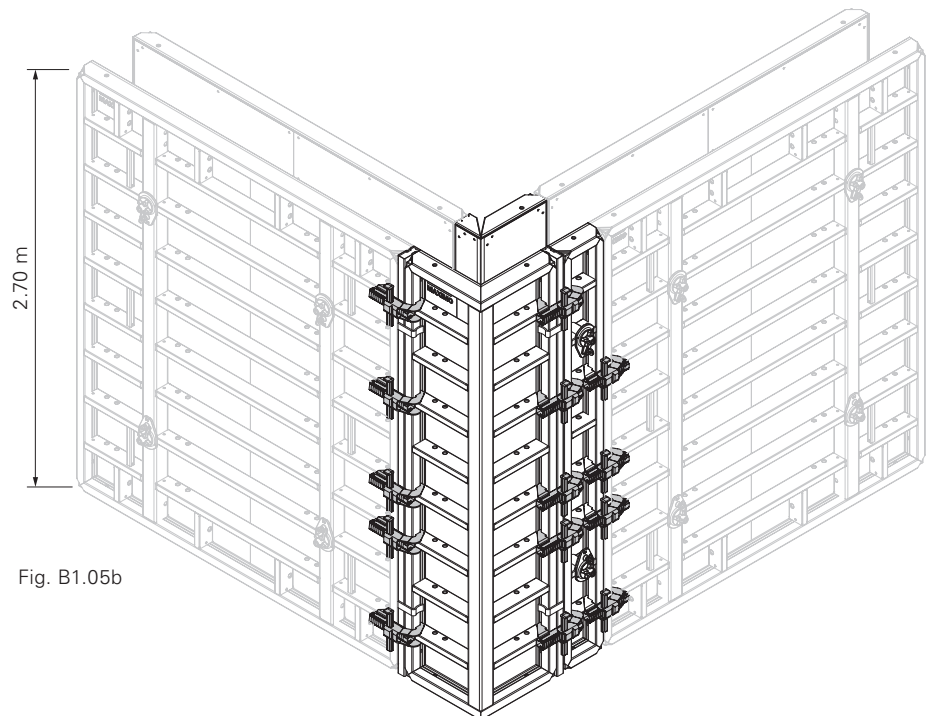

Fig. B1.05b

B1 90° Corners with Inside Corner MXI 18, 270 x 50/20

Wall Thicknesses > 40 – 60 cm

Outside Corner MXA 270 x 45



Perm. fresh concrete pressure: 60 kN/m²

Components

- 10** Panel MX 18, 270 x 240
- 20** Alignment Coupler BFD
- 21** Compensation Waler MAR 85/3
- 22** Compensation Waler MAR 170/3
- 100** Panel MXM 18, 270 x 60
- 101** Panel MX 18, 270 x 30
- 102** Panel MX 18, 270 x 45
- 140** Wall Thickness Compensator WDA MX 270 or filler timber supplied by contractor ≤ 10 cm
- 151** Outside Corner MXA 270 x 45
- 153** Inside Corner MXI 18, 270 x 50/20

Examples

- Wall thickness 45:
Fig. B1.09 + B1.09a + B1.09b
- Wall thickness 50:
Fig. B1.10 + B1.09a + B1.09b
- Wall thickness 55:
Fig. B1.11 + B1.11a + B1.11b
- Wall thickness 60:
Fig. B1.12 + B1.11a + B1.11b

Compensations

- Wall thickness 45 + 50 + 60 cm:
External compensation
- Wall thickness 55 cm:
without compensation

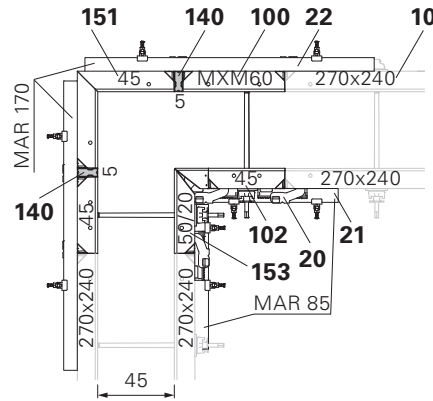

Fig. B1.09

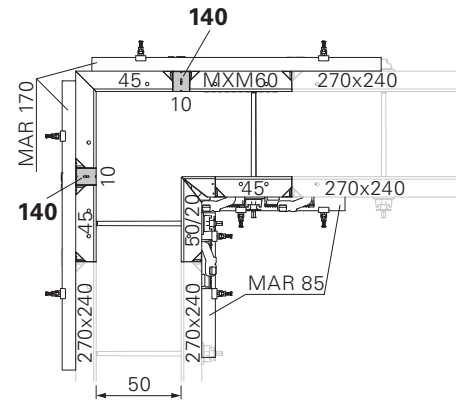

Fig. B1.10

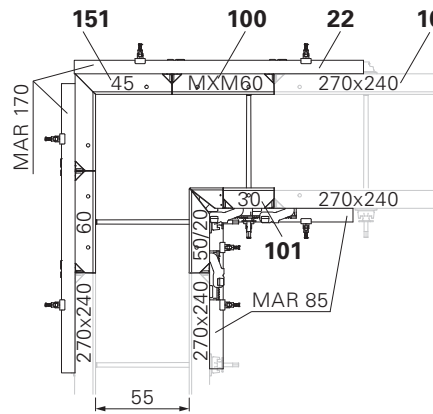

Fig. B1.11

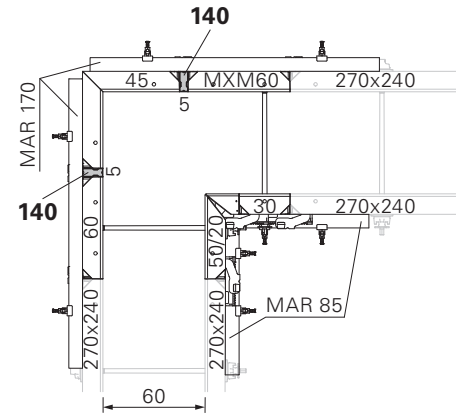

Fig. B1.12



- Offset mounting of BFD Alignment Couplers between
- Corner 50/20,
 - Panel ... x 30,
 - as well as the next Panel ... x 240.

„X“

of Fig. B1.11a

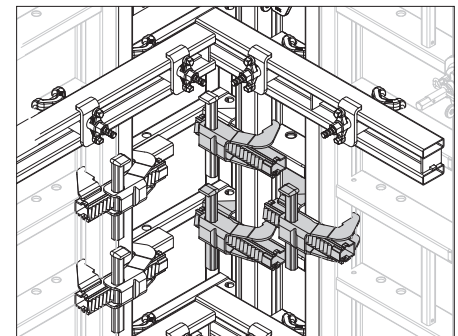

Fig. B1.11c

B1 90° Corners with Inside Corner MXI 18, 270 x 50/20

Arrangement of the Alignment Couplers and Compensation Walers

Valid for wall thicknesses > 40 – 50 cm.
(Fig. B1.09a + B1.09b)

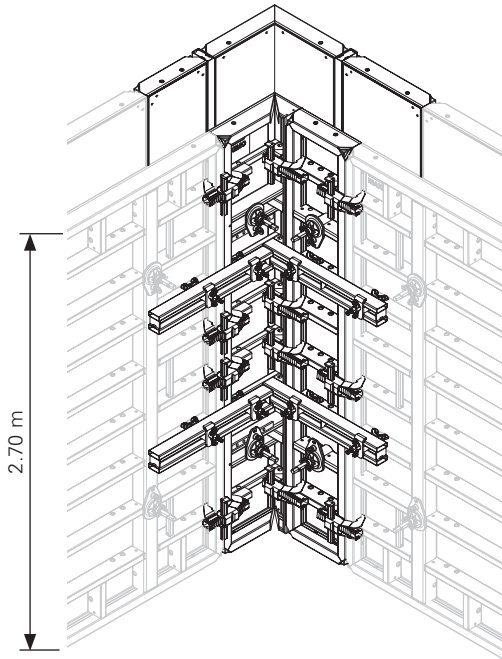

Fig. B1.09a

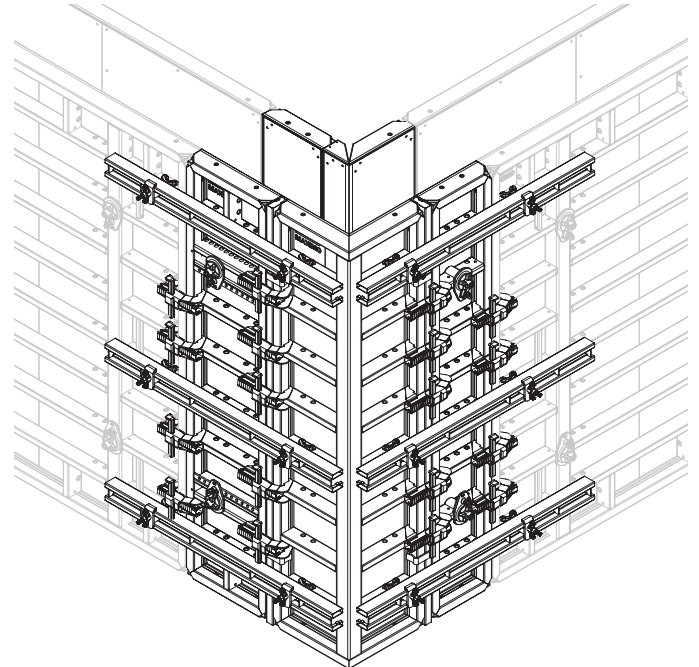

Fig. B1.09b

Valid for wall thicknesses > 50 – 60 cm
(Fig. B1.11a + B1.11b)

„X“
see Fig. B1.11c

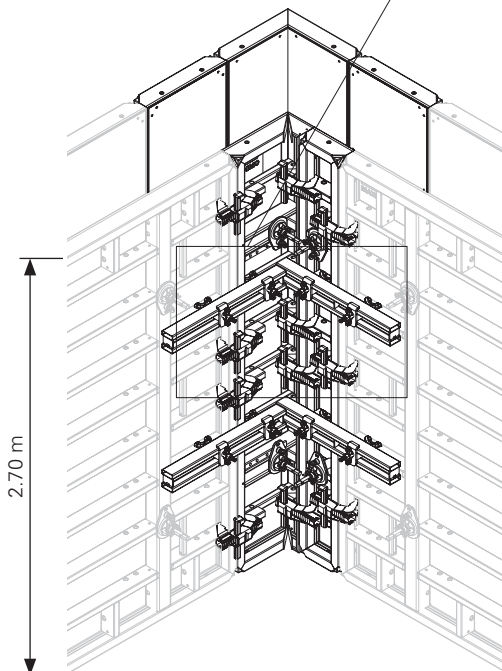

Fig. B1.11a

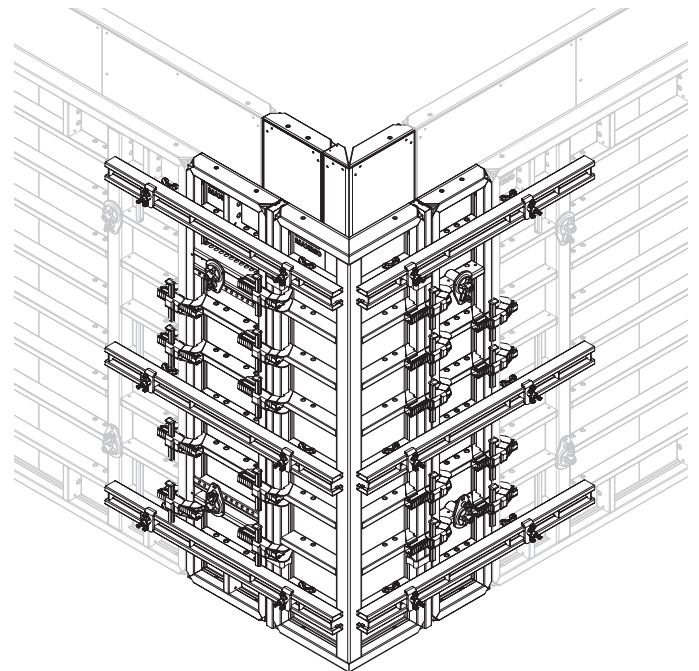

Fig. B1.11b

Panel connections

For panels with widths $b \leq 120$ following 90° corners, these must be strengthened at the next panel joint by means of a Compensation Waler MAR 85 (21).

With extensions, a second Compensation Waler MAR 85 is required on the panel joint (shown as a dotted line). (Fig. B2.01 + B2.01a + B2.01b)

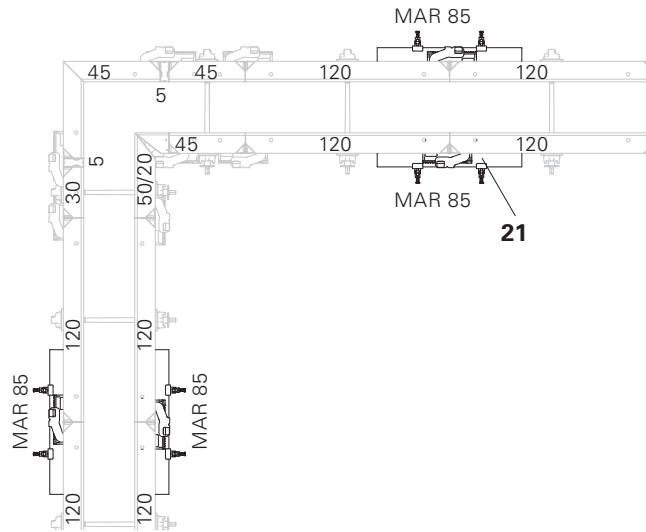

Fig. B2.01

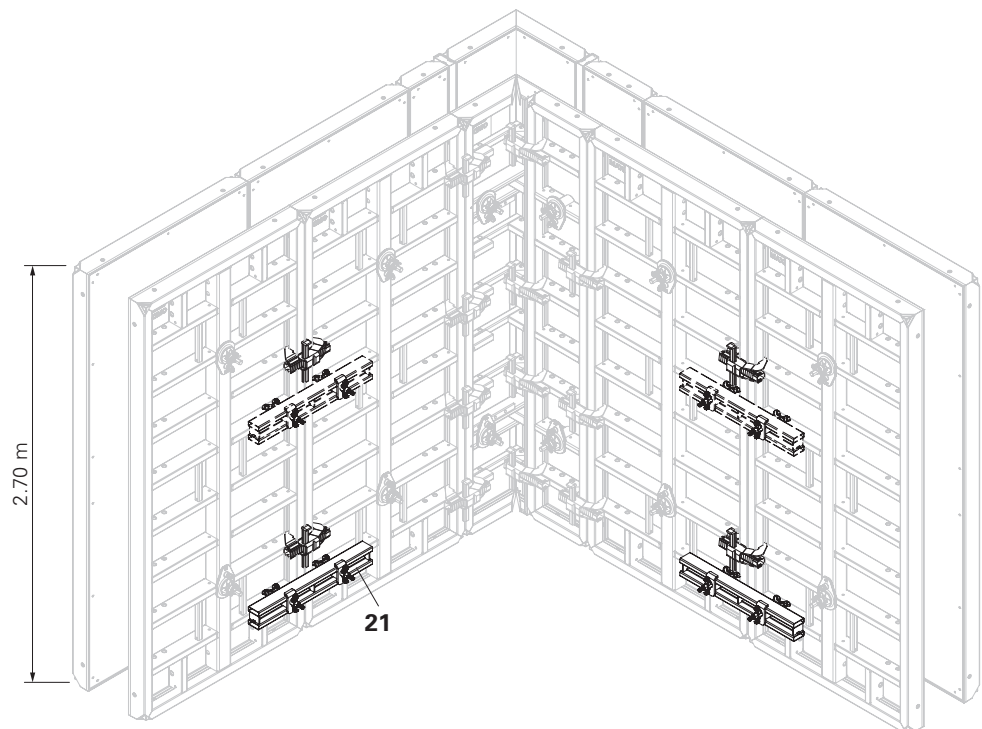

Fig. B2.01a

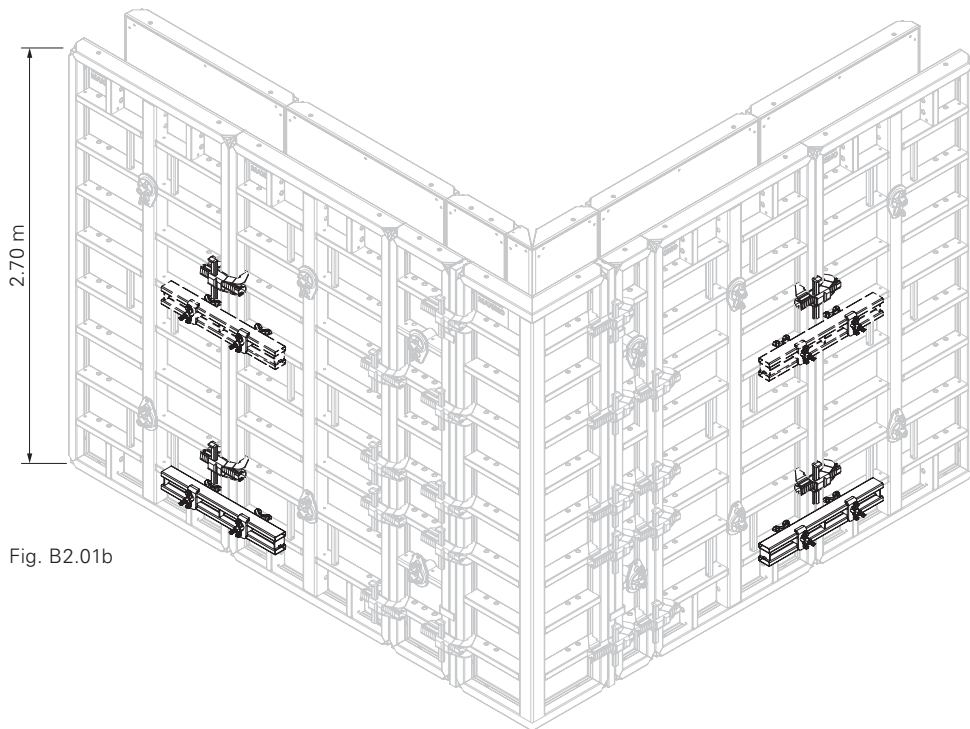

Fig. B2.01b

B3 90° T-junctions with Inside Corner MXI 18, 270 x 50/20

Wall Thicknesses 15 – 40 cm



Perm. fresh concrete pressure: 80 kN/m²

Components

10	Panel MX 18, 270 x 240
20	Alignment Coupler BFD
100	Panel MXM 18, 270 x 60
102	Panel MX 18, 270 x 45
103	Panel MX 18, 270 x 60
140	Wall Thickness Compensator WDA MX 270 or filler timber supplied by contractor ≤ 10 cm
153	Inside Corner MXI 18, 270 x 50/20

Assembly

1. Form the T-junction with Inside Corner MXI 18, 50/20 (153).
2. Form the opposite straight wall with Panels MX 18, 45 (102), MX 18, 60 (103), or MXM 60 (100) – according to the wall thickness.
3. Install compensation (140) according to the wall thickness.

Examples

- Wall thickness 15:
Fig. B3.01 + B3.05a + B3.05b
- Wall thickness 17.5:
Fig. B3.02 + B3.05a + B3.05b
- Wall thickness 20:
Fig. B3.03 + B3.05a + B3.05b
- Wall thickness 24/25:
Fig. B3.04 + B3.05a + B3.05b
- Wall thickness 30:
Fig. B3.05 + B3.05a + B3.05b
- Wall thickness 35/36:
Fig. B3.06 + B3.05a + B3.05b
- Wall thickness 40:
Fig. B3.07 + B3.05a + B3.05b

Compensations

- Wall thickness 15 + 17.5 + 24 + 25 + 30 + 35 + 36 + 40 cm:
external compensation
- Wall thickness 20:
without compensation



90° T-junctions with Inside Corners MXI 18, ... x 60, see D3.

Alternatively – panel width 45

Max. panel width at the T-junction between corner and subsequent panel is 45 cm – MX 18, 270 x 45 (102). (Fig. B3.08)

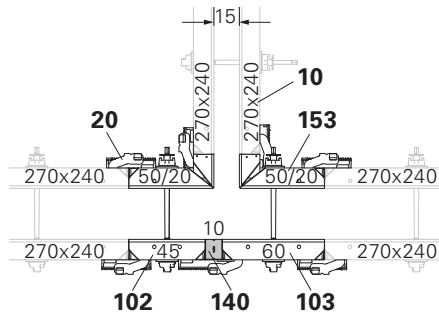

Fig. B3.01

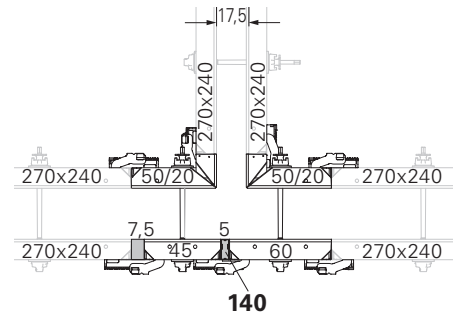

Fig. B3.02

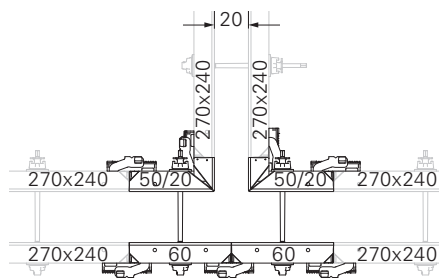

Fig. B3.03

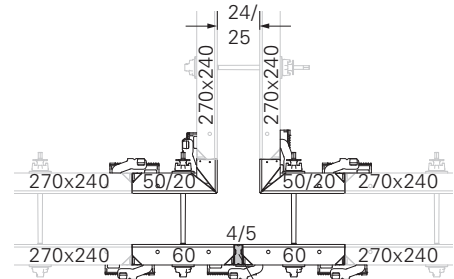

Fig. B3.04

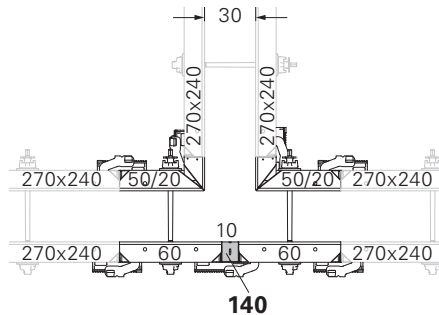

Fig. B3.05

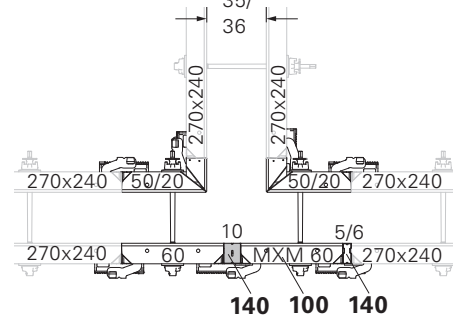

Fig. B3.06

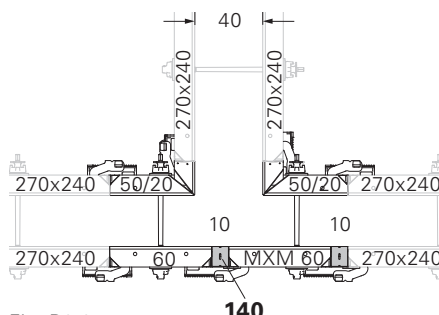

Fig. B3.07

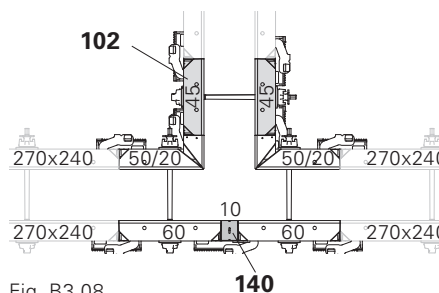
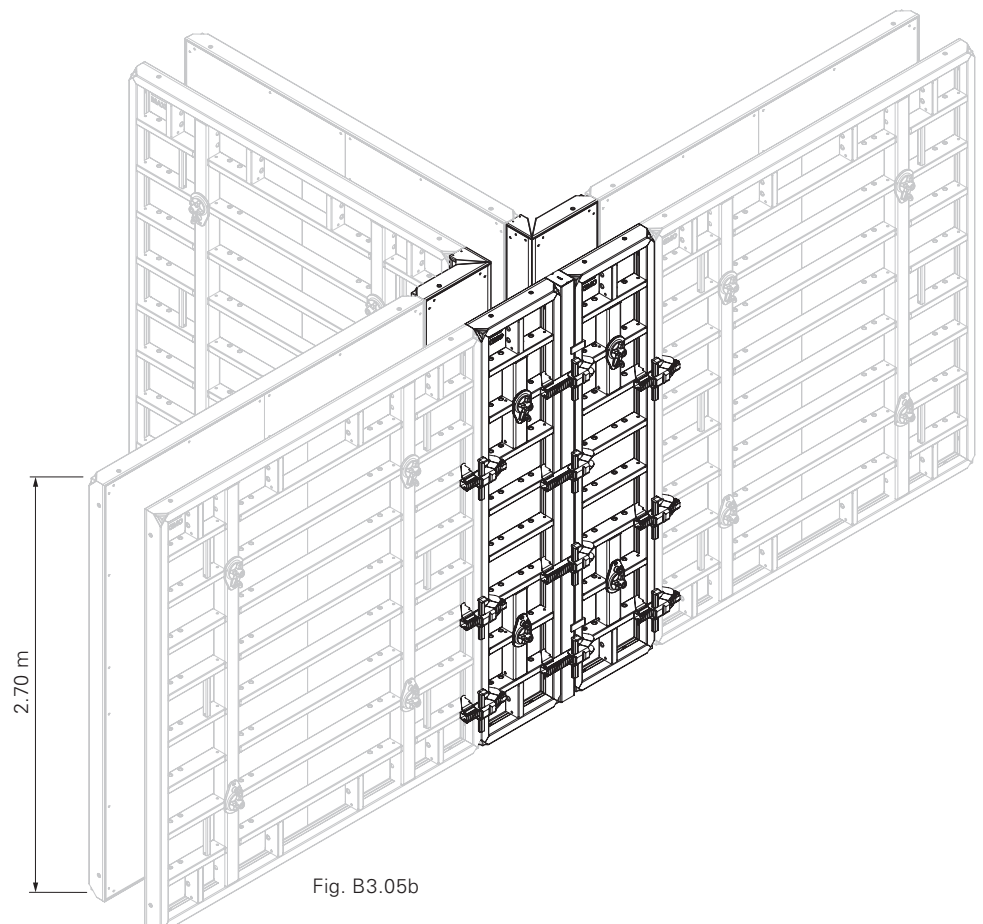
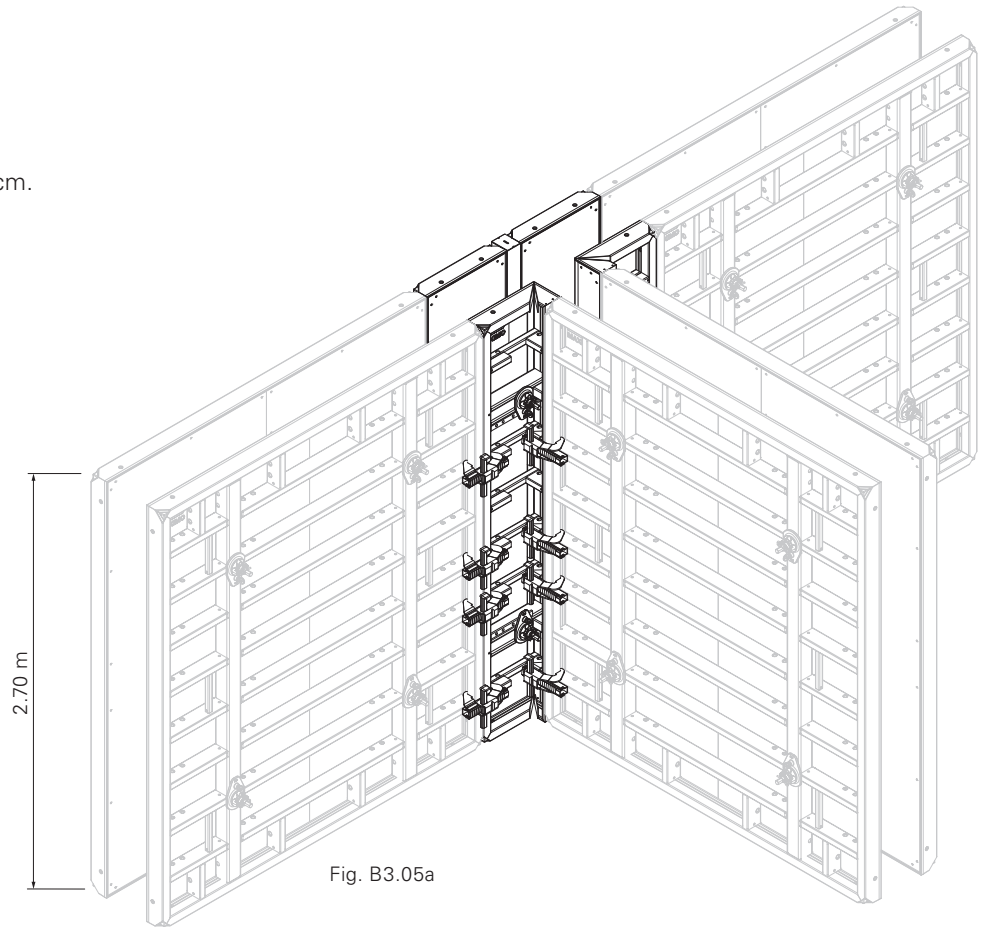

Fig. B3.08

B3 90° T-junctions with Inside Corner MXI 18, 270 x 50/20

Arrangement of the Alignment Couplers

Valid for wall thicknesses 15 – 40 cm.
(Fig. B3.05a + B3.05b)



B3 90° T-junctions with Inside Corner MXI 18, 270 x 50/20

Wall thicknesses > 40 – 60 cm



Perm. fresh concrete pressure: 60 kN/m²

Components

10	Panel MX 18, 270 x 240
20	Alignment Coupler BFD
22	Compensation Waler MAR 170-3
102	Panel MX 18, 270 x 45
103	Panel MX 18, 270 x 60
140	Wall Thickness Compensator WDA MX 270 or filler timber supplied by contractor ≤ 10 cm
153	Inside Corner MXI 18, 270 x 50/20

Assembly

1. Form the T-junction with Inside Corner MXI 50/20 (153).
Form the opposite straight wall with Panels MX 18, 45 (102) or MX 18, 60 (103) – according to the wall thickness.
2. Install compensation (140) according to the wall thickness.
3. On the straight wall, install Compensation Waler MAR 170 (22) centrally to the outgoing wall.

Examples

- Wall thickness 45:
Fig. B3.09 + B3.09a + B3.09b
- Wall thickness 50:
Fig. B3.10 + B3.09a + B3.09b
- Wall thickness 55:
Fig. B3.11 + B3.09a + B3.09b
- Wall thickness 60:
Fig. B3.12 + B3.09a + B3.09b

Compensations

- Wall thickness 45 + 55 + 60 cm:
external compensation
- Wall thickness 50:
without compensation



90° T-junctions with Inside Corner MXI 18, ... x 60, see Section D3.

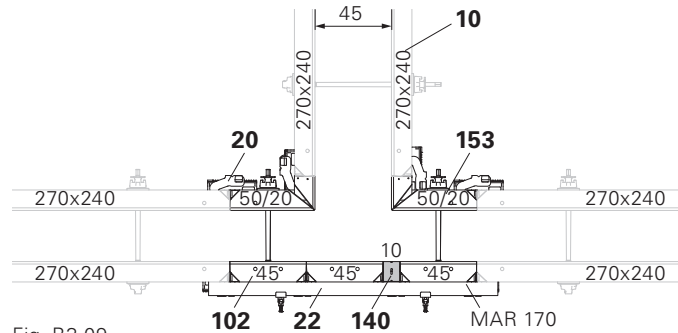

Fig. B3.09

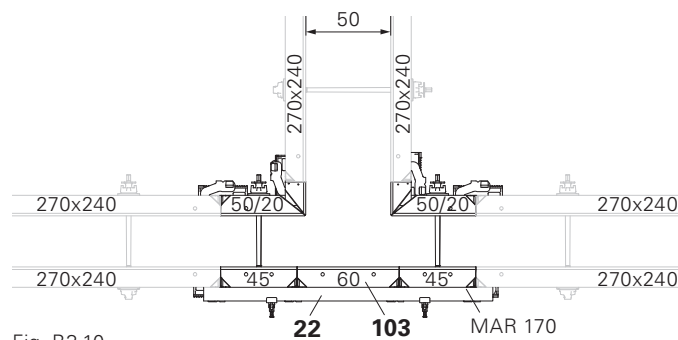

Fig. B3.10

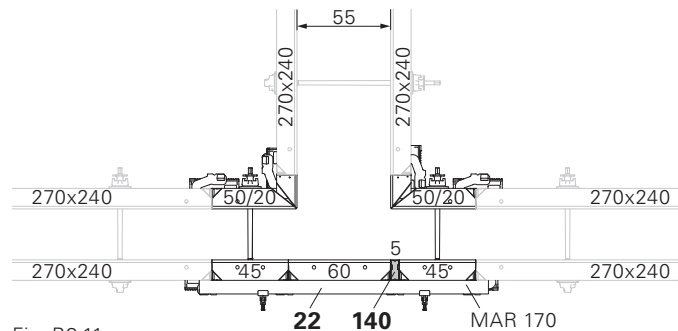

Fig. B3.11

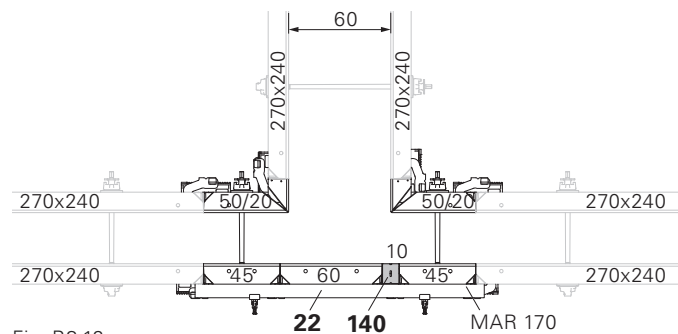

Fig. B3.12

B3 90° T-junctions with Inside Corner MXI 18, 270 x 50/20

Arrangement of the Alignment Couplers and Compensation Walers

Valid for wall thicknesses 45 – 60 cm.
(Fig. B3.09a + B3.09b)

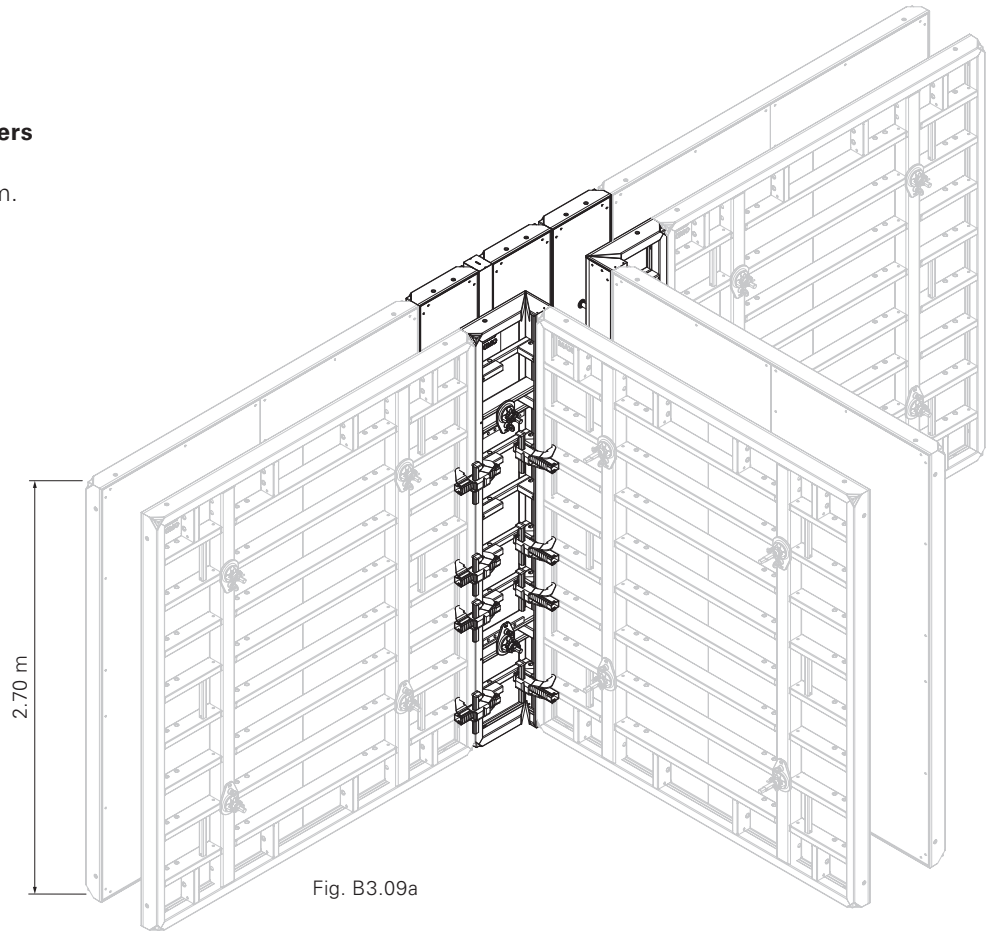

Fig. B3.09a

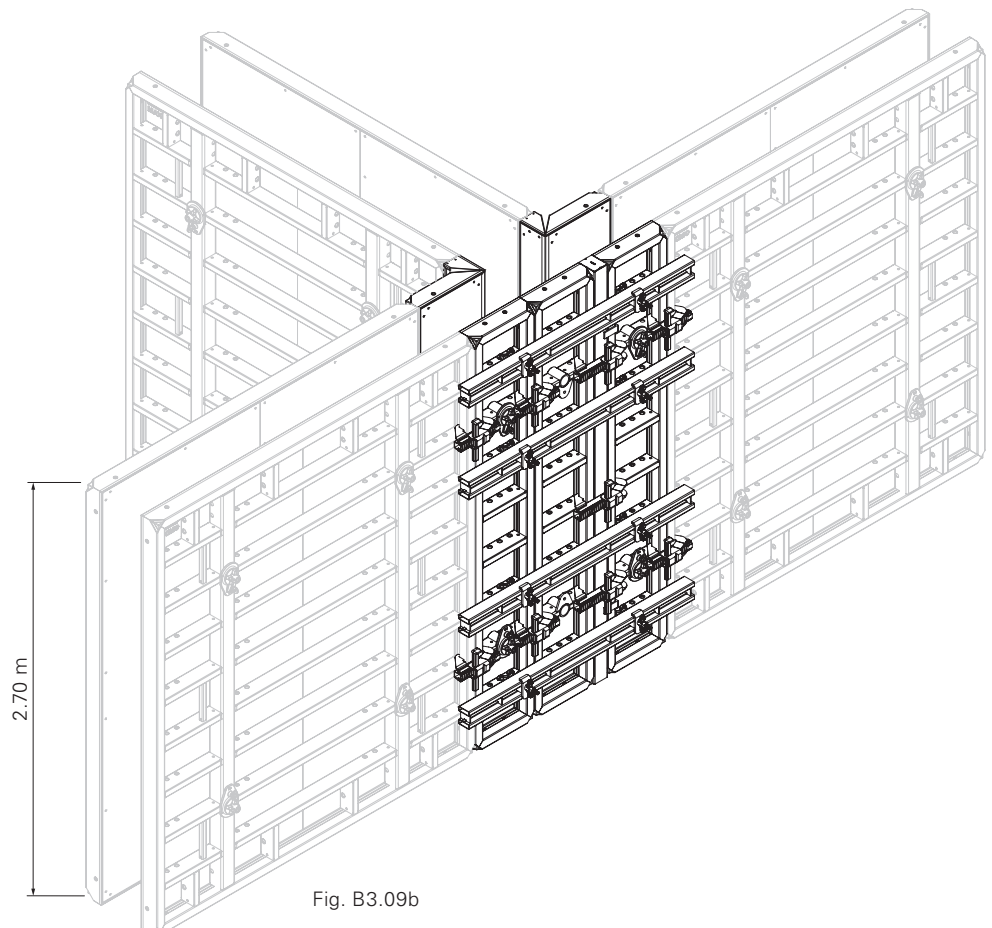

Fig. B3.09b

B4 Panel Connections following 90° T-junctions

Panel connections

For panels with widths $b \leq 120$ following 90° T-junctions, these must be strengthened at the next panel joint by means of a Compensation Waler MAR 85 (21).

With extensions, a second Compensation Waler MAR 85 is required on the panel joint (shown as a dotted line).

(Fig. B4.01 + B4.01a + B4.01b)

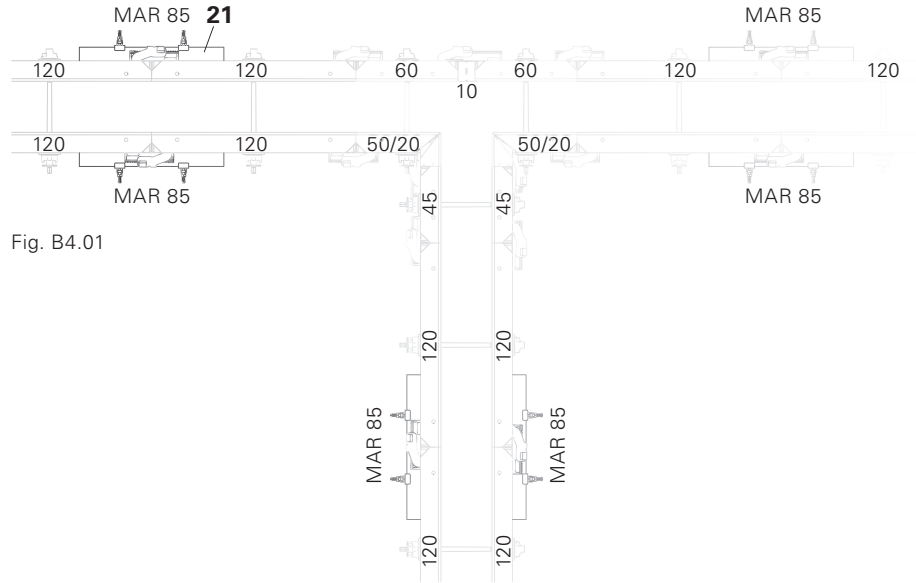

Fig. B4.01

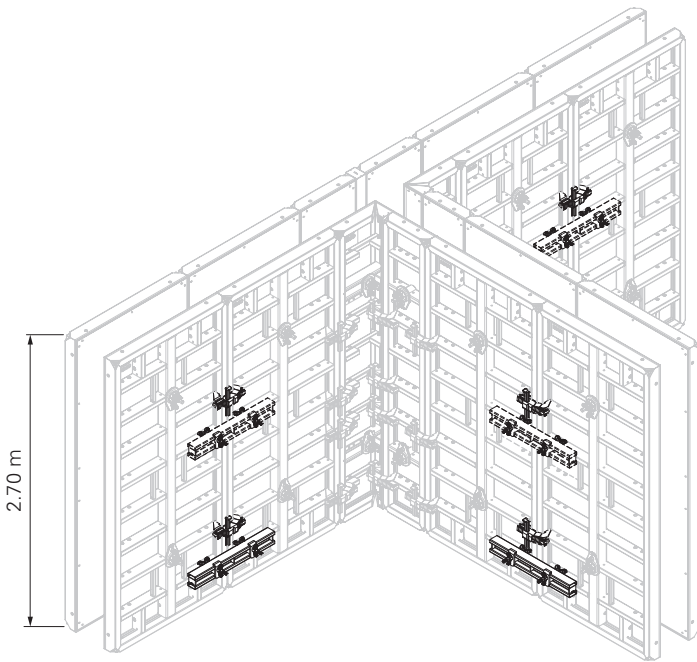

Fig. B4.01a

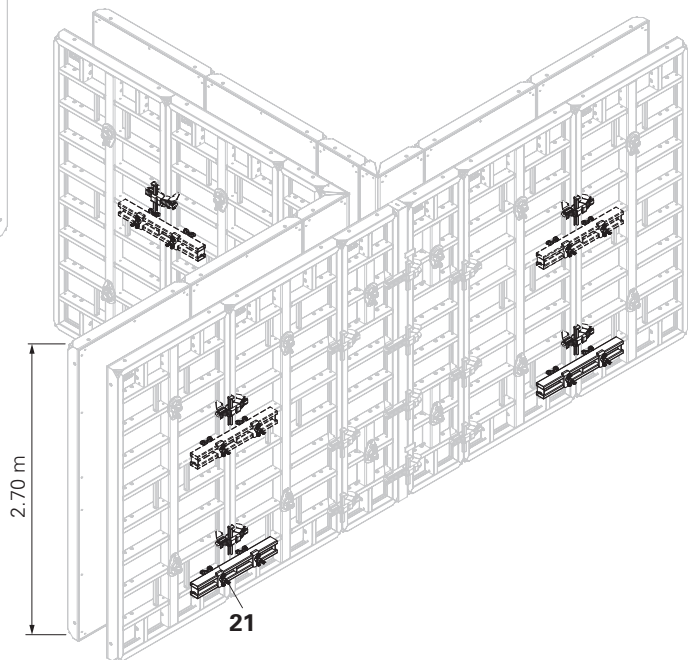

Fig. B4.01b

Wall Thickness Compensator WDA MX 270

Length compensation up to 10 cm.

Components

20	Alignment Coupler BFD	3x
50	Timber	1x



No ties required!

The length is compensated with Wall Thickness Compensator MX or using timber which has been cut to size (50).
Note: number and arrangement of the BFD Alignment Couplers (20).
(Fig. B5.01)

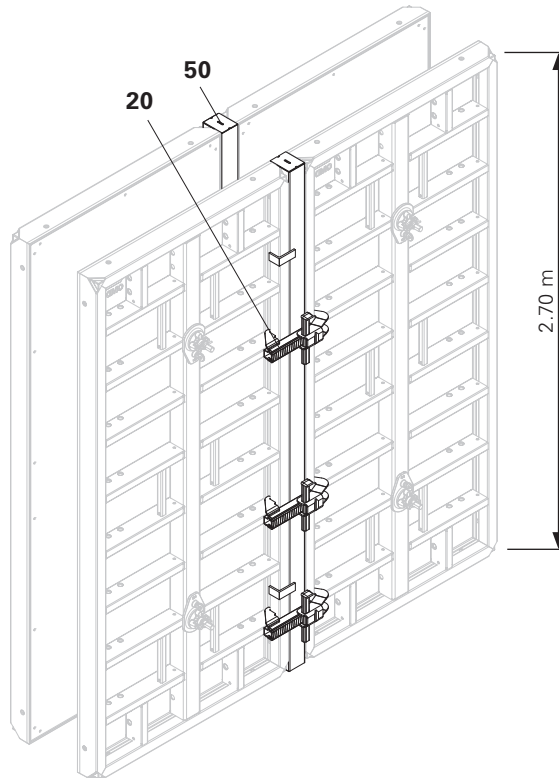

Fig. B5.01

Filler Profile TPP

Length compensation (b) from 10 to 36 cm.



- Perm. fresh concrete pressure 80 kN/ m² for:
b ≥ 10 and b < 30 mm.
- Perm. fresh concrete pressure: 60 kN/ m² for:
b ≥ 30 and b ≤ 36 mm.

Components

20	Alignment Coupler BFD	4x
21	Compensation Waler MAR 85	2x
51	Plywood filler 21 mm	1x
52	Filler Profile TPP	2x

When anchoring, ensure that the anchor forces are transferred centrally through the Compensation Waler MAR 85 (21) to the adjacent panels.
(Fig. B5.02b)

Installation (Fig. B5.02 + B5.02a)

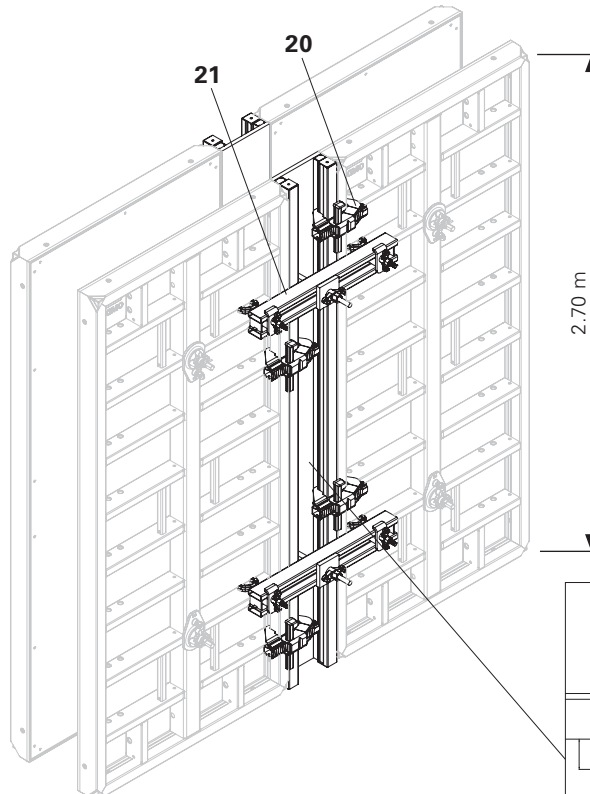

Fig. B5.02

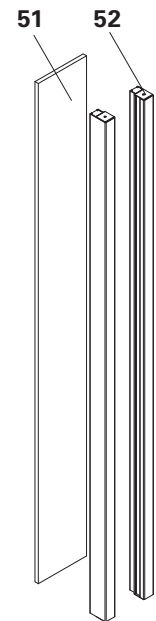

Fig. B5.02a

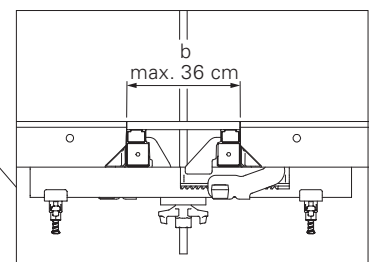

Fig. B5.02b

Stopend Formwork with Panel MX 18, 270 x 30

As Stopend Panel (101) for a wall thickness of 30 cm.
(Fig. B6.01)

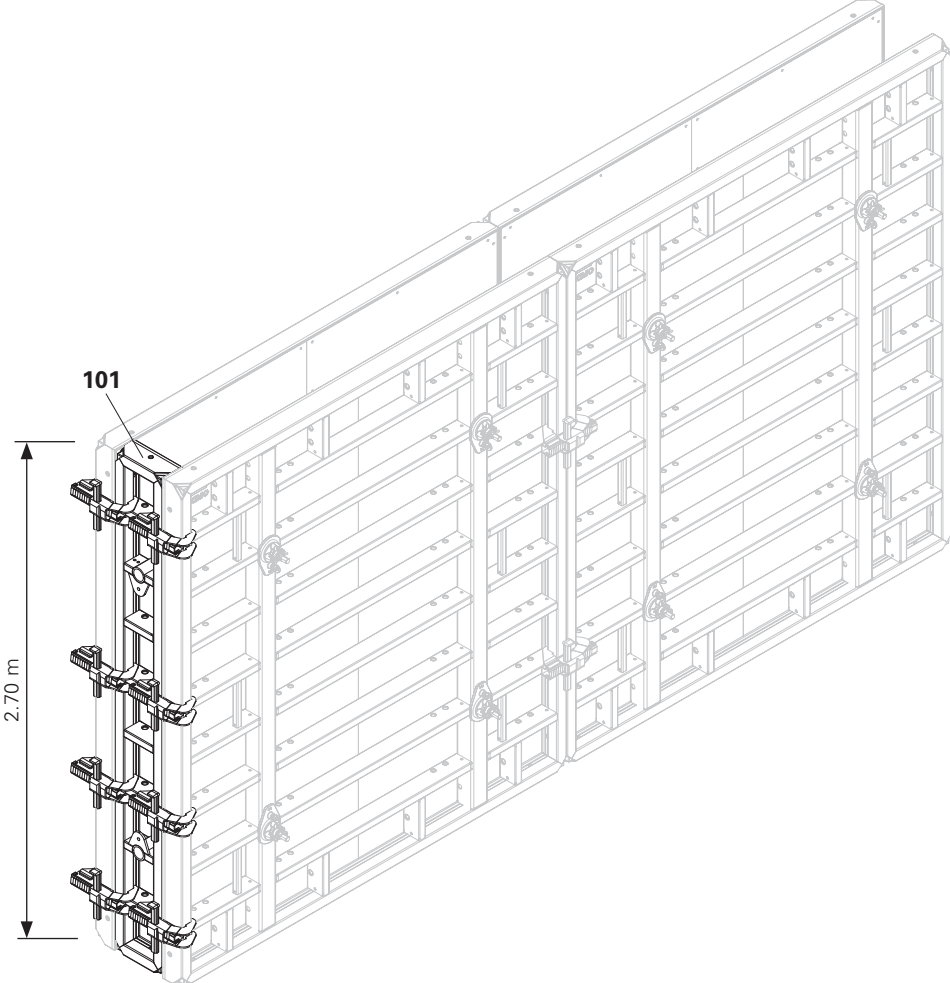

Fig. B6.01

Stopend Formwork with timber and plywood fillers

For wall thicknesses ≤ 40 cm.



The fresh concrete pressure of the stopend formwork is transferred to the MAXIMO Panels via the stopend ties and Waler 85.

With Panel **MX 18, 270 x 120** at the end of the wall. (Fig. B6.02 + B6.03)

Also valid for the following panels:

- MXI MX 18, 270 x 30
- MXI MX 18, 270 x 45
- MXI MX 18, 270 x 60
- MXI MX 18, 270 x 90

Connecting parts

21 Compensation Waler MAR 85 / alternatively: Waler 85	4x
23 Wingnut Pivot Plate DW 15	12x
25 Tie Rod DW 15	2x
26 Timber	2x
27 Top Tie Bracket-2 AH	4x
28 Stopend Tie TS	8x
51 Plywood filler 21 mm	1x

- Compensation Waler MAR 85 (21) with Stopend Tie (28) and Wingnut Pivot Plate (23), see Fig. B6.03b.
- Top Tie Bracket-2 AH with Tie Rod (25) and Wingnut Pivot Plate (23), see Fig. B6.03a.

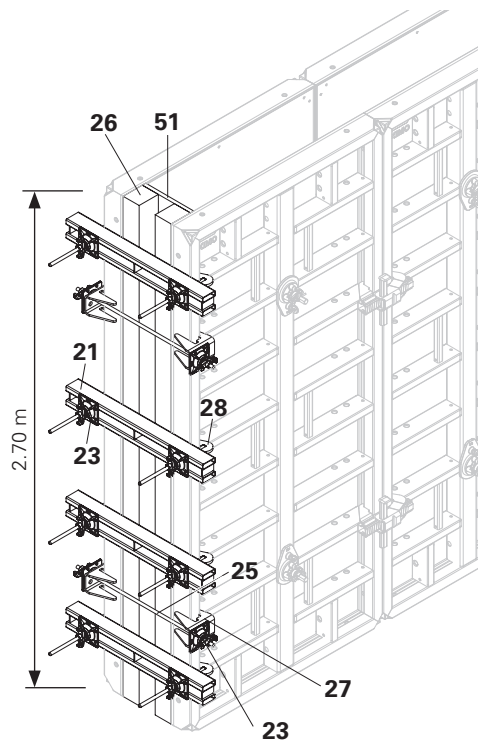

Fig. B6.02

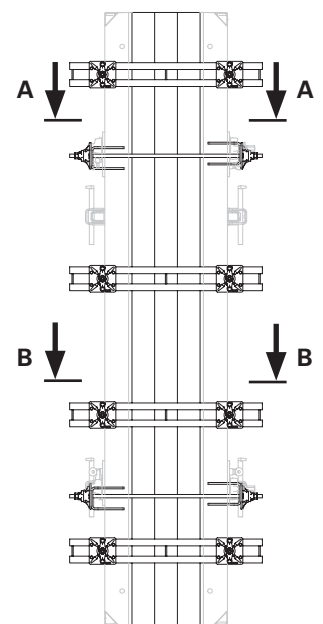

Fig. B6.03

With Panel **MX 18, 270 x 240** at the end of the wall. (without illustration)

Connecting parts

21 Compensation Waler MAR 85 / alternatively: Waler 85	4x
23 Wingnut Pivot Plate DW 15	8x
26 Timber	8x
28 Stopend Tie TS	2x
51 Plywood filler 21 mm	1x

Compensation Waler MAR 85 (21) with Stopend Tie (28) and Wingnut Pivot Plate (23), see Fig. B6.03b.

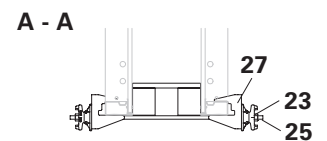

Fig. B6.03a

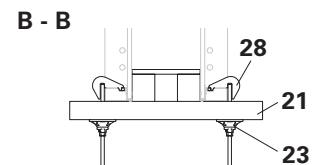

Fig. B6.03b

Stopend Panel Reinforcement

There are three possibilities available in order to install the stopend panel reinforcement.

- without water bar Installation – MT
- with water bar Installation – MTF
- with expandable water bar

Stopend panel reinforcement without water bar Installation MT

Height 2.70 m (Fig. B6.04a)

Height 1.20 m (Fig. B6.04b)

Consisting of:

- 2 x Outside Pieces AT 3 (55) for approx. 2.5 cm concrete cover or 2 x Outside Pieces AT 5 for approx. 5 cm concrete covering.
- 1 x Middle Piece MT (56).

(Fig. B6.05)



The rubber lip (55.1) allows a continuous reinforcement thickness of 16 mm.

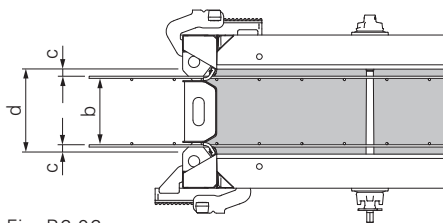

Fig. B6.06

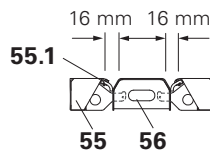

Fig. B6.05

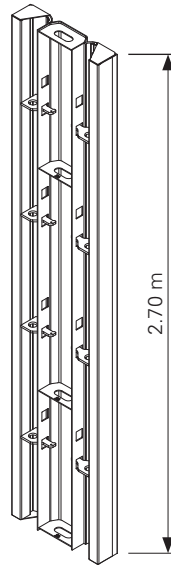

Fig. B6.04a

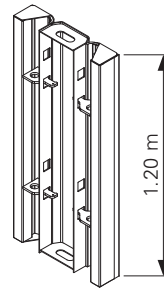

Fig. B6.04b

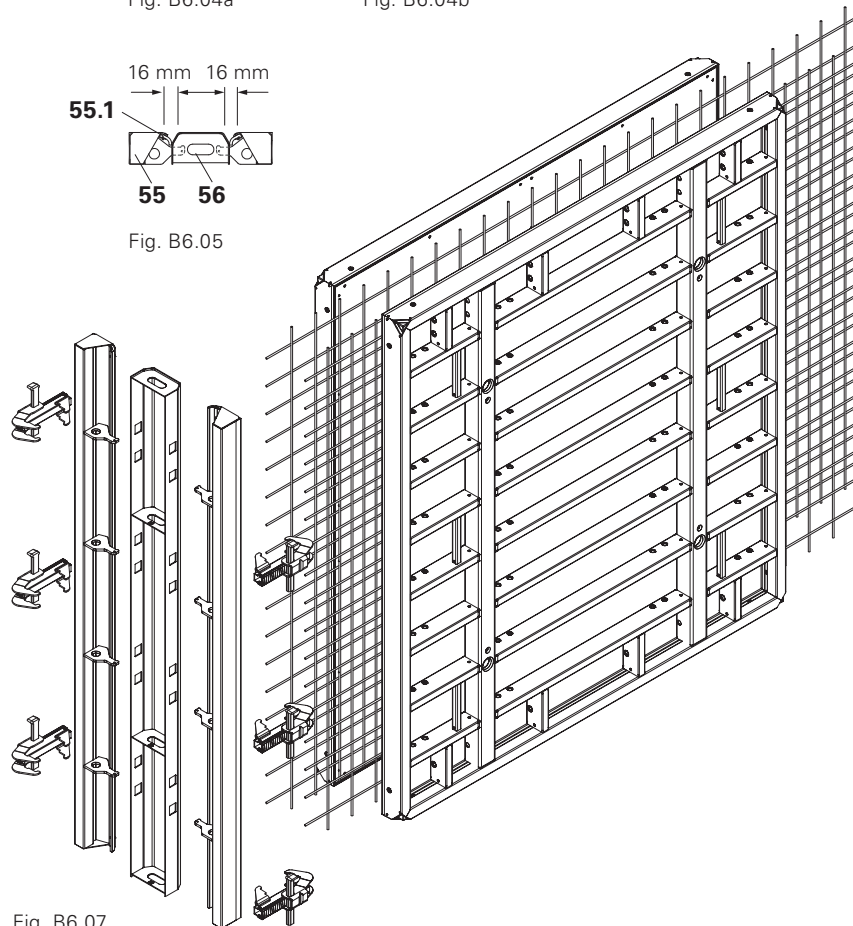

Fig. B6.07



Perm. fresh concrete pressure

dependent on the wall thickness,
 80 kN/m² for wall thickness ≤ 30 cm,
 70 kN/m² for wall thickness > 30 and
 wall thickness ≤ 35 cm,
 60 kN/m² for wall thickness > 35 and
 wall thickness ≤ 40 cm.

Assembly

1. Position primary formwork.
2. Fix Outside Piece AT (55) to the primary formwork by means of the Alignment Coupler BFD (20).
3. Install first row of reinforcement.
4. Position Centre Piece MT (56).
5. Install second row of reinforcement.
6. Fix Outside Piece AT to the primary formwork with Alignment Coupler BFD.
7. Position closing formwork and insert Outer Piece AT into the Centre Piece MTF.
8. Close formwork, and insert ties to secure.

(Fig. B6.07)

Stopend panel reinforcement with water bar Installation MTF

Height 2.70 m (Fig. B6.08a)

Height 1.20 m (Fig. B6.08b)

Consisting of:

- 2 x Outside Pieces AT 3 for approx. 2.5 cm concrete cover or 2 x Outside Pieces AT 5 for approx. 5 cm concrete covering.
- 1 x Centre Piece MTF (58) (Fig. B6.09)



The rubber lip allows a continuous reinforcement thickness of 16 mm.

Concrete cover c:

$$c = \frac{d - b}{2} - \varnothing \text{ Reinforcement}$$

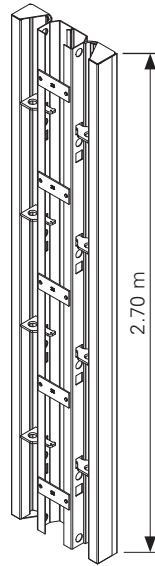
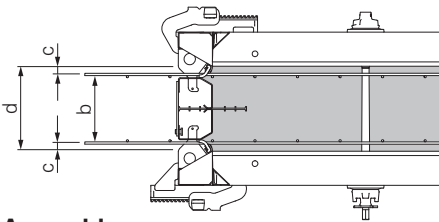

Fig. B6.08a

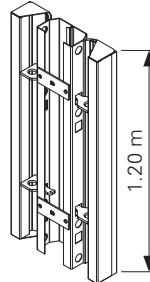

Fig. B6.08b

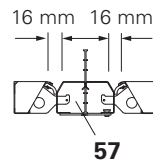

Fig. B6.09

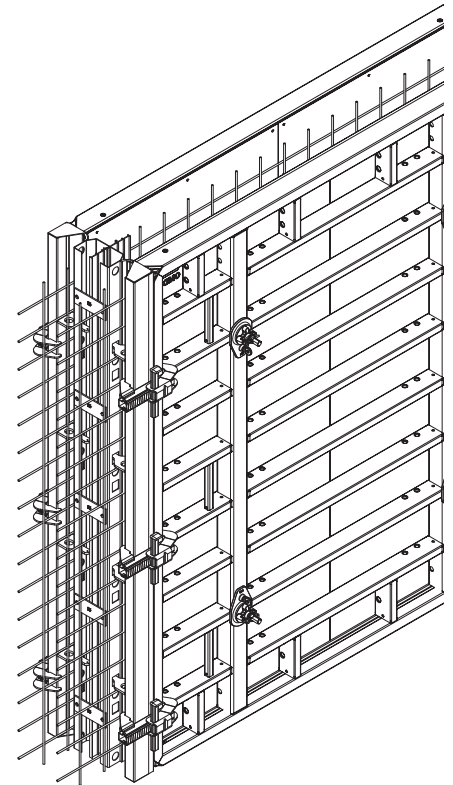

Fig. B6.10

Assembly

1. Position primary formwork.
2. Fix Outside Piece AT (56) to the primary formwork by means of Alignment Coupler BFD (20).
3. Install first row of reinforcement.
4. Position Centre Piece MTF (57) and install water bar.
5. Install second row of reinforcement.
6. Insert Outer Part AT into Centre Part MT and secure by means of Alignment Coupler BFD.
7. Position closing formwork.
8. Close formwork, and insert ties to secure.

(Fig. B6.10)

Stopend panel reinforcement with expandable water bar

Consisting of:

- 2 x Outside Pieces AT (56)
- 1 x Centre Piece MTF (58)
- Filler plates (51) supplied by the contractor

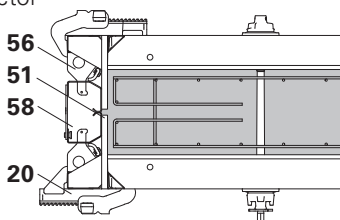

Height: 2.70 m
AT 270x3
AT 270x5

MT 270x20
MT 270x24/25
MT 270x30
MT 270x35/36

MTF 270x20
MTF 270x24/25
MTF 270x30
MTF 270x35/36

Height: 1.20 m
AT 120x3
AT 120x5

MT 120x20
MT 120x24/25
MT 120x30
MT 120x35/36

MTF 120x20
MTF 120x24/25
MTF 120x30
MTF 120x35/36

b [mm]	Wall thickness d [cm]							
	Concrete cover approx. 25 mm				Concrete cover approx. 50 mm			
-	2	24/25	30	35	24/25	30	35	40
-		2	2	2	2	2	2	2
	without water bar				without water bar			
118	1				1			
158		1				1		
218			1				1	
268				1				1
	with water bar				with water bar			
118	1				1			
158		1				1		
218			1				1	
268				1				1

-	2	2	2	2				
-					2	2	2	2
	without water bar				without water bar			
118	1				1			
158		1				1		
218			1				1	
268				1				1
	with water bar				with water bar			
118	1				1			
158		1				1		
218			1				1	
268				1				1

Extension Guidelines

Horizontal pre-assembly
up to 5.40 m high



Swivel nuts of the tie points must be mounted on the primary formwork!

Panel connections

For extension units height ≤ 5.40 m, Alignment Couplers BFD (20) are to be used on panel joints. (Fig. B7.01a – B7.01d)

Assembly information

The assembly surface must be level.

- Place timbers or planks in position as support.
- Pre-assemble extension units in a horizontal position, with the form-lining facing downwards.

MX 18, 270 x
30 / 45 / 60

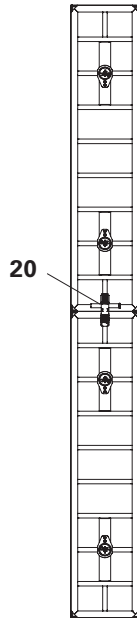

Fig. B7.01a

MX 18, 270 x
90 / 120

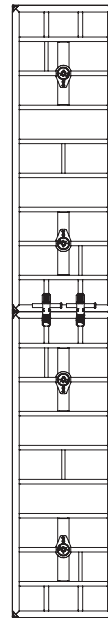

Fig. B7.01b

MX 18, 270 x 240

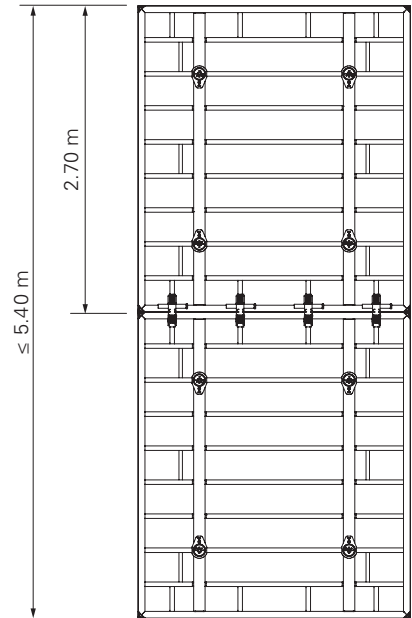

Fig. B7.01c

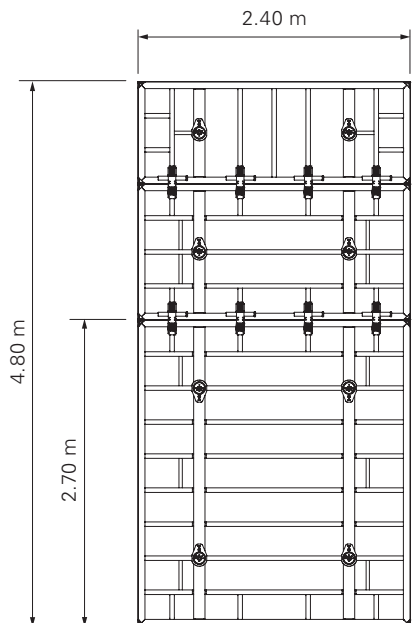

Fig. B7.01d

Erection with the crane

(Fig. B7.02)



- Do not exceed the permissible load-bearing capacity of the MAXIMO Lifting Hook and crane!
- Note: Instructions for Use for the MAXIMO Lifting Hook 1.5 t!

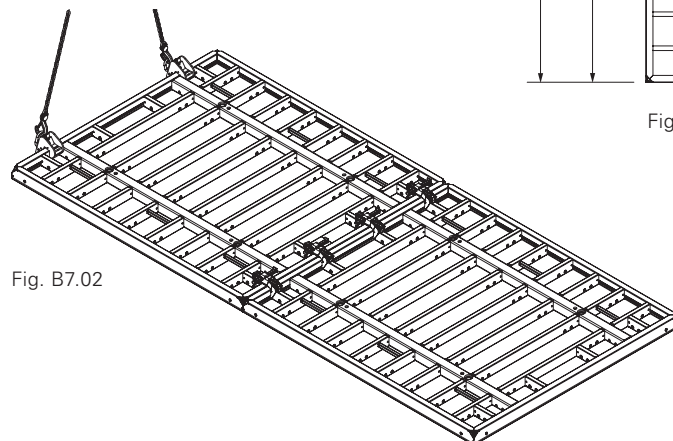

Fig. B7.02

Extension Guidelines

Horizontal pre-assembly
up to 8.10 m high



Swivel nuts of the tie points must be mounted on the primary formwork!

Panel connections

For extension units height ≤ 5.40 m,
Alignment Couplers BFD (20) and
Compensation Walers MAR 85 (21)
are to be used on panel joints.

(Fig. B7.03a – B7.03c)

Assembly information

- The assembly surface must be level.
- Place timbers or planks in position as support.
- Pre-assemble extension units in a horizontal position, with the form-lining facing downwards.

MX 18, 270 x
60 / 90 / 120

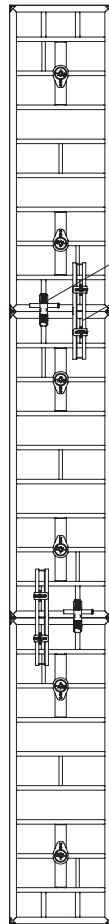

Fig. B7.03a

MX 18, 270 x 240

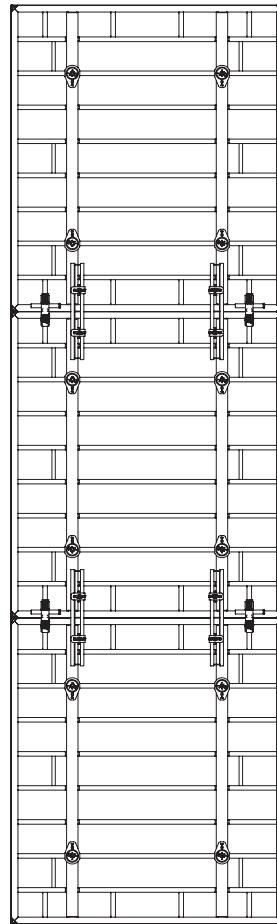

Fig. B7.03b

MX 18, 270 x 240
Panels horizontal

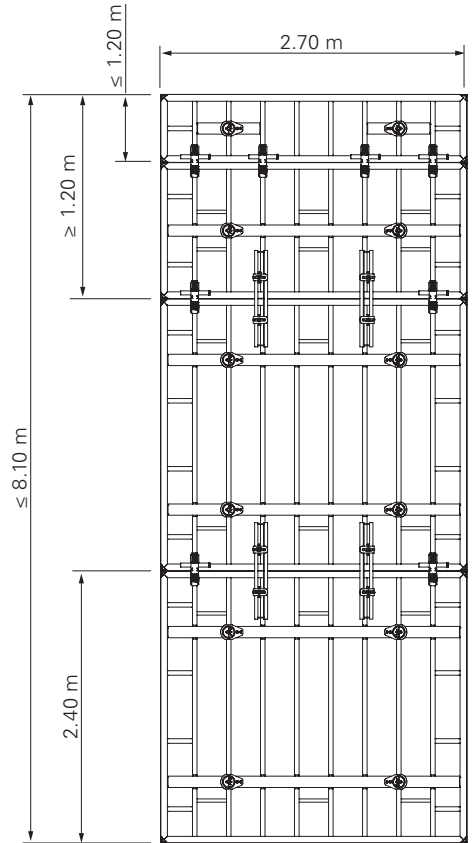

Fig. B7.03c

Erection with the crane

(Fig. B7.04)



- Do not exceed the permissible load-bearing capacity of the MAXIMO Lifting Hook and crane!
- Note: Instructions for Use for the MAXIMO Lifting Hook 1.5 t!

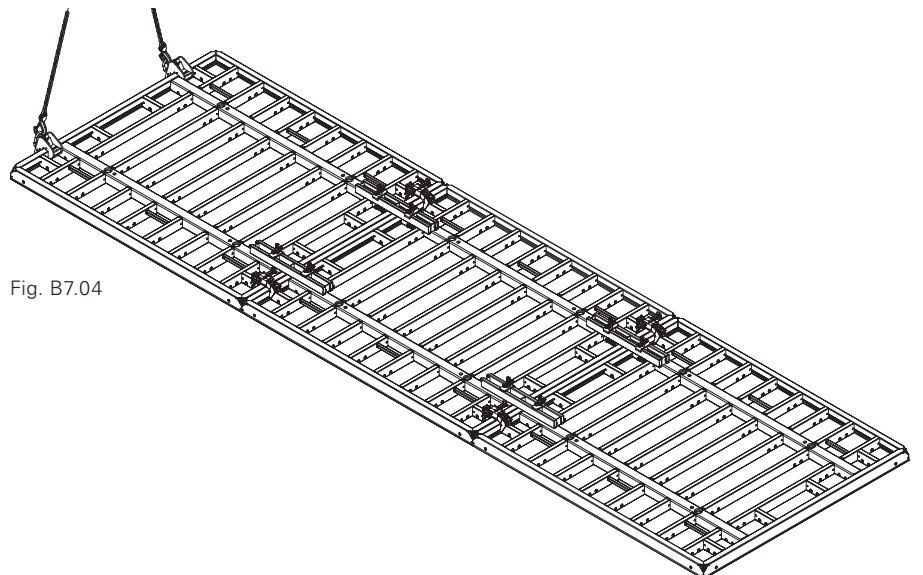

Fig. B7.04

C1 90° Corners with Inside Corner MXI 18, 330 x 50/20

Wall Thicknesses 15 – 40 cm

Outside Corner MX 330 x 45



Perm. fresh concrete pressure: 80 kN/m²

Components

- 20** Alignment Coupler BFD
- 120** Panel MXM 18, 330 x 60
- 122** Panel MX 18, 330 x 45
- 126** Panel MX 18, 330 x 240
- 142** Wall Thickness Compensator WDA (18) or filler timber supplied by contractor ≤ 10 cm
- 159** Outside Corner MXA 330 x 45
- 161** Inside Corner MXI 18, 330 x 50/20

Examples

- Wall thickness 15
Fig. C1.01 + C1.05a + C1.05b
- Wall thickness 17.5
Fig. C1.02 + C1.05a + C1.05b
- Wall thickness 20
Fig. C1.03 + C1.05a + C1.05b
- Wall thickness 24 / 25
Fig. C1.04 + C1.05a + C1.05b
- Wall thickness 30
Fig. C1.05 + C1.05a + C1.05b
- Wall thickness 35 / 36
Fig. C1.06 + C1.05a + C1.05b
- Wall thickness 40
Fig. C1.07 + C1.05a + C1.05b

Compensations

- Wall thickness 25 + 40 cm:
without compensation
- Wall thickness 15 + 17.5 cm:
internal and external compensation
- Wall thickness 20 + 24 cm:
internal compensation
- Wall thickness 30 + 35 + 36 cm:
external compensation



90° Corners with Inside Corner MXI 18, ... x 60, see D3.

Alternatively – panel width 45

Max. panel width between corner and subsequent panel is 45 cm – MX 18, 330 x 45 (122). (Fig. C1.08)

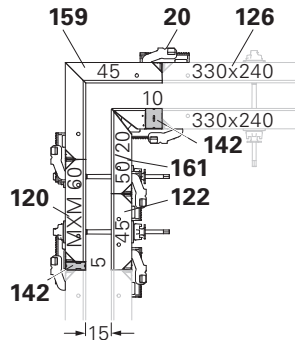

Fig. C1.01

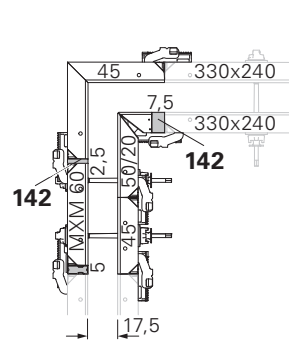

Fig. C1.02

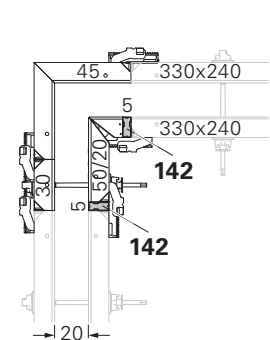

Fig. C1.03

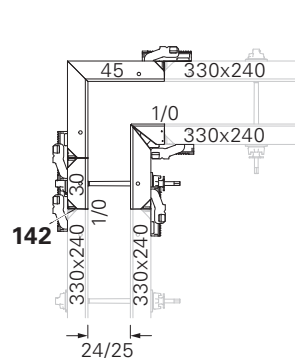

Fig. C1.04

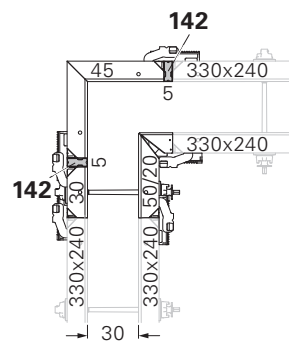

Fig. C1.05

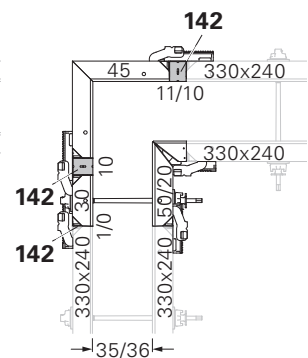

Fig. C1.06

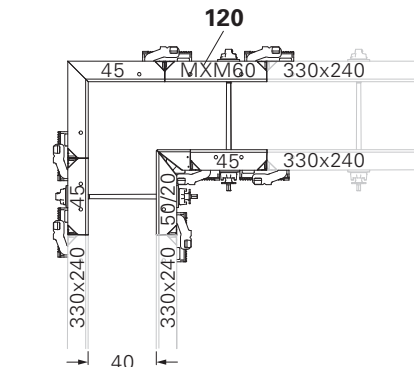

Fig. C1.07

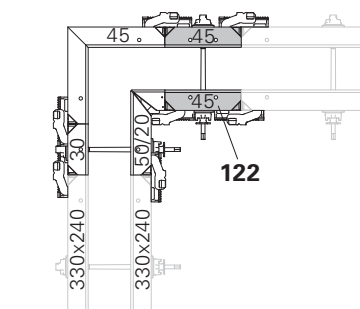

Fig. C1.08

C1 90° Corners with Inside Corner MXI 18, 330 x 50/20

Arrangement of the Alignment Couplers

Valid for wall thicknesses 15 – 40 cm.
(Fig. C1.05a + C1.05b)

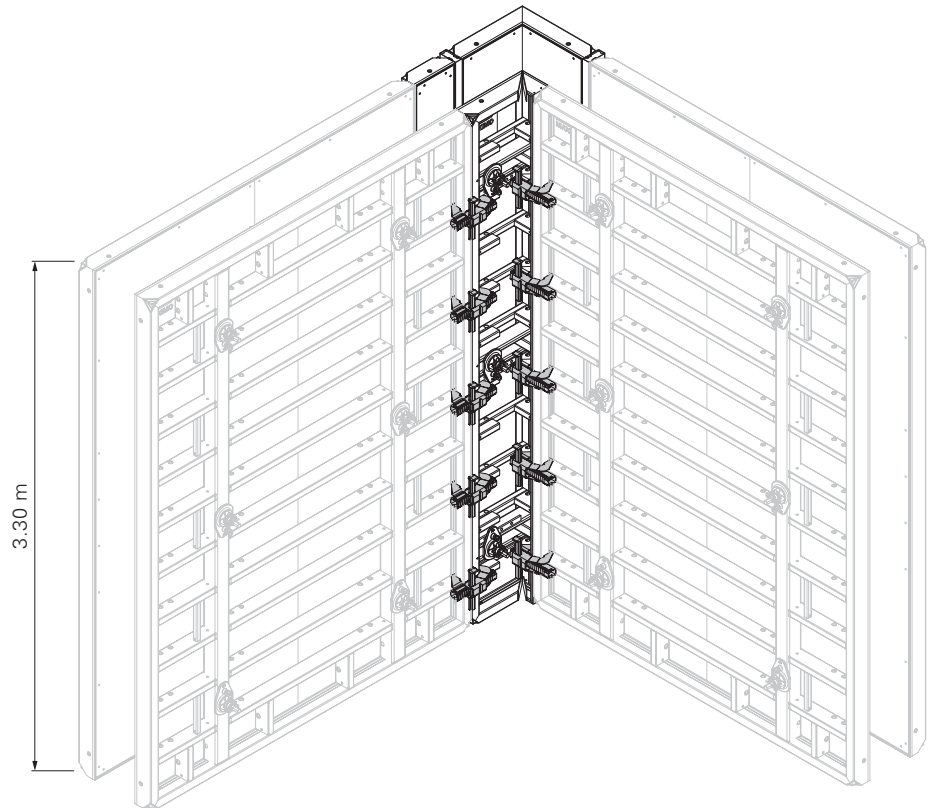

Fig. C1.05a

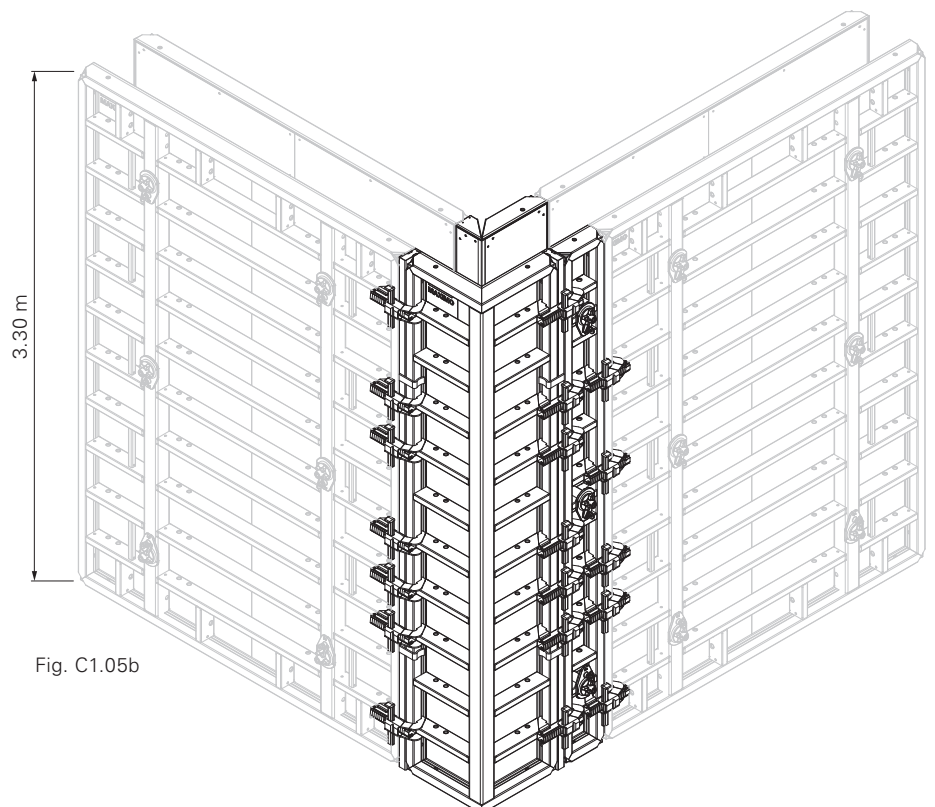

Fig. C1.05b

C1 90° Corners with Inside Corner MXI 18, 330 x 50/20

Wall Thicknesses > 40 – 60 cm

Outside Corner MXA 330 x 45



Perm. fresh concrete pressure: 60 kN/m²

Components

20	Alignment Coupler BFD
21	Compensation Waler MAR 85
22	Compensation Waler MAR 170
120	Panel MXM 18, 330 x 60
121	Panel MX 18, 330 x 30
122	Panel MX 18, 330 x 45
126	Panel MX 18, 330 x 240
142	Wall Thickness Compensator WDA MX 330 or filler timber supplied by contractor ≤ 10 cm
159	Outside Corner MXA 330 x 45
161	Inside Corner MXI 18, 330 x 50/20

Examples

- Wall thickness 45:
Fig. C1.10 + C1.10a + C1.10b
- Wall thickness 50:
Fig. C1.11 + C1.10a + C1.10b
- Wall thickness 55:
Fig. C1.12 + C1.12a + C1.12b
- Wall thickness 60:
Fig. C1.13 + C1.12a + C1.12b

Compensations

Wall thickness 45 + 50 + 60 cm:
external compensation.

Wall thickness 55 cm:
without compensation.

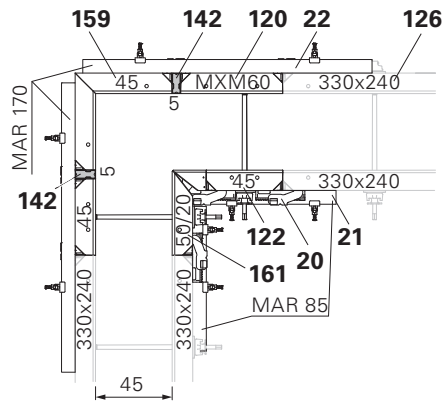

Fig. C1.10

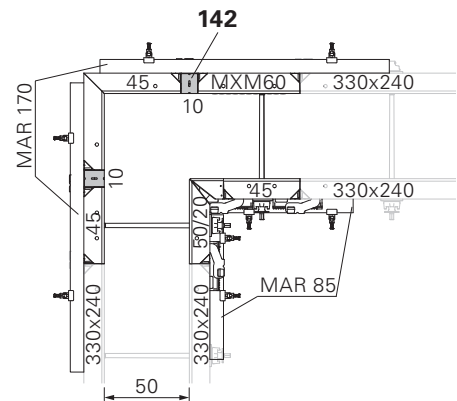

Fig. C1.11

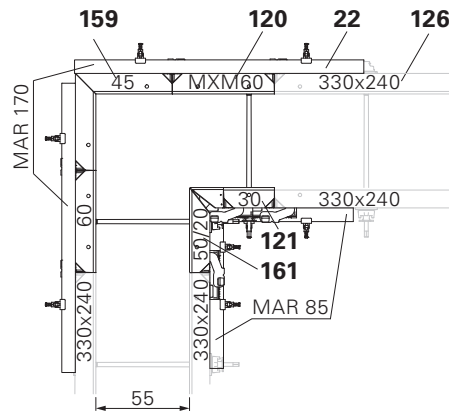

Fig. C1.12

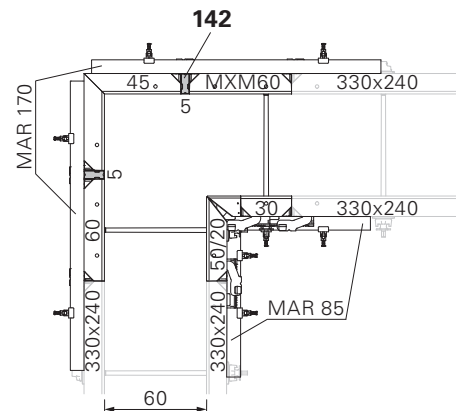

Fig. C1.13



- Offset mounting of BFD Alignment Couplers between
- Corner 50/20,
 - Panel ... x 30,
 - as well as following panel ... x 240.

„X“
from Fig. C1.12a

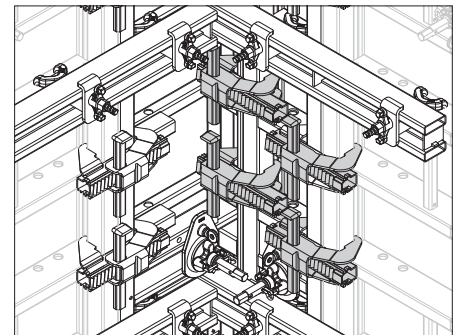

Fig. C1.12b

C1 90° Corners with Inside Corner MXI 18, 330 x 50/20

Arrangement of the Alignment Couplers and Compensation Walers

Valid for wall thicknesses > 40 – 50 cm.
(Fig. C1.10a + C1.10b)

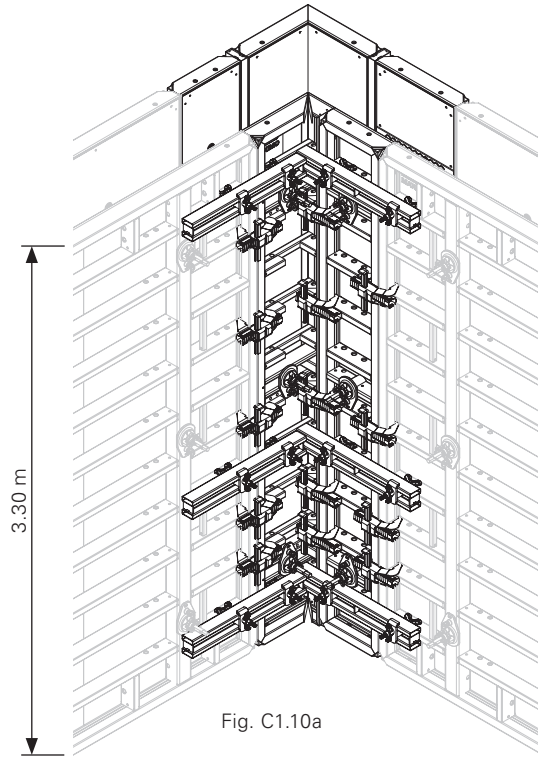

Fig. C1.10a

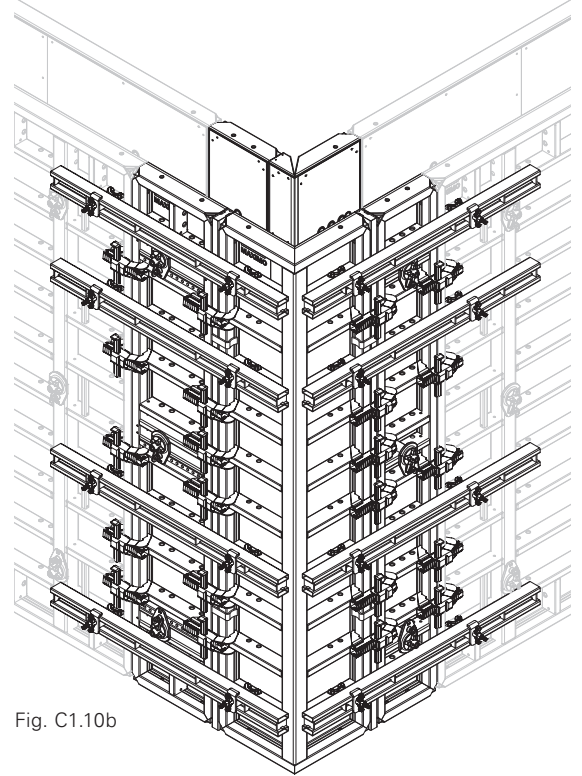

Fig. C1.10b

Valid for wall thicknesses > 50 – 60 cm.
(Fig. C1.12a + C1.12b)

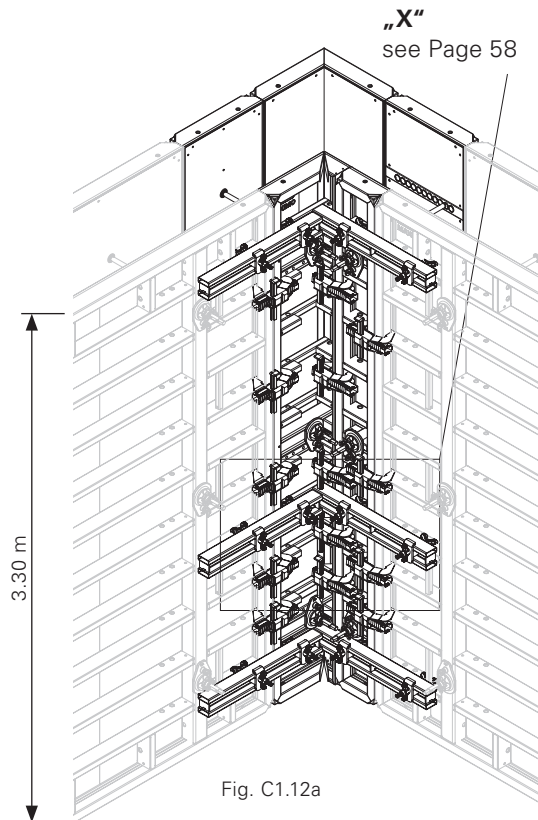

Fig. C1.12a

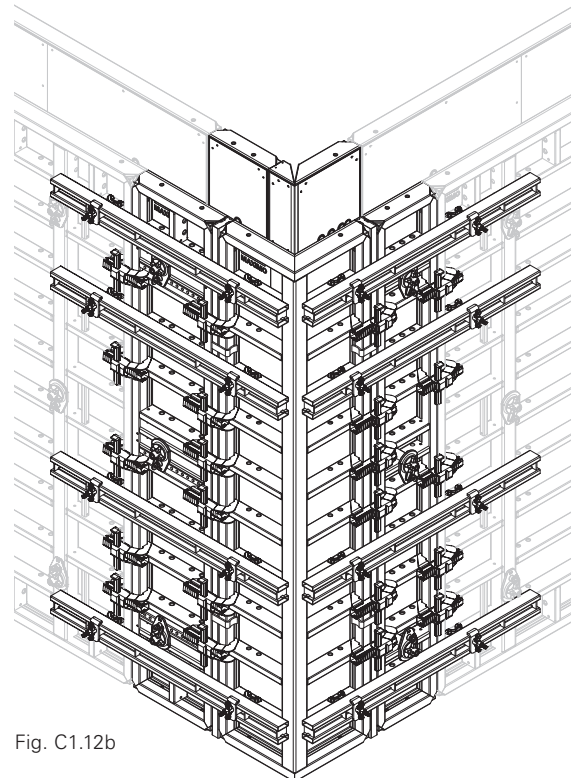

Fig. C1.12b

Panel connections

With 90° corners, these must be strengthened at the next panel joint by means of a Compensation Waler MAR 85 (21).

This applies to panels with widths $b \leq 120$.

With extensions, a second Compensation Waler MAR 85 is required on the panel joint.

(Fig. C2.01a + C2.01b)

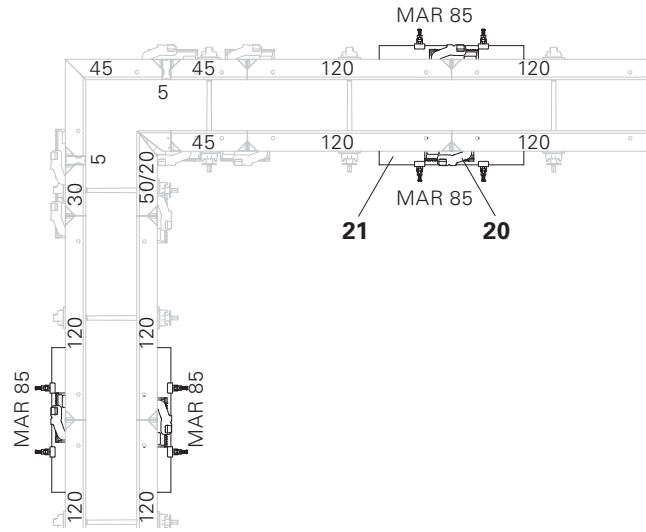

Fig. C2.01

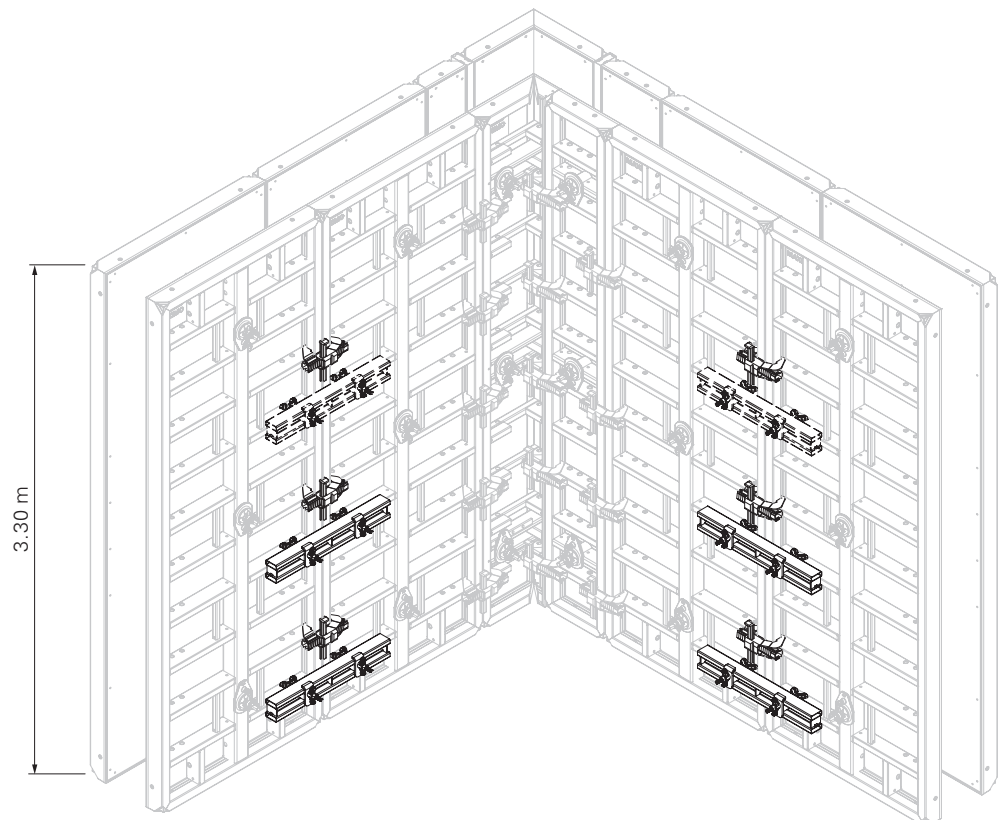

Fig. C2.01a

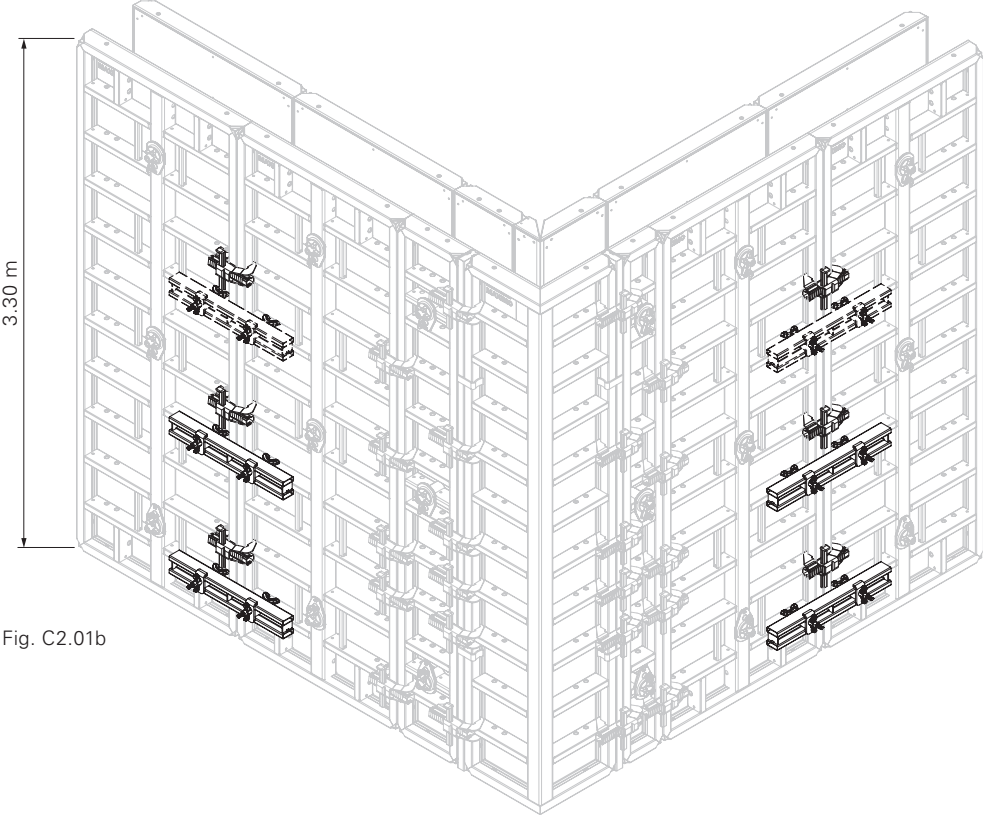

Fig. C2.01b

C3 90° T-junctions with Inside Corner MXI 18, 330 x 50/20

Wall Thicknesses 15 – 40 cm



Perm. fresh concrete pressure: 80 kN/m²

Components

20	Alignment Coupler BFD
120	Panel MXM 18, 330 x 60
122	Panel MX 18, 330 x 45
123	Panel MX 18, 330 x 60
126	Panel MX 18, 330 x 240
142	Wall Thickness Compensator WDA MX 330 or filler timber supplied by contractor ≤ 10 cm
161	Inside Corner MXI 18, 330 x 50/20

Assembly

1. Form the T-junction with Inside Corner MXI 50/20 18, (161).
2. Form the opposing straight wall with Panel MX 18, 45 (122), MX 18, 60 (123) or MXM 18, 60 (120) depending on the wall thickness.
3. Install compensation (142) in accordance with the wall thickness.

Examples

- Wall thickness 15:
Fig. C3.01 + C3.05a + C3.05b
- Wall thickness 17.5:
Fig. C3.02 + C3.05a + C3.05b
- Wall thickness 20:
Fig. C3.03 + C3.05a + C3.05b
- Wall thickness 24 / 25:
Fig. C3.04 + C3.05a + C3.05b
- Wall thickness 30:
Fig. C3.05 + C3.05a + C3.05b
- Wall thickness 35 / 36:
Fig. C3.06 + C3.05a + C3.05b
- Wall thickness 40:
Fig. C3.07 + C3.05a + C3.05b

Compensations

- Wall thickness 15 + 17.5 + 24 + 25 cm:
external compensation
- Wall thickness 30 + 35 + 36 + 40 cm:
external compensation
- Wall thickness 20:
without compensation



90° T-junctions with Inside Corner MXI 18, ... x 60, see D3.

Alternatively - panel width 45

Max. panel width on the T-junction between corner and following panel is 45 cm – MX 18, 330 x 45 (122). (Fig. C3.08)

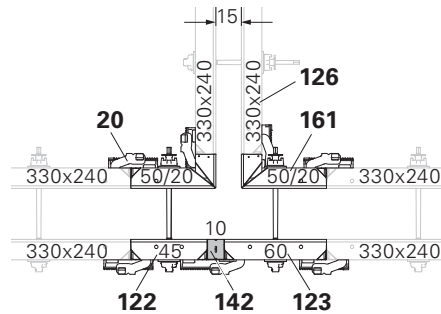

Fig. C3.01

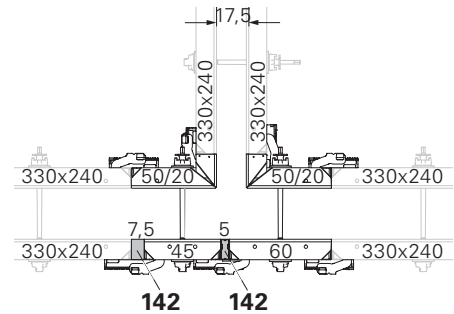

Fig. C3.02

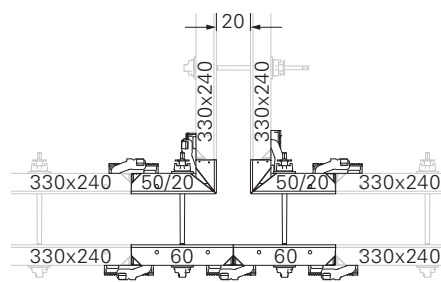

Fig. C3.03

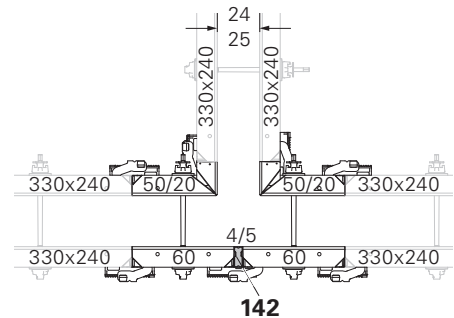

Fig. C3.04

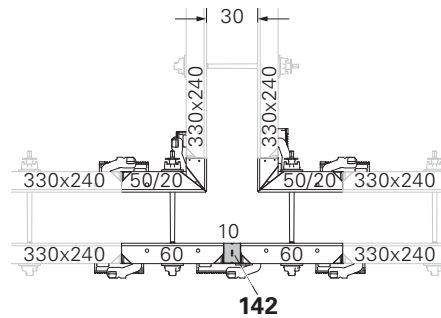

Fig. C3.05

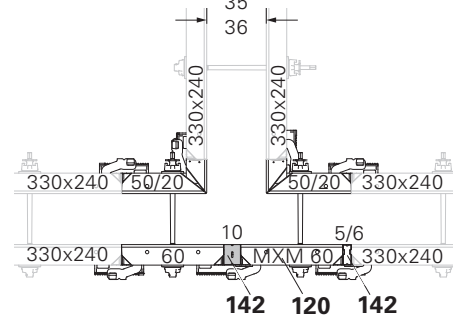

Fig. C3.06

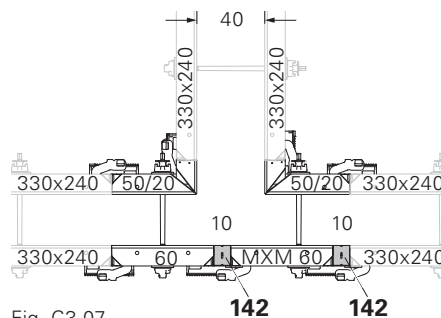

Fig. C3.07

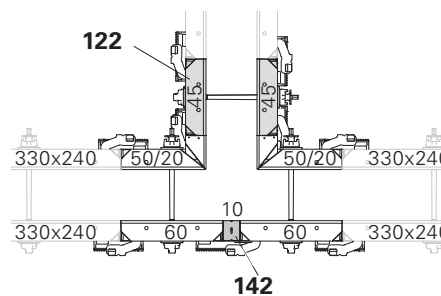

Fig. C3.08

C3 90° T-junctions with Inside Corner MXI 18, 330 x 50/20

Arrangement of the Alignment Couplers

Valid for wall thicknesses 15 – 45 cm.
(Fig. C3.05a + C3.05b)

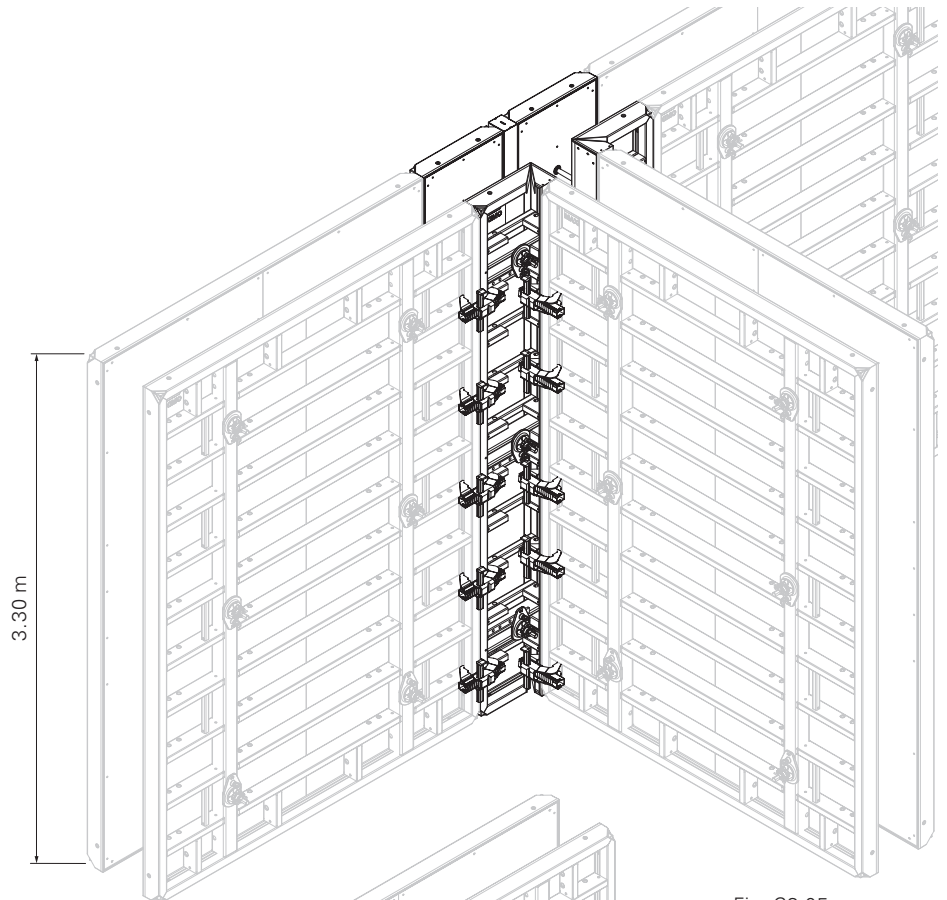

Fig. C3.05a

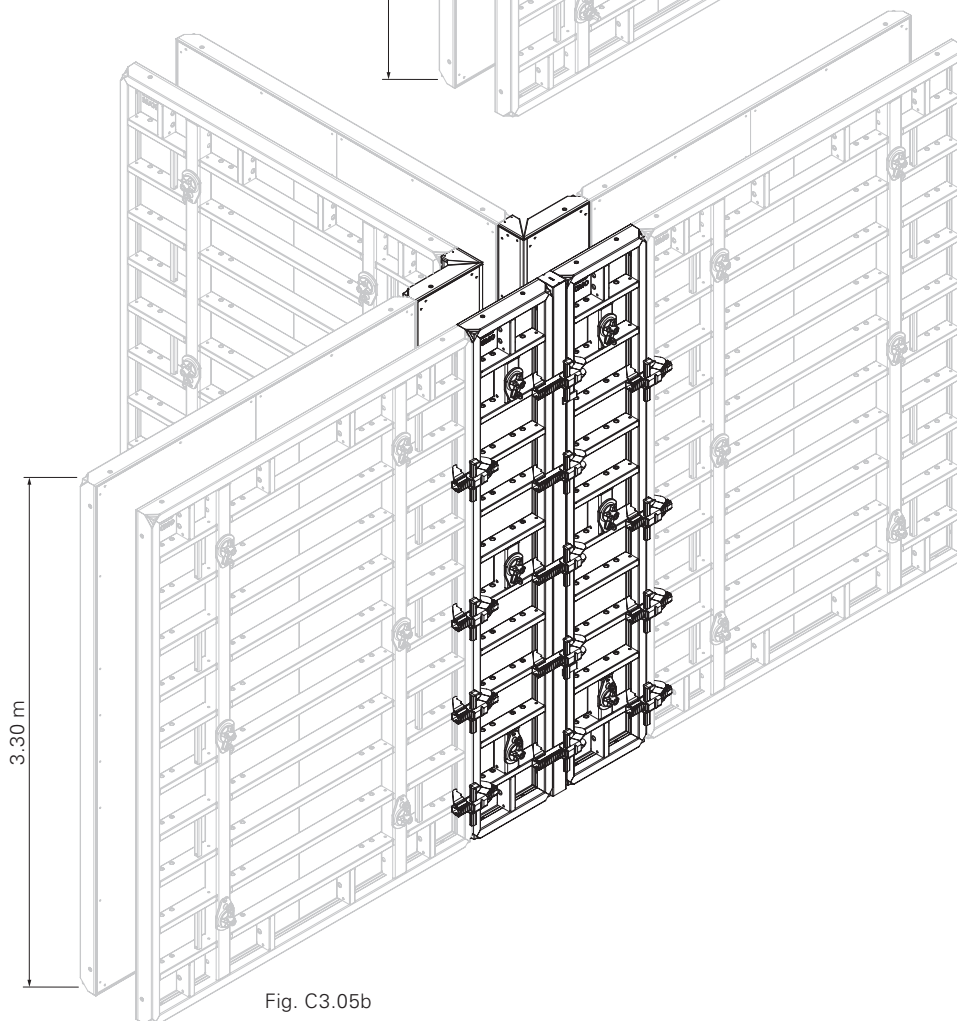

Fig. C3.05b

C3 90° T-junctions with Inside Corner MXI 18, 330 x 50/20

Wall Thicknesses > 40 – 60 cm



Perm. fresh concrete pressure: 60 kN/m²

Components

20	Alignment Coupler BFD
22	Compensation Waler MAR 170
120	Panel MXM 18, 330 x 60
122	Panel MX 18, 330 x 45
123	Panel MX 18, 330 x 60
126	Panel MX 18, 330 x 240
142	Wall Thickness Compensator WDA MX 330 or filler timber supplied by contractor ≤ 10 cm
161	Inside Corner MXI 18, 330 x 50/20

Assembly

1. Form the T-junction with Inside Corner MXI 18, 50/20 (161).
2. Form the opposing straight wall with Panel MX 18, 45 (122), MX 18, 60 (123) or MXM 18, 60 (120) depending on the wall thickness.
3. Install compensation (142) in accordance with the wall thickness.
4. On the straight wall, install Compensation Waler MAR 170 (22) centrally to the outgoing wall.

Examples

Wall thickness 45:

Fig. C3.09 + C3.09a + C3.09b

Wall thickness 50:

Fig. C3.10 + C3.09a + C3.09b

Wall thickness 55:

Fig. C3.11 + C3.09a + C3.09b

Wall thickness 60:

Fig. C3.12 + C3.09a + C3.09b

Compensations

Wall thickness 45 + 55 + 60 cm:
external compensation

Wall thickness 50:

without compensation



90° T-junctions with Inside Corner MXI 18, ... x 60, see Section D3.

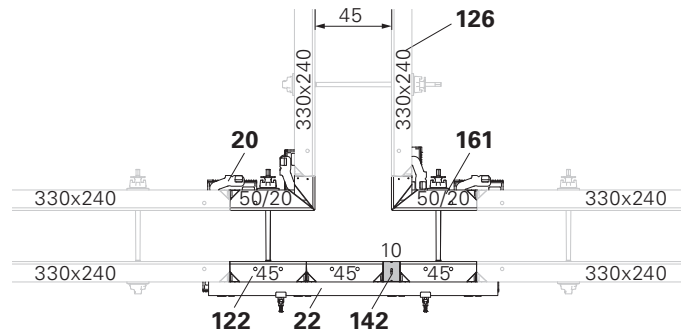

Fig. C3.09

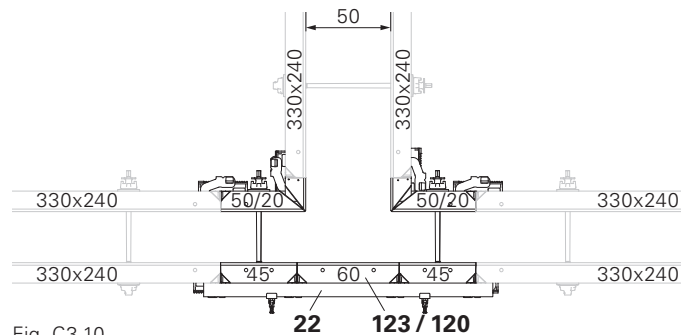

Fig. C3.10

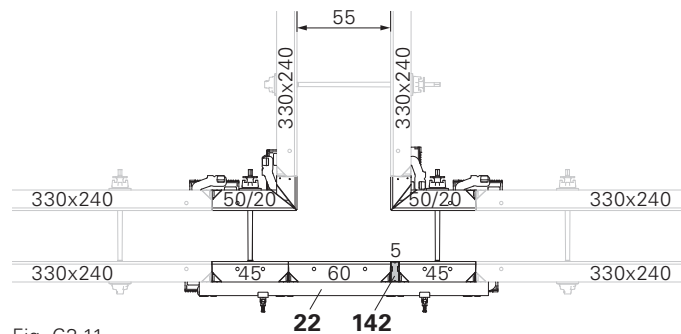

Fig. C3.11

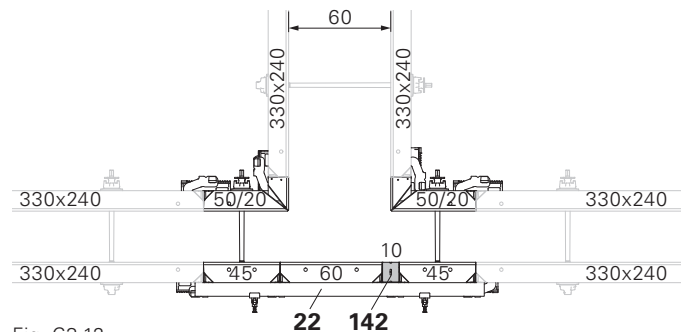

Fig. C3.12

C3 90° T-junctions with Inside Corner MXI 18, 330 x 50/20

Arrangement of the Alignment Couplers and Compensation Walers

Valid for wall thicknesses > 40 – 60 cm.
(Fig. C3.09a + C3.09b)

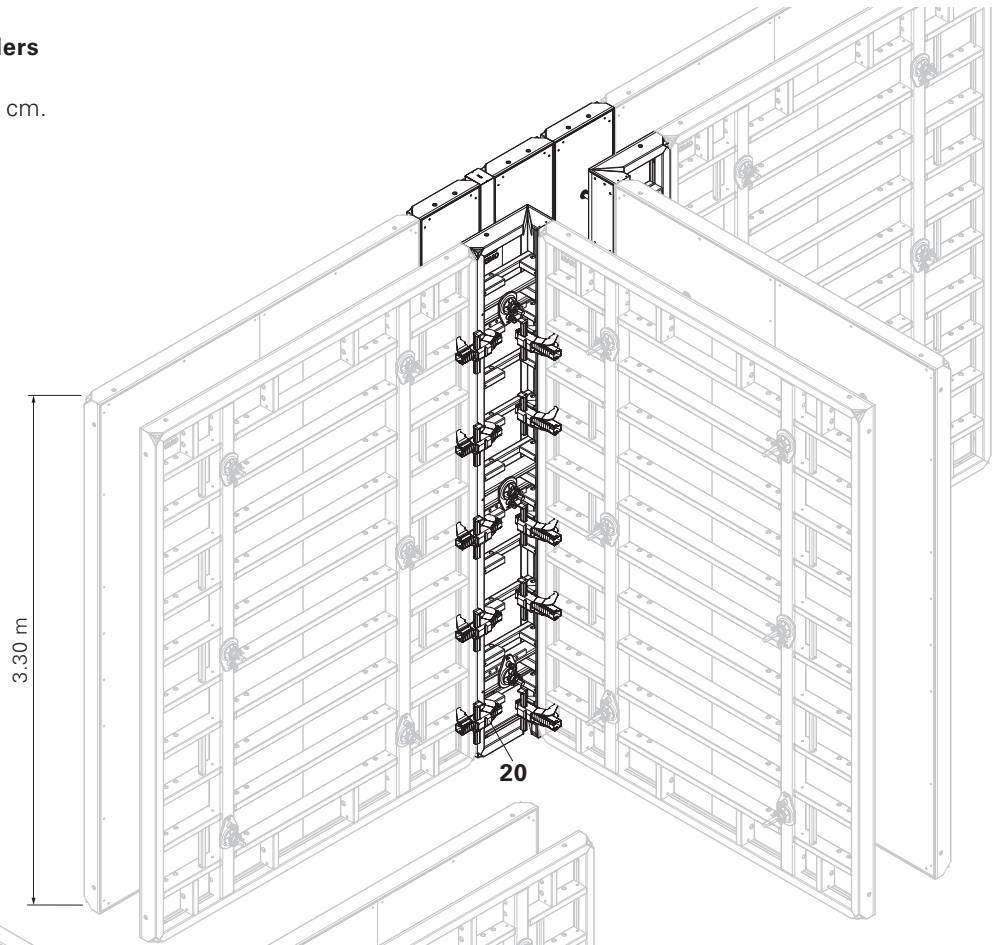

Fig. C3.09a

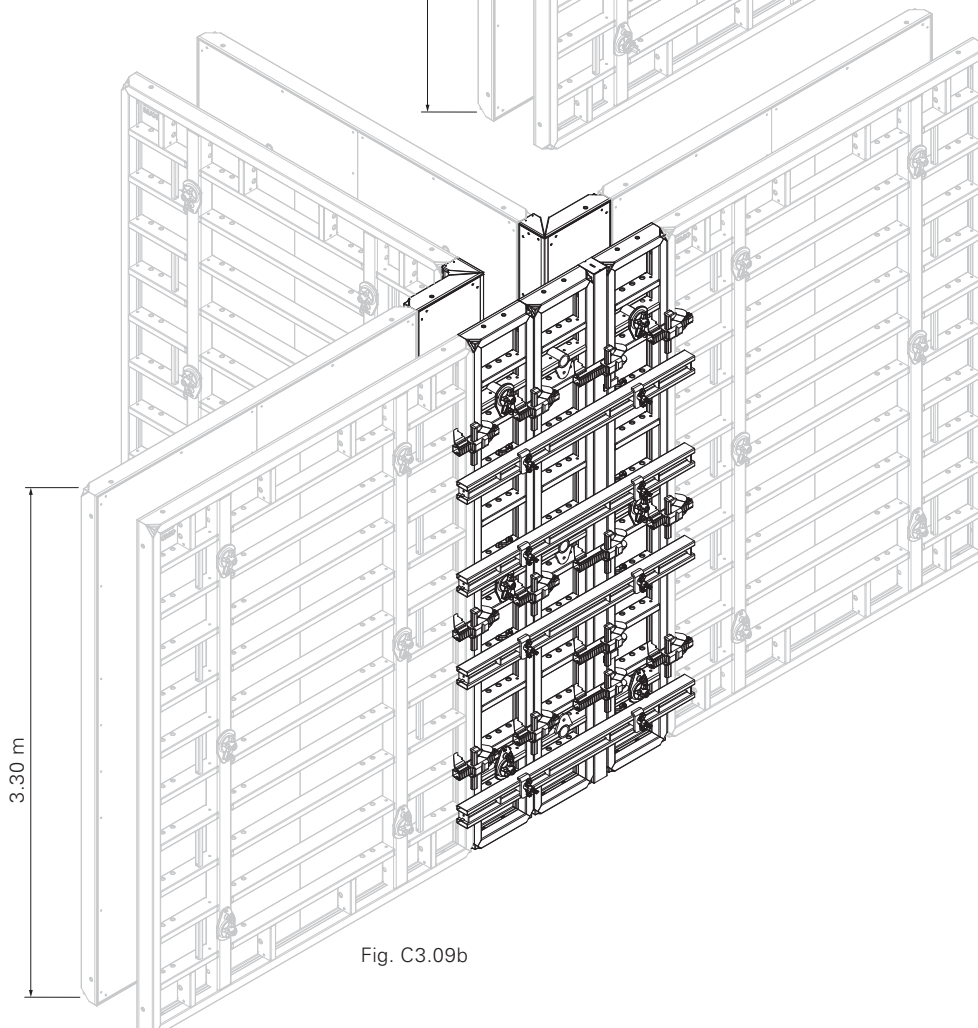

Fig. C3.09b

C4 Panel Connections following 90° T-junctions

Panel connections

With 90° T-junctions, these must be strengthened at the next panel joint by means of a Compensation Waler MAR 85 (21).

This applies to panels with widths $b \leq 120$.

With extensions, a second Compensation Waler MAR 85 is required on the panel joint (shown as a dotted line).

(Fig. C4.01)

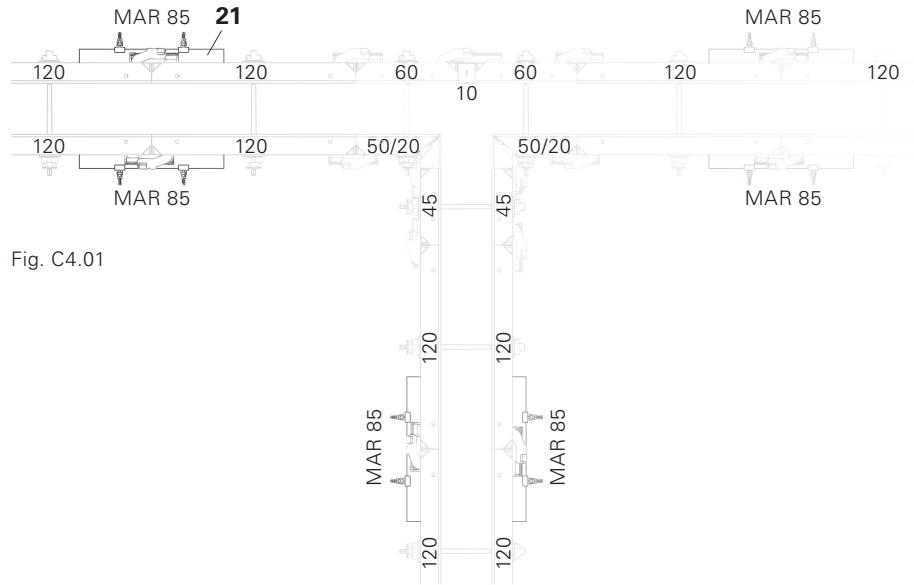

Fig. C4.01

Arrangement of the Alignment Couplers and Compensation Walers

(Fig. C4.01a + C4.01b)

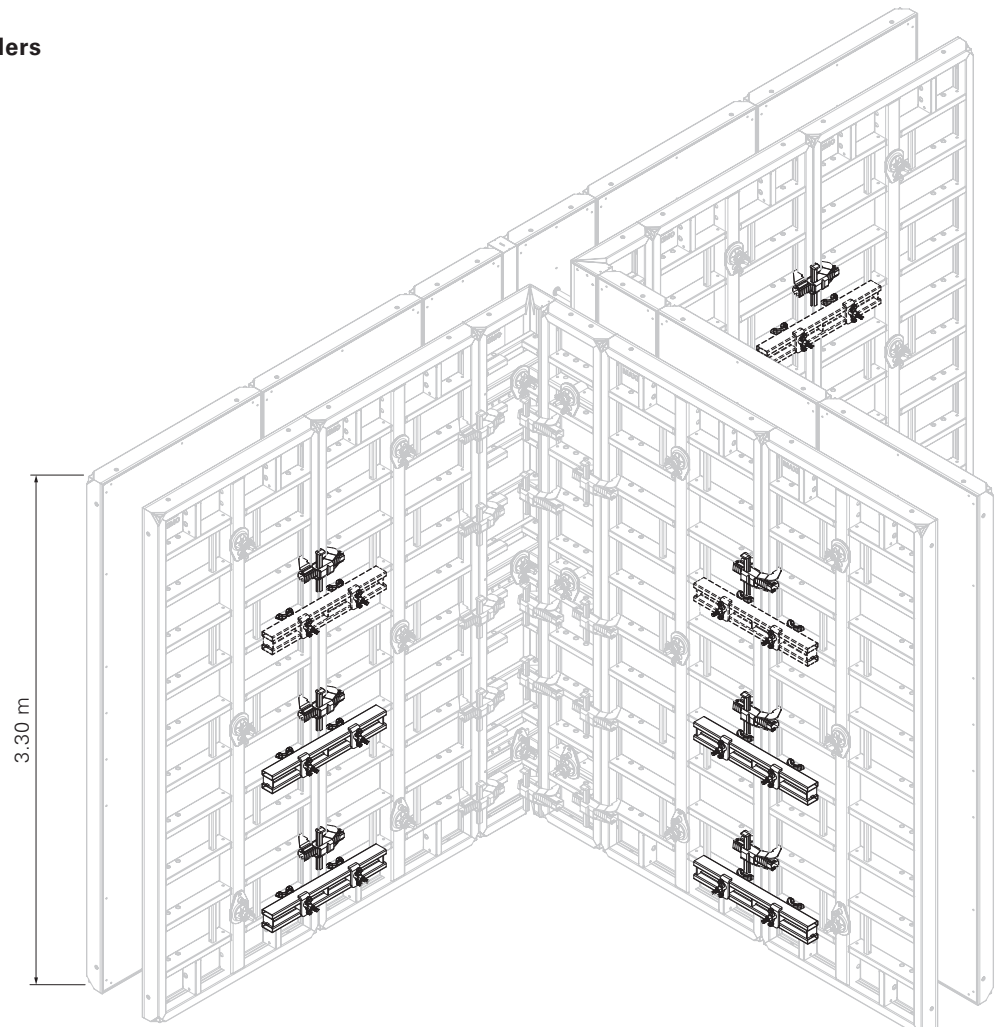

Fig. C4.01a

C4 Panel Connections following 90° T-junctions



Fig. C4.01b

Tension and Compression Brace MX 15-40 / MX 15-100

With a panel height of 3.30 m, the top tie is not required if a Tension and Compression Brace MX 15-40 or MX 15-100 is used.

The panel is braced through the Tension and Compression Brace (70).



Panel height 330 cm:
setting dimension = wall thickness.

Preparation and assembly of the Tension and Compression Brace, see Section A9.

Close open tie holes on the form-lining by means of Plugs MXM 18, Item no. 125099.



Always mount platforms and brackets on the side of the securing hook (70.1) – here the closing formwork.

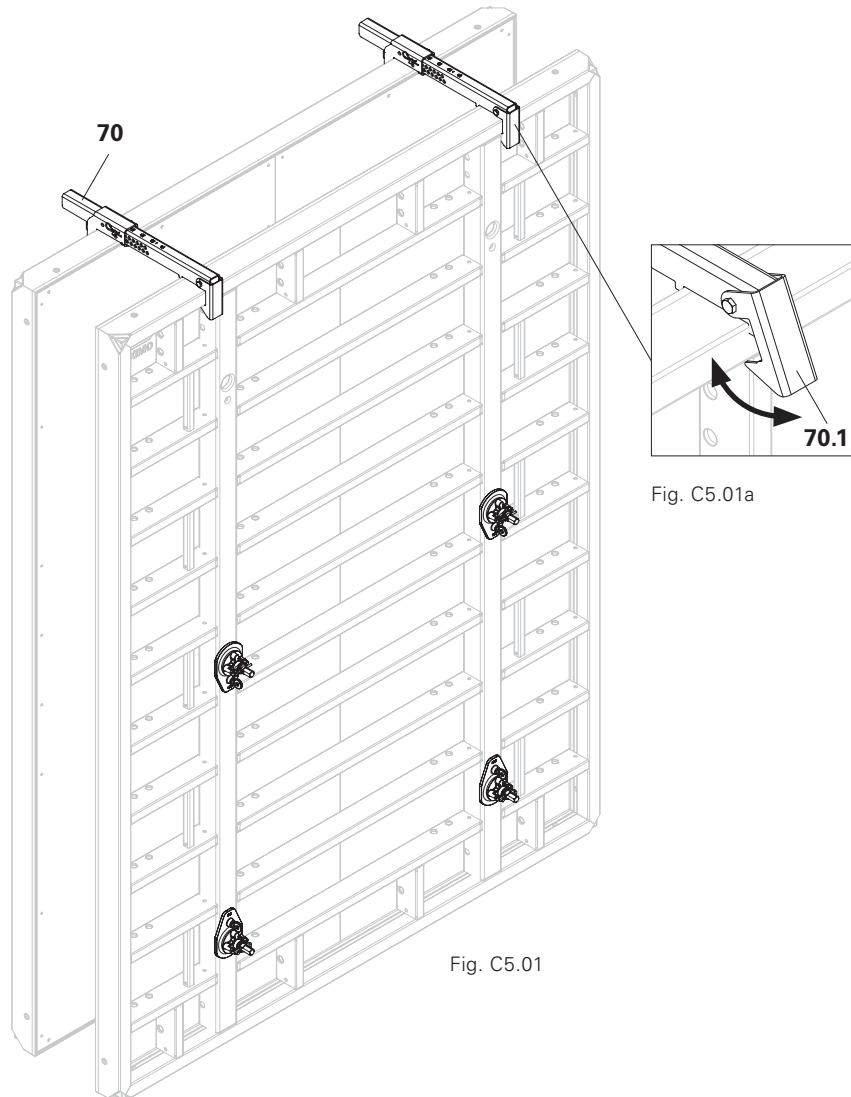

Fig. C5.01a

Fig. C5.01

Wall Thickness Compensator WDA MX 330

Length compensation up to 10 cm.

Components

20	Alignment Coupler BFD	4x
50	WDA MX 330 x ... or timber	1x



No ties required!

The length is compensated with Wall Thickness Compensator MX or using timber which has been cut to size (50).
Note: number and arrangement of the BFD Alignment Couplers (20).
(Fig. C6.01)

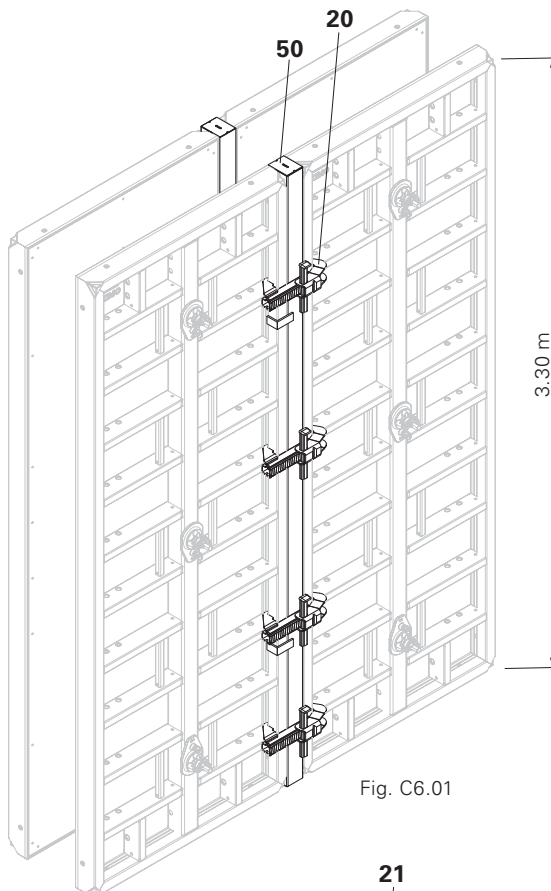

Fig. C6.01

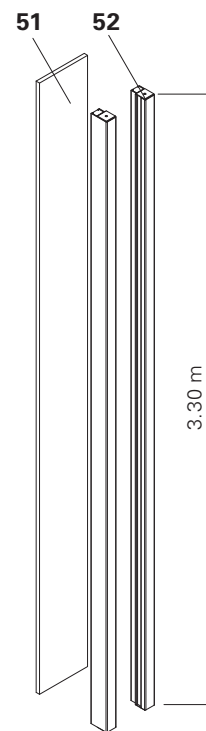

Fig. C5.02a

Filler Profile TPP

Length compensation from 20 to 36 cm.



- Perm. fresh concrete pressure:
80 kN/m² for: $b \geq 20$ and $b < 30$ mm.
- Perm. fresh concrete pressure:
60 kN/m² for: $b \geq 30$ and $b \leq 36$ mm.

Components

20	Alignment Coupler BFD	6x
21	Compensation Waler MAR 85	3x
51	Plywood filler 21 mm	1x
52	Filler Profile TPP	2x

When anchoring, ensure that the tie forces are transferred centrally through the Compensation Waler MAR 85 (21) to the adjacent panels.
(Fig. C6.02b)

Installation (Fig. C6.02 + C6.02a)

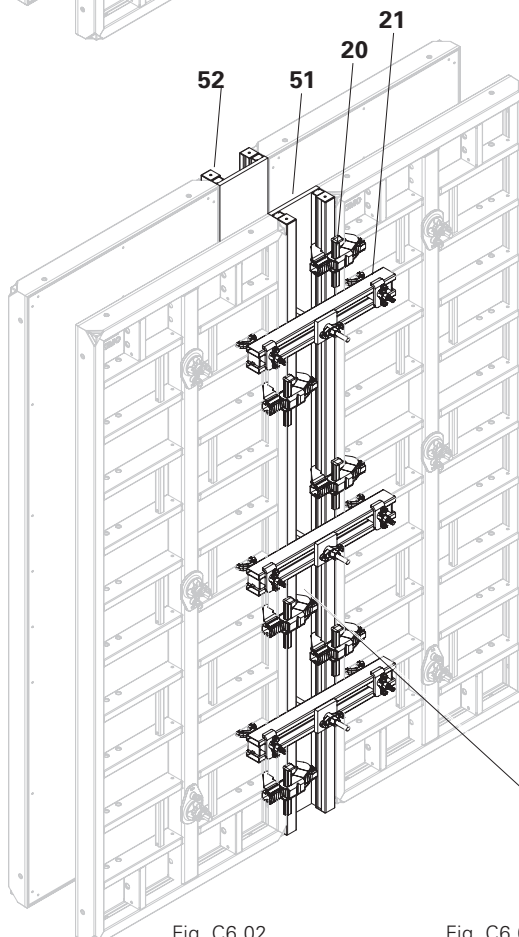

Fig. C6.02

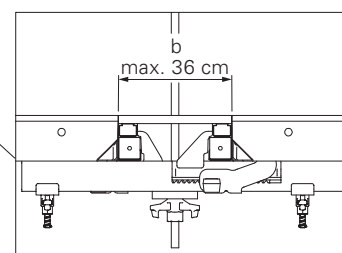

Fig. C6.02b

Stopend Formwork with Panel MX 18, 330 x 30

As Stopend Panel (121) for 30 cm wall thickness.
(Fig. C7.01)

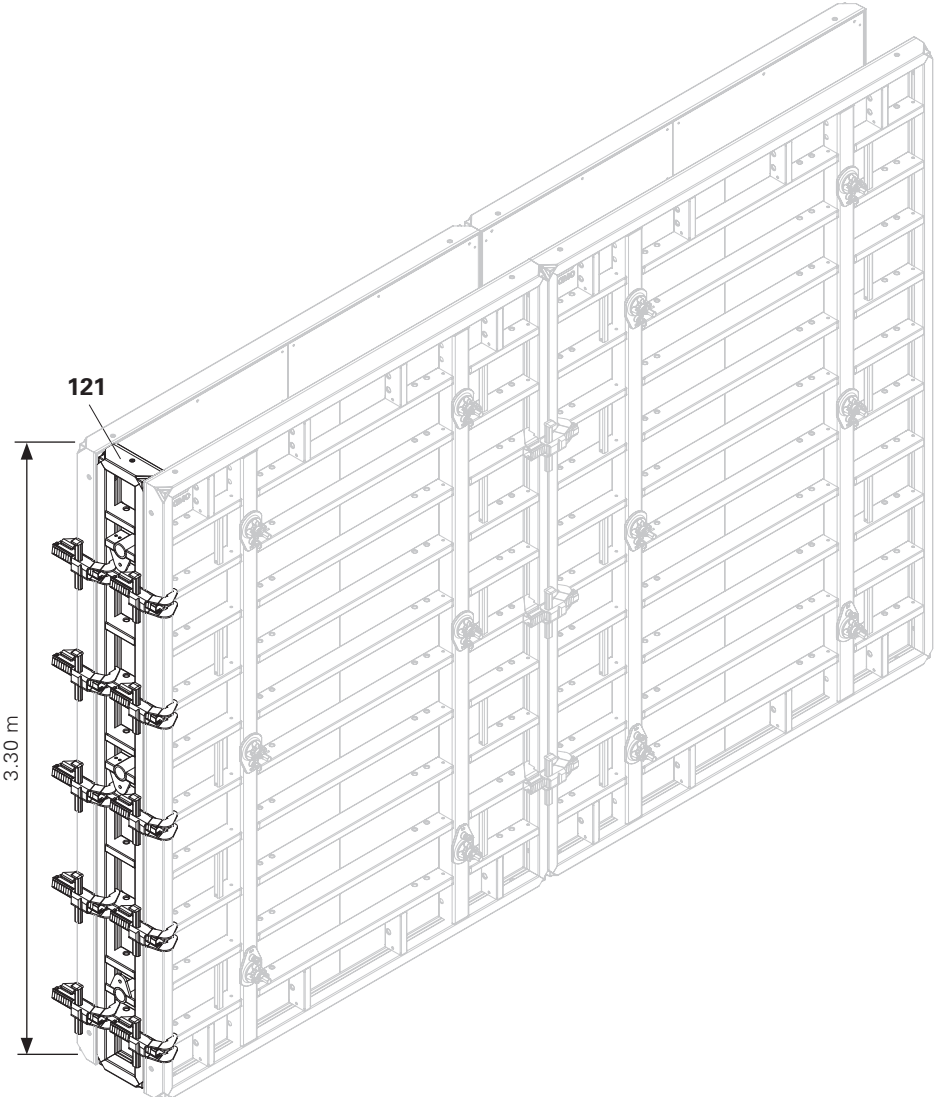

Fig. C7.01

Stopend Formwork with timber and filler plywood

For walls of any thickness.



The fresh concrete pressure of the stopend formwork is transferred to the MAXIMO Panels via the stopend ties and Waler 85.

With Panel MX 18, 330 x 120 at the end of the wall.

(Fig. C7.02 + C7.03)

Also valid for the following panels:

- MXI MX 18, 330 x 30
- MXI MX 18, 330 x 45
- MXI MX 18, 330 x 60
- MXI MX 18, 330 x 90

Connecting parts

21 Compensation Waler MAR 85 / alternatively: Waler 85	4x
23 Wingnut Pivot Plate DW 15	14x
25 Tie Rod DW 15	3x
26 Timber	2x
27 Top Tie Bracket-2 AH	6x
28 Stopend Tie TS	8x
51 Plywood filler 21 mm	1x

- Compensation Waler MAR 85 (21) with Stopend Tie (28) and Wingnut Pivot Plate (23), see Fig. C7.03b.
- Top Tie Bracket-2 AH with Tie Rod (25) and Wingnut Pivot Plate (23), see Fig. C7.03a.

With Panel MX 18, 330 x 240 at the end of the wall.

(not shown)

Connecting parts

21 Compensation Waler MAR 85 / alternatively: Waler 85	4x
23 Wingnut Pivot Plate DW 15	8x
26 Timber	2x
28 Stopend Tie TS	8x
51 Plywood filler 21 mm	1x

Compensation Waler MAR 85 (21) with Stopend Tie (28) and Wingnut Pivot Plate (23), see Fig. B6.03b.

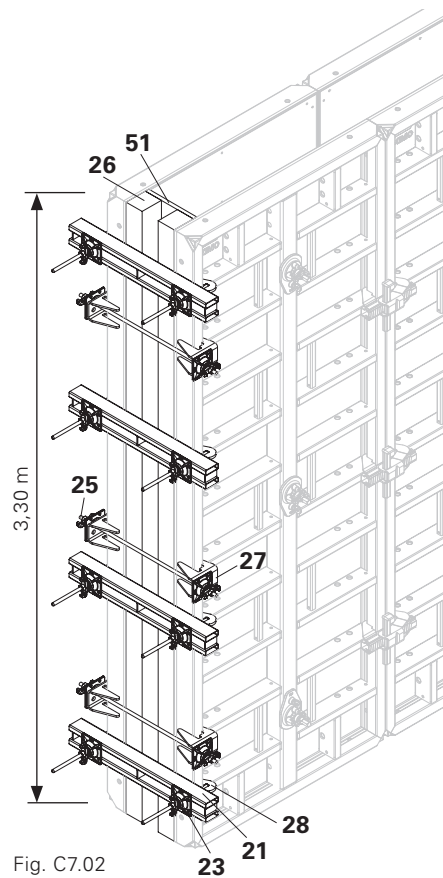

Fig. C7.02

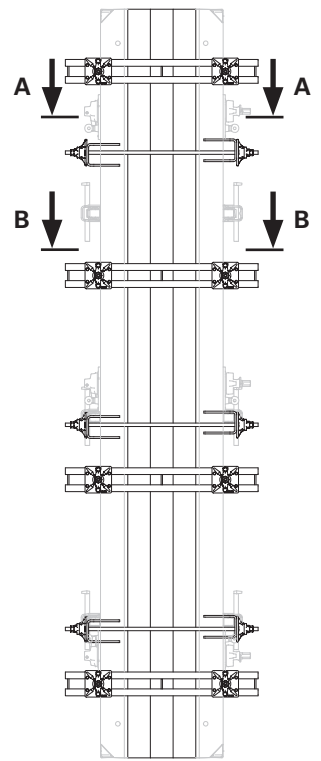

Fig. C7.03

A - A

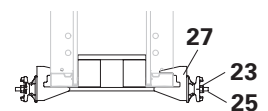

Fig. C7.03a

B - B

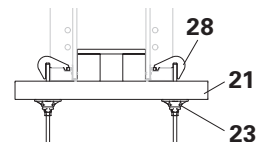

Fig. C7.03b

Extension Guidelines

Horizontal pre-assembly
up to H = 6.60 m



Swivel nuts of the tie points must be mounted on the primary formwork!

Panel connections

For height extension units

- H < 6.60 m, Alignment Couplers BFD (20) are to be used on the panel joints. (Fig. C8.01c)
- H = 6.60 m, Alignment Couplers BFD (20) and Compensation Walers MAR 85 (21) are to be used on the panel joints. (Fig. C8.01a + C8.01b)

Assembly

1. The assembly surface must be level.
2. Place timbers or planks in position as support.
3. Pre-assemble extension units in a horizontal position, with the form-lining facing downwards.

MX 18, 330 x
60 / 90 / 120

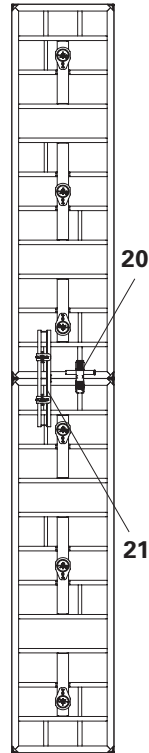

Fig. C8.01a

MX 18, 330 x 240

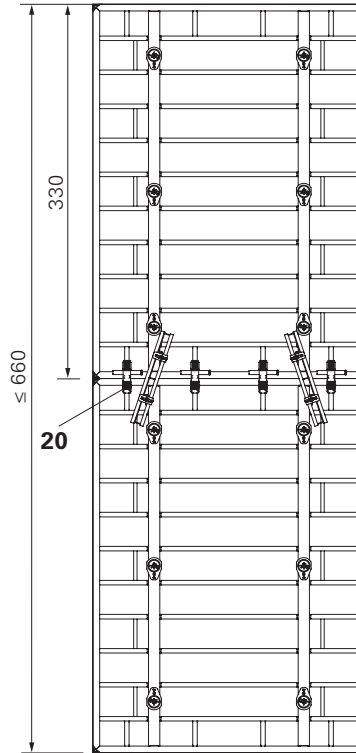

Fig. C8.01b

MX 18, 330 x 240

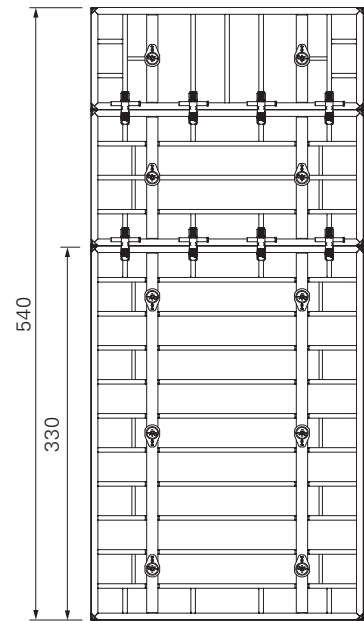

Fig. C8.01c

Erection with the crane

(Fig. C8.02)



- Do not exceed the permissible load-bearing capacity of the MAXIMO Lifting Hook and crane!
- Note: Instructions for Use for the MAXIMO Lifting Hook 1.5 t!

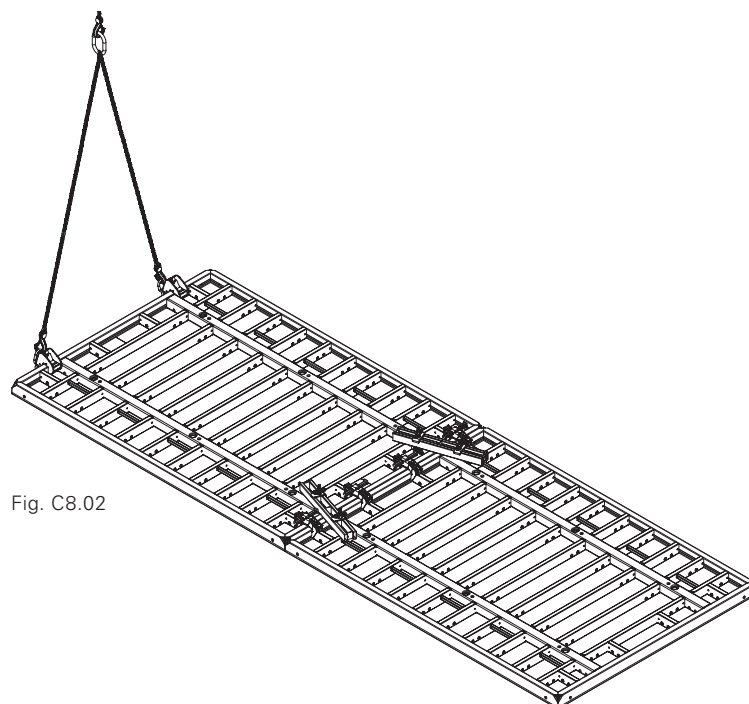

Fig. C8.02

Extension Guidelines

Horizontal pre-assembly
up to $H = 7.20$ m



Swivel nuts of the tie points must be mounted on the primary formwork!

Panel connections

For extension units $H > 6.00$ m and $H \leq 7.20$ m, Alignment Couplers BFD (20) and Compensation Walers MAR 85 (21) are to be used on panel joints. (Fig. C8.03a + C8.03b)

Assembly

1. The assembly surface must be level.
2. Place timbers or planks in position as support.
3. Pre-assemble extension units in a horizontal position, with the form-lining facing downwards.

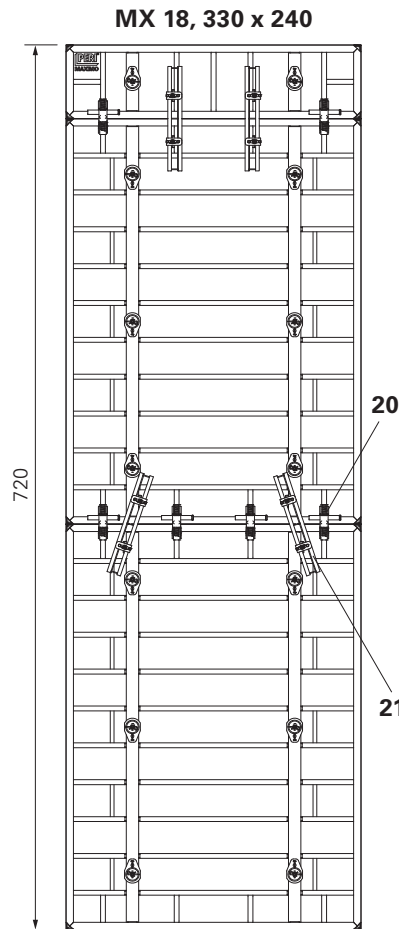

Fig. C8.03a

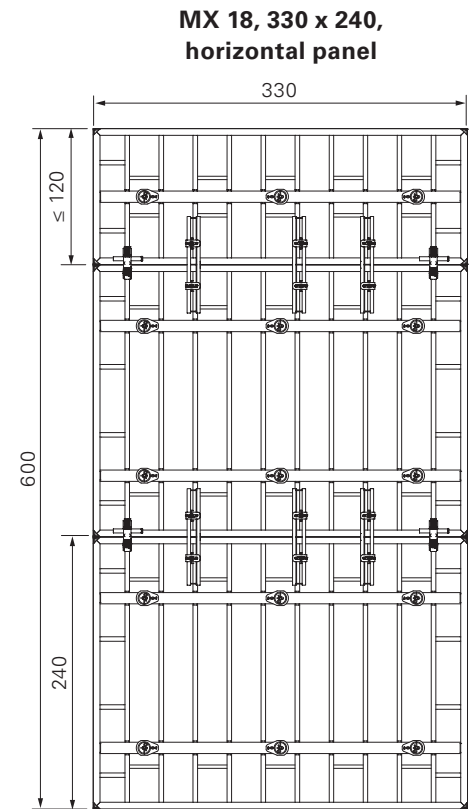

Fig. C8.03b

Erection with the crane

(Fig. C8.04)



- Do not exceed the permissible load-bearing capacity of the MAXIMO Lifting Hook and crane!
- Note: Instructions for Use for the MAXIMO Lifting Hook 1.5 t!

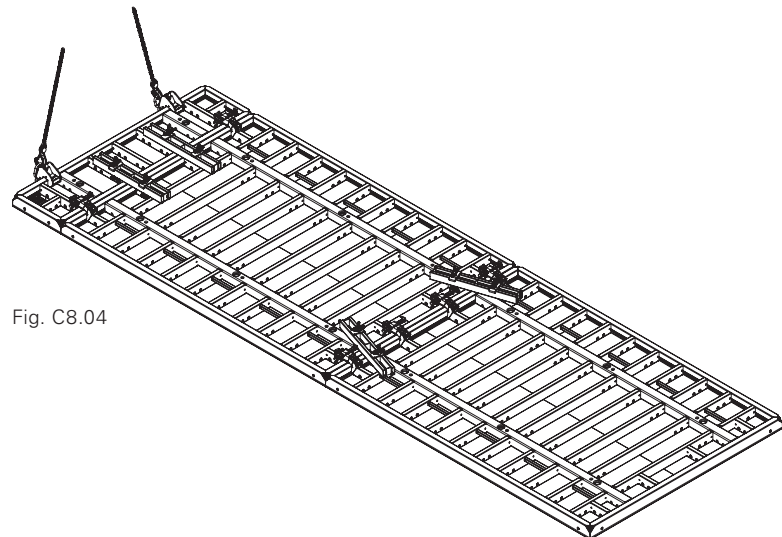

Fig. C8.04

Magnet Cone MX 18

Item no. 127696 (Fig. D1.01)



When using the Magnet Cone MX 18, the inclined position of the tie is reduced to 2.5°.

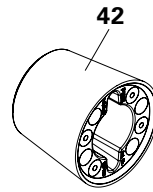

Fig. D1.01

Installation



Before installing the Magnet Cone MX 18, ensure that

- the magnetic cone was completely submerged in a release agent and has been allowed to drain off, and
- the contact surfaces of the magnet are clean.

The Magnet Cone MX 18 (42)

- can be used on one side or on both sides without a spacer tube,
- is held in position at the tie point with magnets.

Installation on one side

(Fig. D1.02a)

Installation on both sides

(Fig. D1.02b)

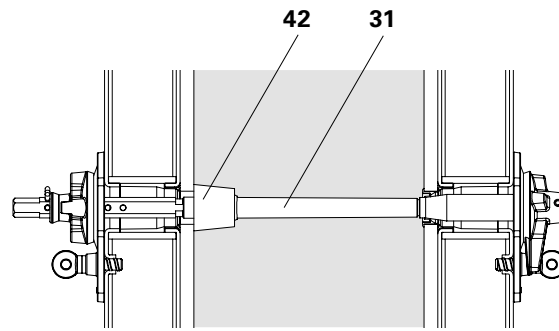

Fig. D1.02a

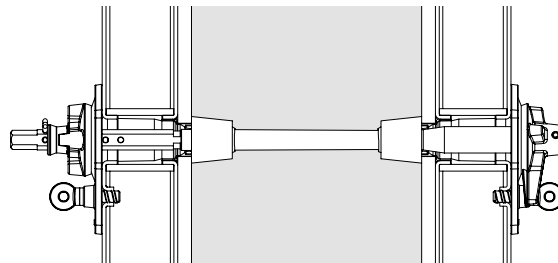

Fig. D1.02b

Removal



- Remove concrete slurry in the Magnet Cone – shortly after striking.
- Remove by means of Magnet Cone Spanner MX 15/18 (43), Item no. 126696. (Fig. D1.03)

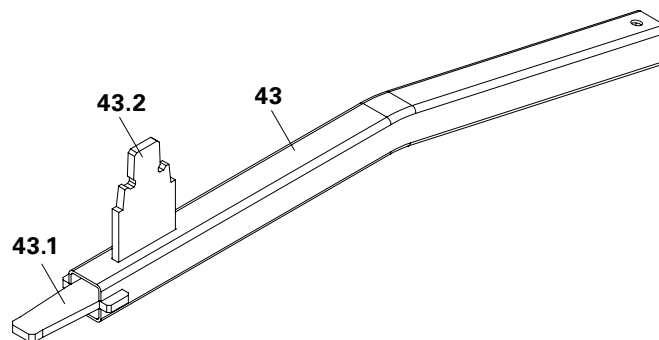

Fig. D1.03

Dismantling

1. Clean hole using the pointed side of the wrench (43.1). Not shown.
2. Insert pointed side of wrench (43.1) into the guide groove of the Magnet Cone from the right, and clean the slot. (Fig. D1.04a)
3. Insert pointed side of wrench (43.1) into the guide groove of the Magnet Cone from the left, and clean the slot. (Fig. D1.04b)

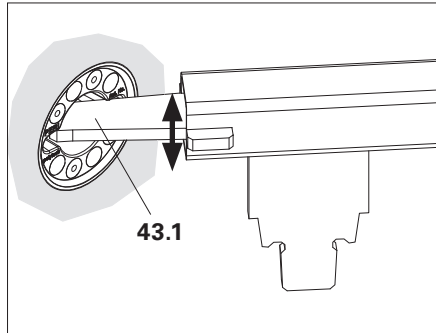

Fig. D1.04a

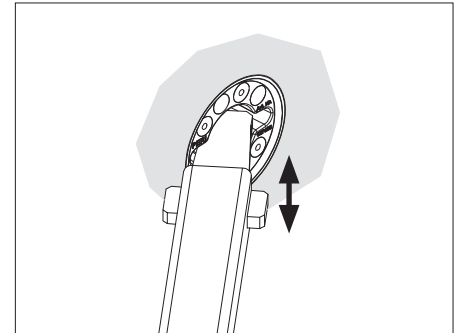

Fig. D1.04b

→ Hole and guide grooves of the Magnet Cone are free of concrete slurry.

4. Insert tube supports with wings (43.2) into the cleaned openings. (Fig. D1.04c)
5. Turn the Magnet Cone Spanner. (Fig. D1.04d)
→ Magnet Cone MX 18 is screwed out.

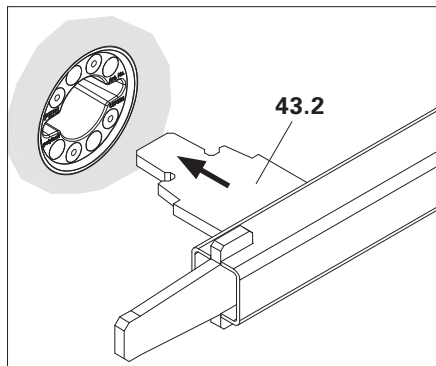

Fig. D1.04c

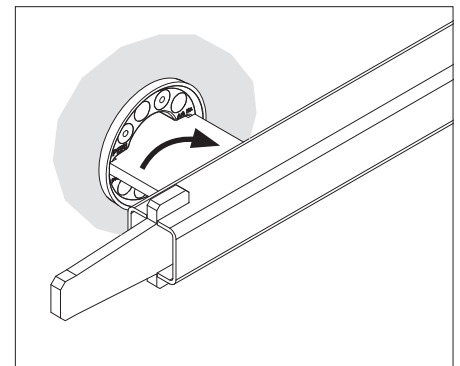

Fig. D1.04d

Closing the cone openings

PERI “DK / SK System” Tie Technology can be used for special requirements such as architectural concrete or waterproof walls – see “PERI Tie Technology” brochure.



Follow the Instructions of Use for concreting cones and the safety data sheet for sealing compounds.

Assembly

1. Apply prepared sealing compound or Repoxal to front conical part of the Concreting Cone.
2. Insert Concreting Cone into the tie hole.
→ Tie hole is closed.

Examples

- Smooth surface with DK Concrete Cone UNI 58/52, Item no. 031643.
- Sealing Compound, Item no. 108136. (Fig. D1.05)

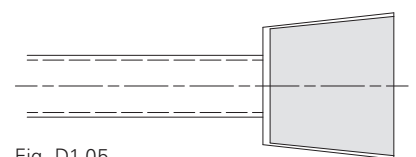

Fig. D1.05

- Recessed surface with DK Concrete Cone DW 15/58-30, Item No. 031550.
- Repoxal, Item no. 108136. (Fig. D1.06)

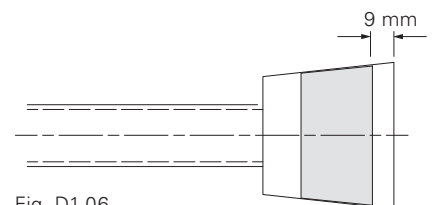

Fig. D1.06

- Shadow joint with DK Concrete Cone Architectural Concrete DW 15/58-52, Item no. 031641.
- Sealing Compound, Item no. 108136. (Fig. D1.07)

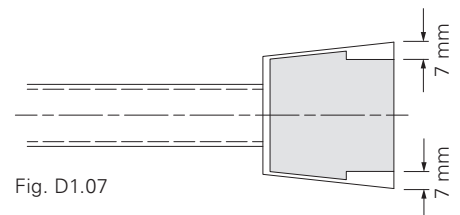

Fig. D1.07

D2 90° Corners with Inside Corner MXI 18, 270/330 x 60

Wall Thicknesses 15 – 30 cm
Height (H) 2.70 m or 3.30 m

Outside Corner MXA 270/330 x 35



Perm. fresh concrete pressure: 80 kN/m²

Components

20	Alignment Coupler BFD
101/121	Panel MX 18, 270/330 x 30
106/126	Panel MX 18, 270/330 x 240
140/142	Wall Thickness Compensator WDA MX or filler timber supplied by contractor ≤ 10 cm
150/158	Outside Corner MXA 270/330 x 35
152/160	Inside Corner MXI 18, 270/330 x 60

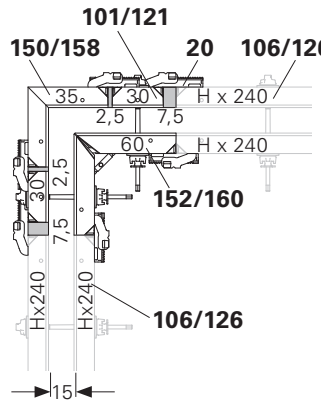

Fig. D2.01

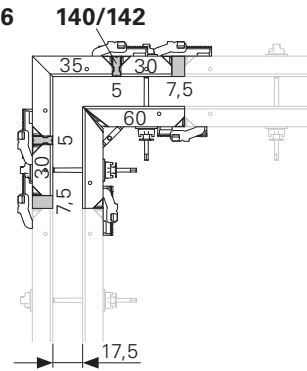

Fig. D2.02

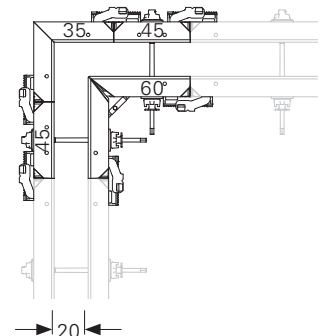

Fig. D2.03

Examples

- Wall thickness 15:
Fig. D2.01 + D1.06a/c + D2.06b/d
- Wall thickness 17.5:
Fig. D2.02 + D1.06a/c + D2.06b/d
- Wall thickness 20:
Fig. D2.03 + D1.06a/c + D2.06b/d
- Wall thickness 24 / 25:
Fig. D2.04 + D1.06a/c + D2.06b/d
- Wall thickness 30:
Fig. D2.05 + D1.06a/c + D2.06b/d

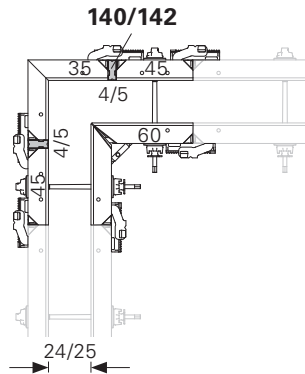

Fig. D2.04

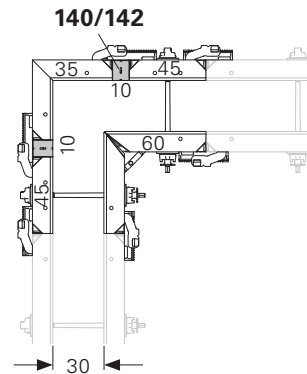

Fig. D2.05

Compensations

- Wall thickness 15 + 17.5 cm:
external compensation
- Wall thickness 20 cm:
without compensation
- Wall thickness 24 + 25 + 30 cm:
external compensation

Wall Thicknesses 30 – 40 cm
Height 2.70 m or 3.30 m

Outside Corner MXA 270/330 x 45



Perm. fresh concrete pressure: 80 kN/m²

Components

20	Alignment Coupler BFD
106/126	Panel MX 18, 270/330 x 240
140/142	Wall Thickness Compensator WDA MX or filler timber supplied by contractor ≤ 10 cm
151/159	Outside Corner MXA 270/330 x 45
152/160	Inside Corner MXI 18, 270/330 x 60

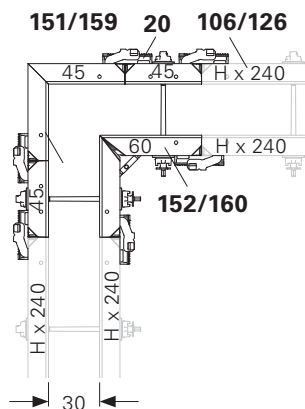

Fig. D2.06

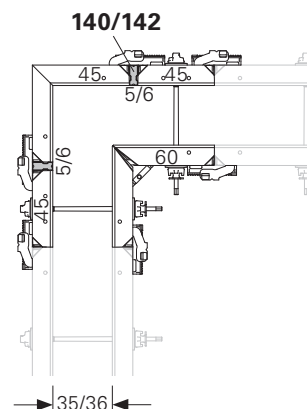

Fig. D2.07

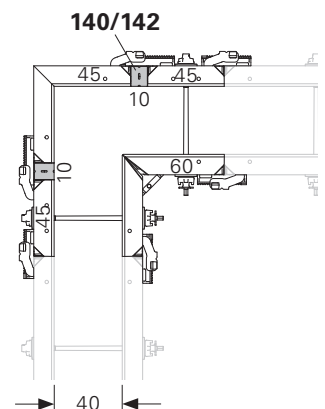

Fig. D2.08

Examples

- Wall thickness 30:
Fig. D2.06 + D1.06a/c + D2.06b/d
- Wall thickness 35 / 36:
Fig. D2.07 + D1.06a/c + D2.06b/d
- Wall thickness 40:
Fig. D2.08 + D1.06a/c + D2.06b/d

Compensations

- Wall thickness 30 cm:
without compensation
- Wall thickness 35 + 40 cm:
external compensation

D2 90° Corners with Inside Corner MXI 18, 270/330 x 60

Arrangement of the Alignment Couplers Outside Corner MXA height x 45 / ... x 35

Height 270 cm
(Fig. D2.06a + D2.06b)

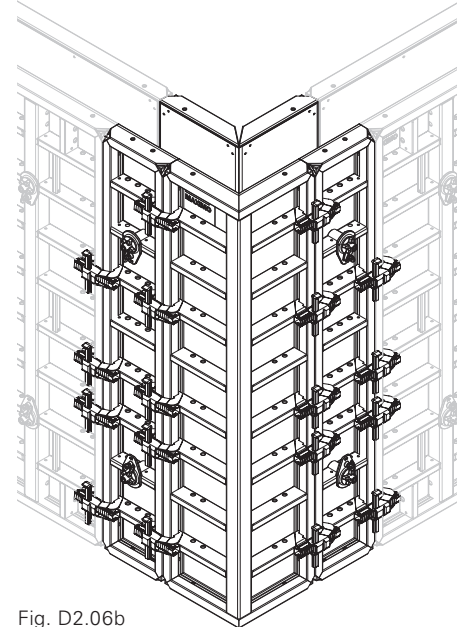
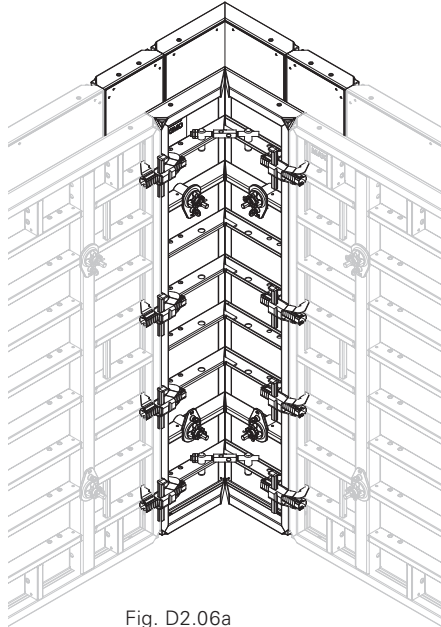

Height 330 cm
(Fig. D2.06c + D2.06d)

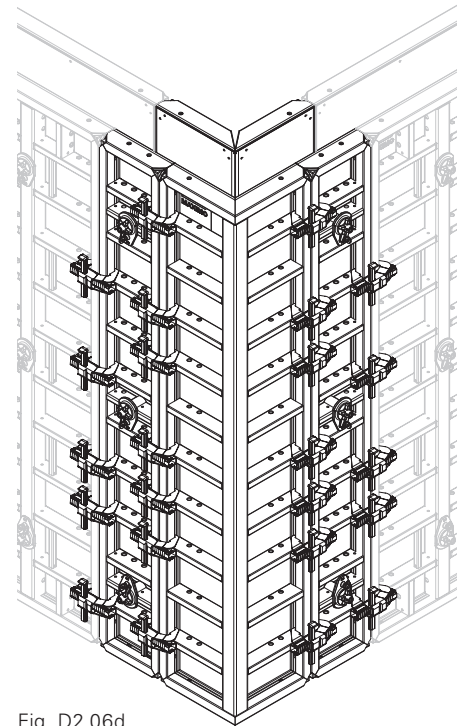
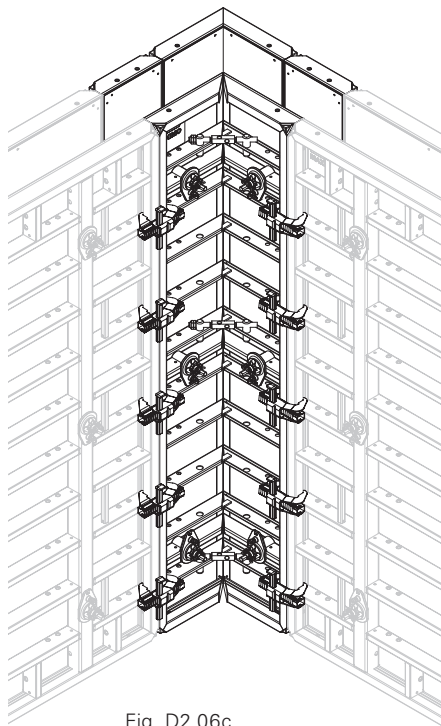

D2 90° Corners with Inside Corner MXI 18, 270/330 x 60

Wall Thicknesses > 40 – 60 cm
Height (H) 2.70 m / 3.30 m

Outside Corner MXA 270/330 x 45



Perm. fresh concrete pressure: 60 kN/m²

Components

20	Alignment Coupler BFD
21	Compensation Waler MAR 85-3
22	Compensation Waler MAR 170-3
100/120	Panel MXM 18, 270/330 x 60
101/121	Panel MX 18, 270/330 x 30
102/122	Panel MX 18, 270/330 x 45
106/126	Panel MX 18, 270/330 x 240
140/142	Wall Thickness Compensator WDA MX or filler timber supplied by contractor ≤ 10 cm
152/160	Inside Corner MXI 18, 270/330 x 60

Examples

- Wall thickness 45:
Fig. D2.09 + D2.09a/c + D2.09b/d
- Wall thickness 50:
Fig. D2.10 + D2.09a/c + D2.09b/d
- Wall thickness 55:
Fig. D2.11 + D2.09a/c + D2.09b/d
- Wall thickness 60:
Fig. D2.12 + D2.09a/c + D2.09b/d

Compensations

- Wall thickness:
without compensation
Wall thickness 50 + 55 cm:
external compensation
Wall thickness 60 cm:
without compensation

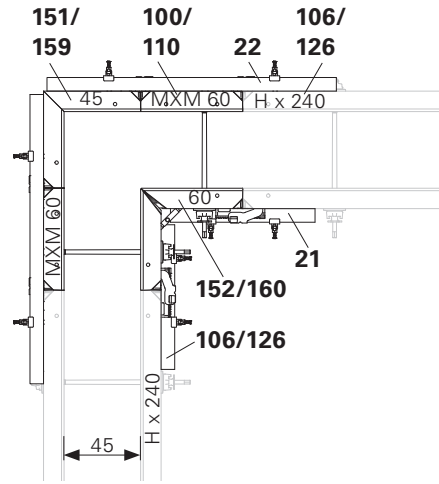

Fig. D2.09

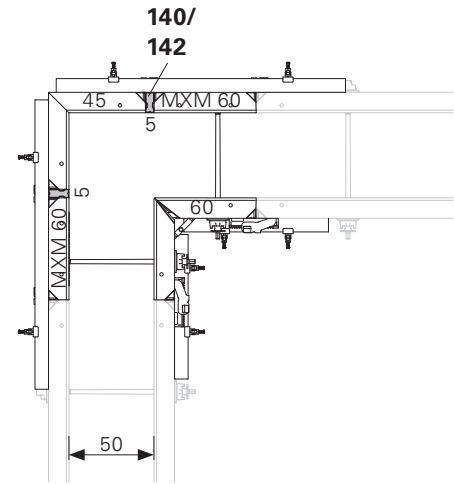

Fig. D2.10

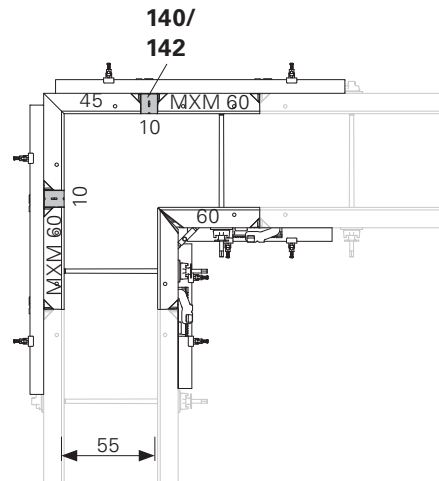

Fig. D2.11

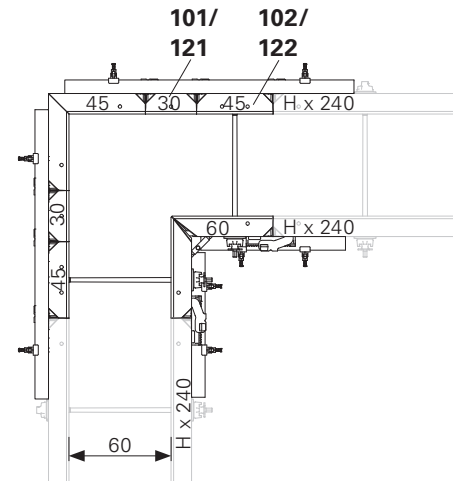

Fig. D2.12

D2 90° Corners with Inside Corner MXI 18, 270/330 x 60

Arrangement of the Alignment Couplers and Compensation Walers

Height 270 cm
(Fig. D2.09a + D2.09b)

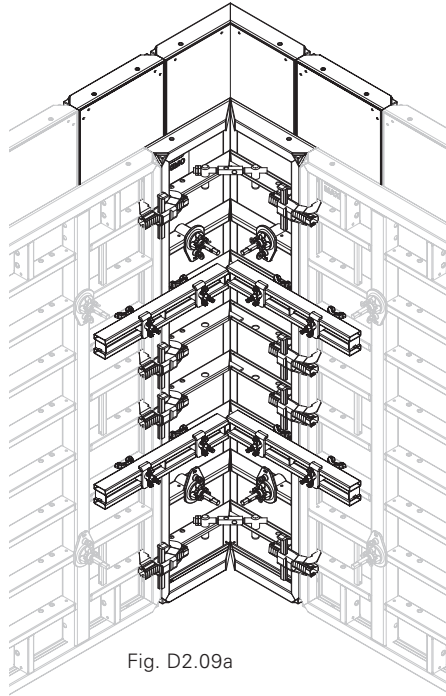

Fig. D2.09a

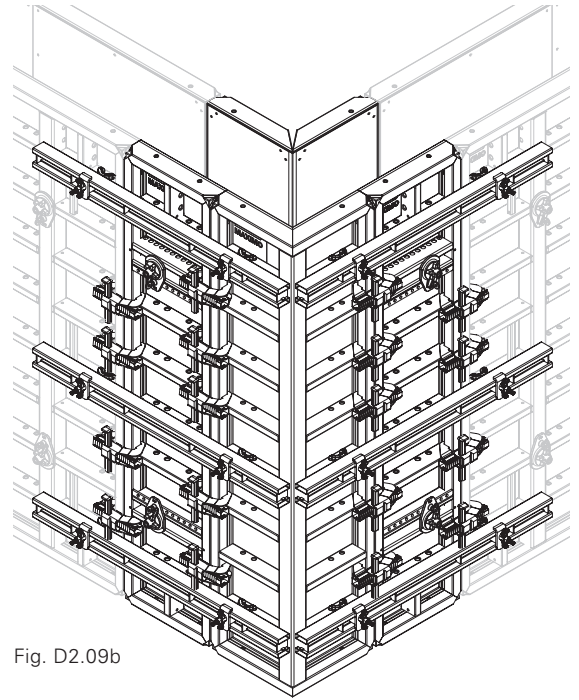

Fig. D2.09b

Height 330 cm
(Fig. D2.09c + D2.09d)

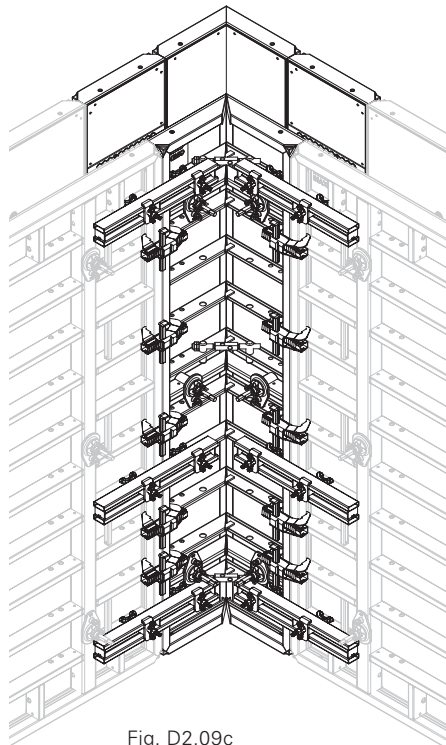

Fig. D2.09c

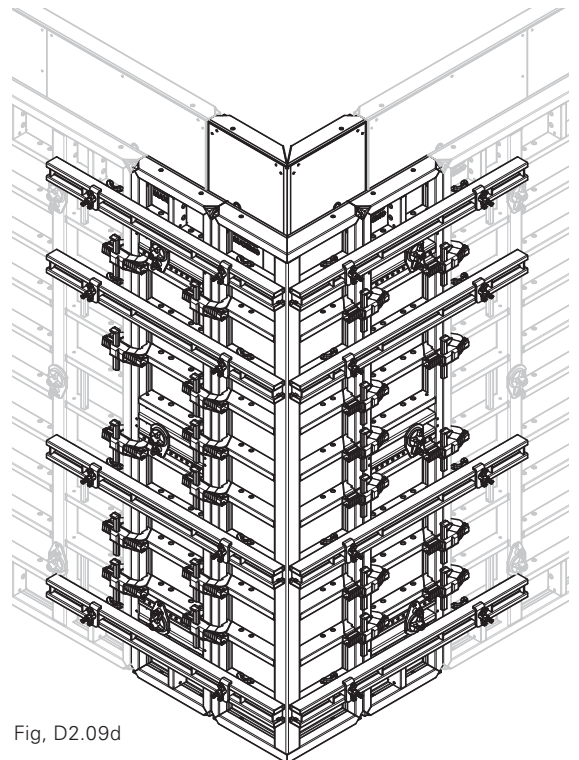

Fig. D2.09d

D3 90° T-junctions with Inside Corner MXI 18, 270/330 x 60

Wall Thicknesses 15 – 40 cm
Height (H) 2.70 m or 3.30 m



Perm. fresh concrete pressure: 80 kN/m²

Components

20	Alignment Coupler BFD
22	Compensation Waler MAR 170-3
102/122	Panel MX 18, 270/330 x 45
103/123	Panel MX 18, 270/330 x 60
106/126	Panel MX 18, 270/330 x 240
140/142	Wall Thickness Compensator WDA MX 270/330 or filler timber supplied by contractor ≤10 cm
152/160	Inside Corner MXI 18, 270/330 x 60

Assembly

1. Form T-junction with Inside Corner MXI 18, H x 60 (152/160).
2. Form the opposite straight wall with Panel MX 18, H x 45 (102/122) or MX 18, H x 60 (103/123).
3. Install one Panel MX 18, H x 45 (102/122) each on the right and on the left.
4. Install Wall Thickness Compensator (140/142) – according to the wall thickness, if necessary.
5. On the straight wall, install Compensation Waler MAR 170 (22) centrally to the outgoing wall.



Attach the double hook of the Compensation Waler to the middle holes. (Fig. D3.08)

Examples

- Wall thickness 15:
Fig. D3.01 + D3.05a/c + D3.05b/d
- Wall thickness 17.5:
Fig. D3.02 + D3.05a/c + D3.05b/d
- Wall thickness 20:
Fig. D3.03 + D3.05a/c + D3.05b/d
- Wall thickness 24/25:
Fig. D3.04 + D3.05a/c + D3.05b/d
- Wall thickness 30:
Fig. D3.05 + D3.05a/c + D3.05b/d
- Wall thickness 35/36:
Fig. D3.06 + D3.05a/c + D3.05b/d
- Wall thickness 40:
Fig. D3.07 + D3.05a/c + D3.05b/d

Compensations

- Wall thickness 15 + 30 cm:
without compensation
- Wall thickness 17.5 + 20 + 24 + 25 +
wall thickness 35 + 36 + 40 cm:
external compensation

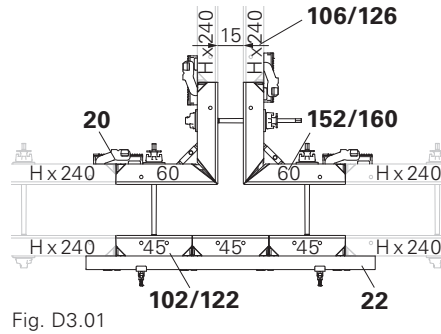

Fig. D3.01

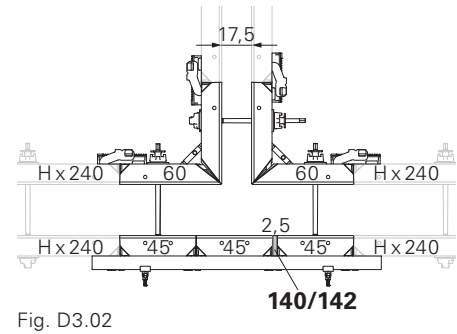

Fig. D3.02

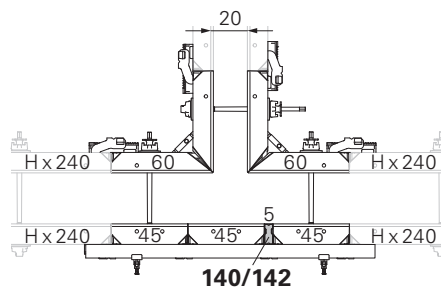

Fig. D3.03

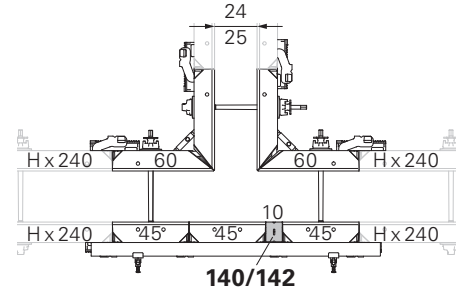

Fig. D3.04

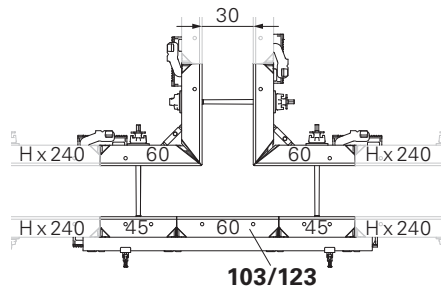

Fig. D3.05

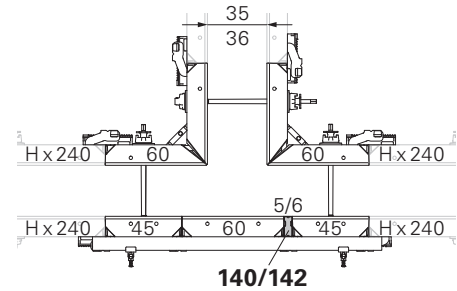

Fig. D3.06

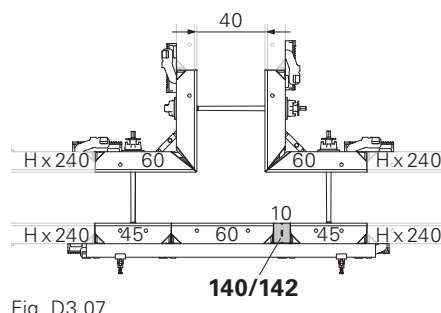

Fig. D3.07

„X“
from Fig. D3.05b

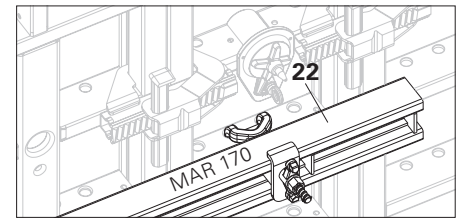

Fig. D3.08



With two Wall Thickness Compensators WDA MX (not shown): install one WDA MX each on the right and left of the middle panel.

D3 90° T-junctions with Inside Corner MXI 18, 270/330 x 60

Arrangement of the Alignment Couplers
Outside Corner MXA height x 45 /... x 35

Height 270 cm
(Fig. D3.05a + D3.05b)

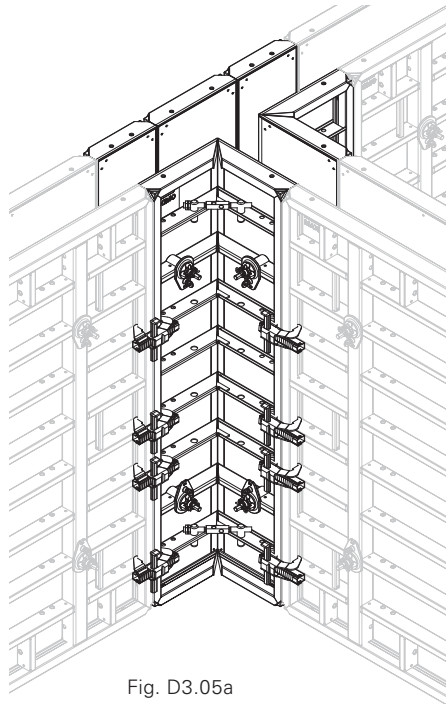

Fig. D3.05a

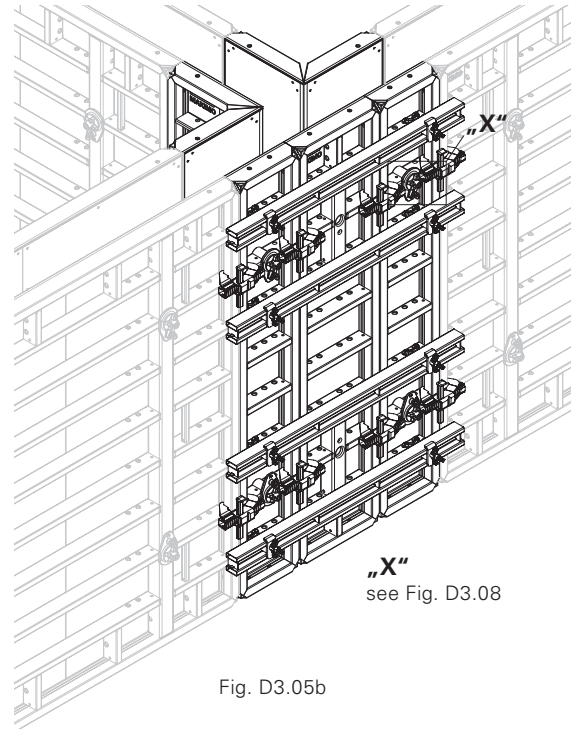

Fig. D3.05b

Height 330 cm
(Fig. D3.05c + D3.05d)

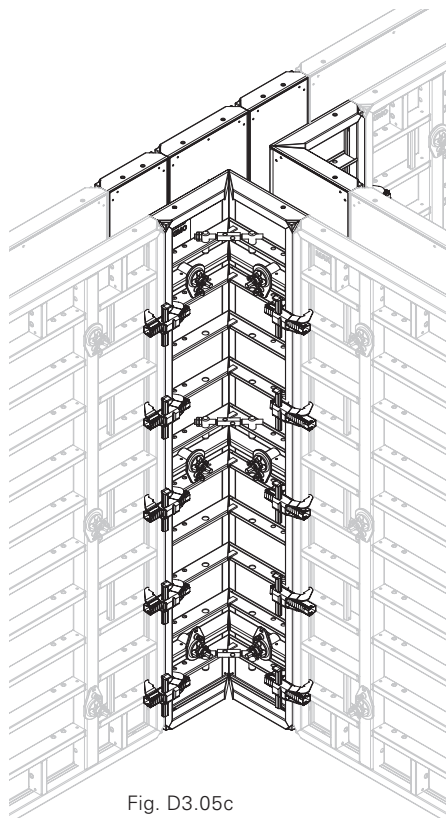

Fig. D3.05c

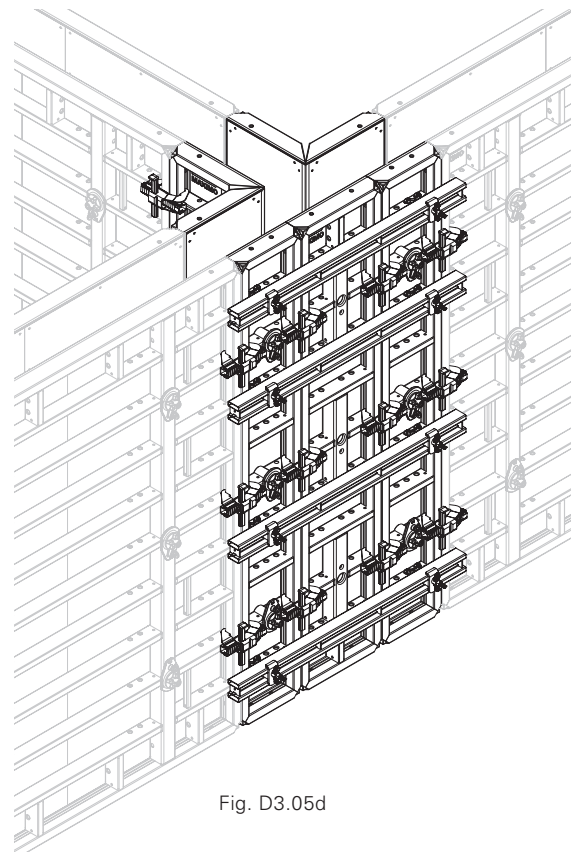

Fig. D3.05d

D3 90° T-junctions with Inside Corner MXI 18, 270/330 x 60

Wall Thicknesses > 40 – 60 cm
Height (H) 2.70 m or 3.30 m



Perm. fresh concrete pressure: 60 kN/m²

Components

20	Alignment Coupler BFD
23	Wingnut Pivot Plate DW 15
25	Tie Rod DW 15
29	Steel Waler SRU 197 U120
102/122	Panel MX 18, 270/330 x 45
103/123	Panel MX 18, 270/330 x 60
106/126	Panel MX 18, 270/330 x 240
140/142	Wall Thickness Compensator WDA MX 270/330 or filler timber supplied by contractor ≤ 10 cm
152/160	Inside Corner MXI 18, 270/330 x 60

Assembly

1. Form T-junction with Inside Corner MXI 18, H x 60 (152/160).
2. Form the opposite straight wall with Panel MX 18, H x 45 (102/122) or MX 18, H x 60 (103/123).
3. Install one Panel MX 18, H x 60 (103/123) each on the right and left.
4. Install Wall Thickness Compensator (140/142) – according to the wall thickness, if necessary.
5. On the straight wall, install the Steel Waler (25) with Hook Tie (24) and Wingnut Pivot Plate (23) centrally to the T-junction.

Examples

- Wall thickness 45:
Fig. D3.09 + D3.09a/c + D3.09b/d
- Wall thickness 50:
Fig. D3.10 + D3.09a/c + D3.09b/d
- Wall thickness 55:
Fig. D3.11 + D3.09a/c + D3.09b/d
- Wall thickness 60:
Fig. D3.12 + D3.09a/c + D3.09b/d

Compensations

- Wall thickness 45 cm + 60 cm:
without compensation
- Wall thickness 50 cm + 55 cm:
external compensation



With two Wall Thickness Compensators WDA MX (not shown):
install one WDA MX each on the right and left of the middle panel.

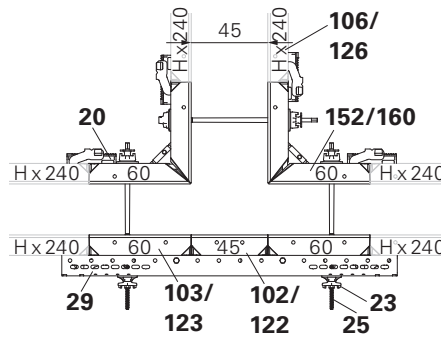

Fig. D3.09

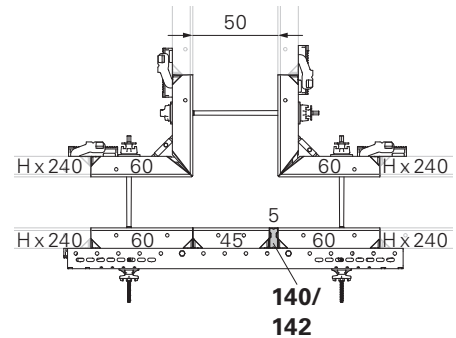

Fig. D3.10

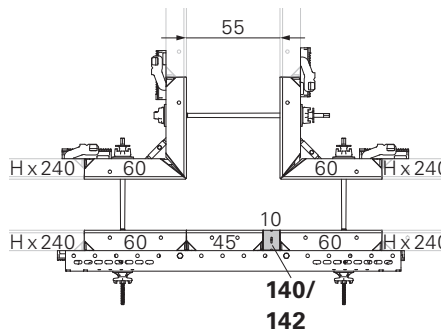

Fig. D3.11

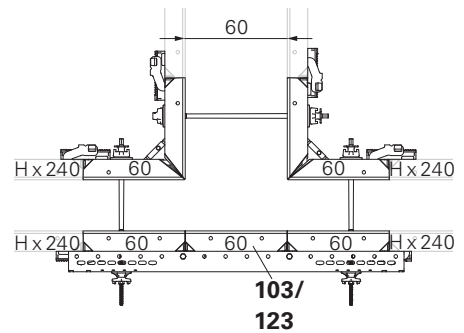

Fig. D3.12

D3 90° T-junctions with Inside Corner MXI 18, 270/330 x 60

Arrangement of the Alignment Couplers
Outside Corner MXA height x 45 /... x 35

Height 270 cm
(Fig. D3.09a + D3.09b)

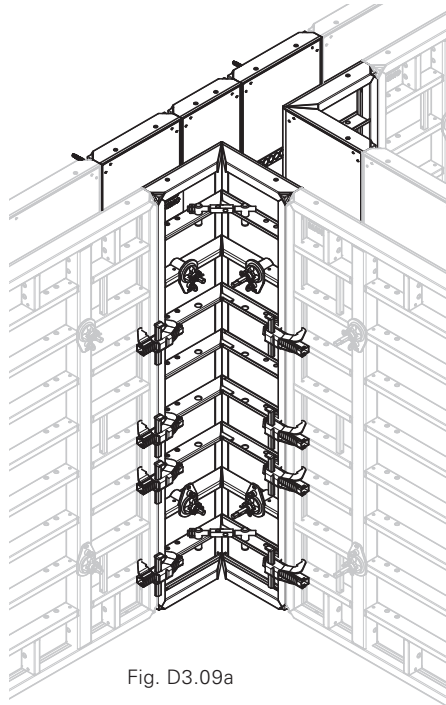

Fig. D3.09a

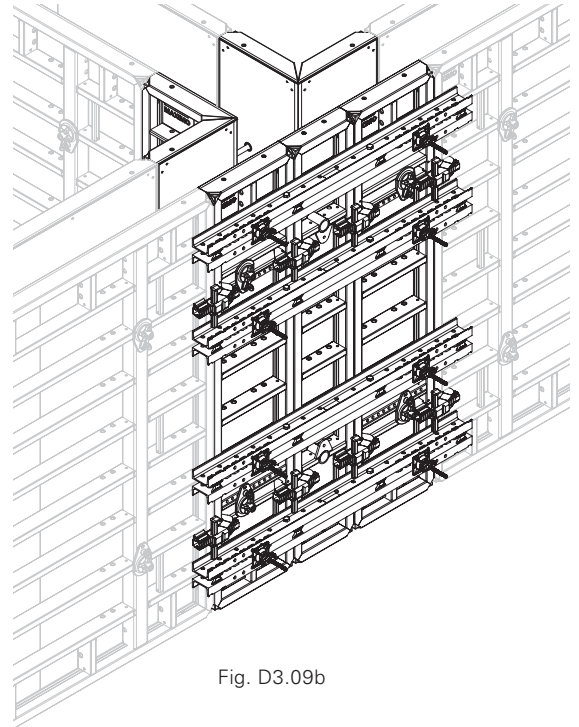

Fig. D3.09b

Height 330 cm
(Fig. D3.09c + D3.09d)

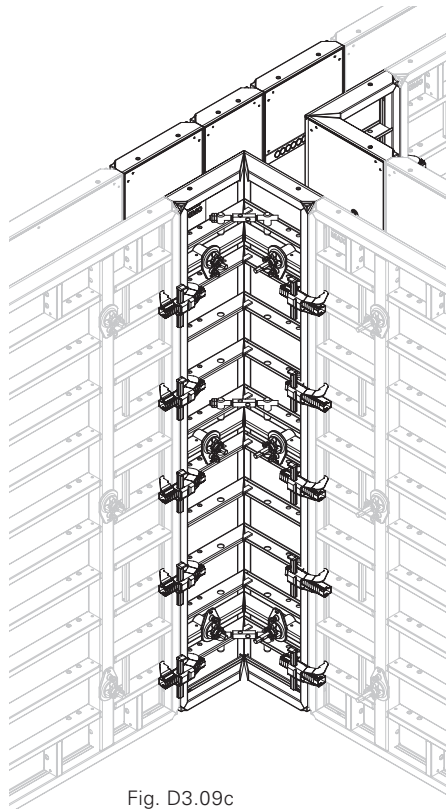

Fig. D3.09c

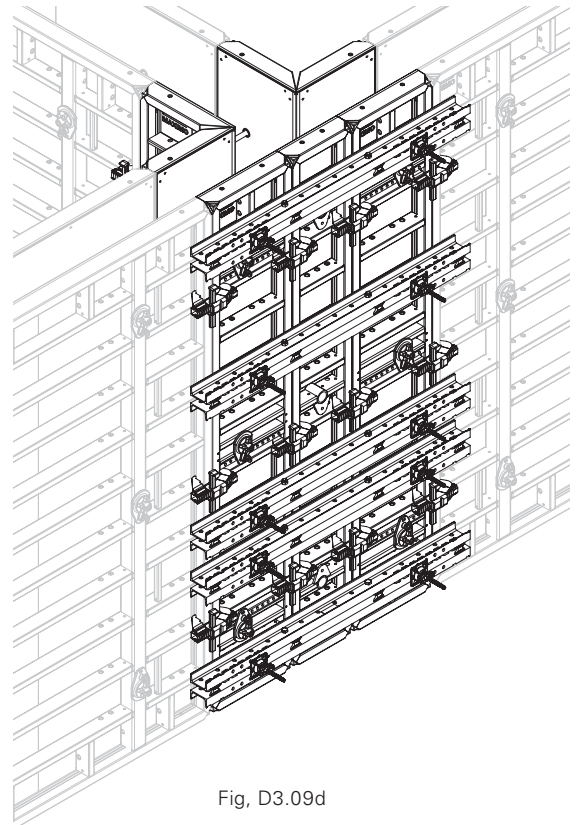

Fig. D3.09d

Inside Corner MXI 18, 270/330 x 50/20

Outside Corner MXA 18, 270/330 x 45



Perm. fresh concrete pressure: 60 kN/m²

Components

19	Waler Stop
20	Alignment Coupler BFD
23	Wingnut Pivot Plate DW 15
24	Hook Tie DW 15/400
25	Tie Rod DW 15
29	Steel Waler SRU 247 U120
36	Tie Rod DW 20
37	Spacer Tube DR 28
38	DK Sealing Cone DW 30/55
39	Wingnut Pivot Plate DW 20
44	Wingnut DW 15
48	Wedge KZ
49	Tie Yoke SW
101/121	Panel MX 18, 270/330 x 30
102/122	Panel MX 18, 270/330 x 45
103/123	Panel MX 18, 270/330 x 60
106/126	Panel MX 18, 270/330 x 240
140/142	Wall Thickness Compensator WDA MX 270/330 or filler timber supplied by contractor ≤ 10 cm
151/159	Outside Corner MXA 18, 270/330 x 45
153/161	Inside Corner MXI 18, 270/330 x 60

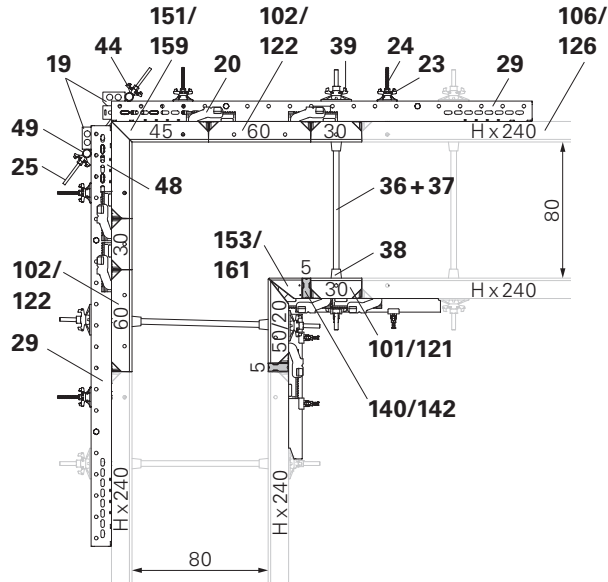

Fig. D4.01

Examples

- Wall thickness 80 / Height 270:
Fig. D4.01 + D4.01a + D4.01b.
- Wall thickness 80 / Height 330:
Fig. D4.01 + D4.01c + D4.01d.

D4 90° Corners for 80 cm Wall Thickness

Arrangement of the Alignment Couplers and Steel Walers

Height 270 cm

(Fig. D4.01a + D4.01b)

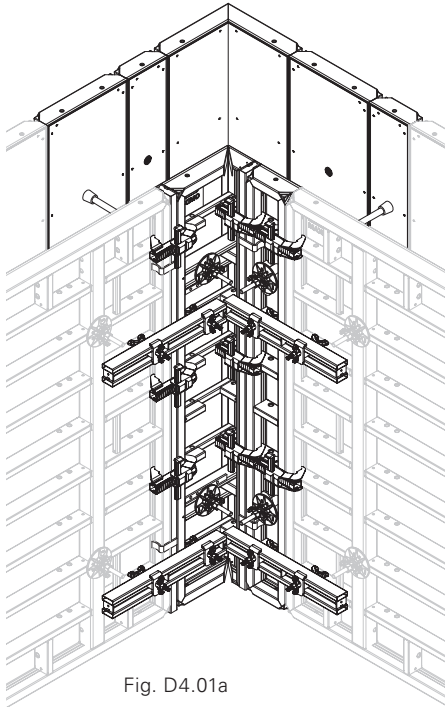

Fig. D4.01a

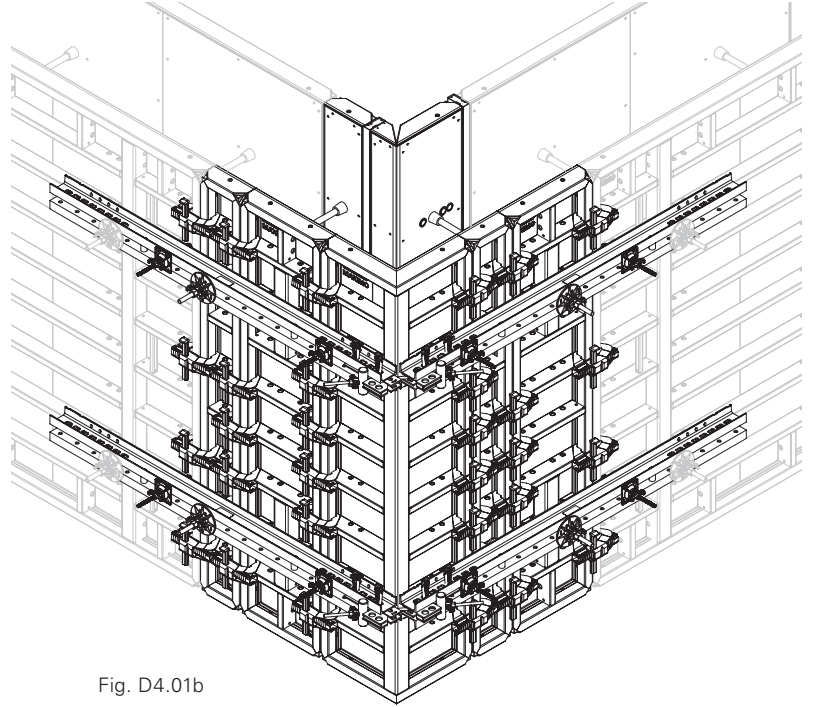

Fig. D4.01b

Height 330 cm

(Fig. D4.01c + D4.01d)

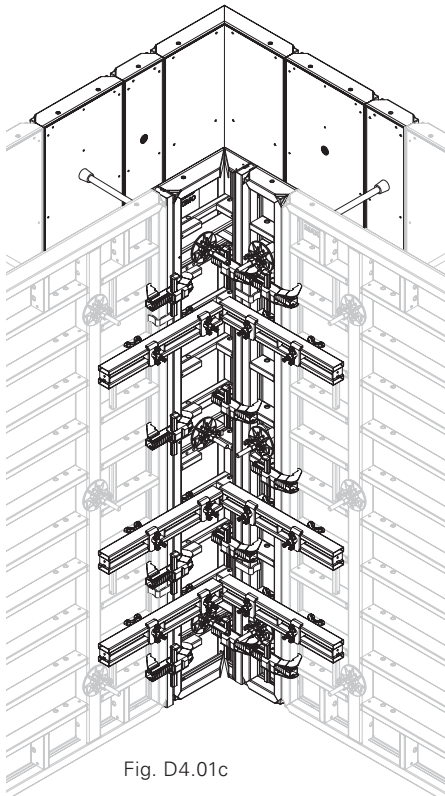

Fig. D4.01c

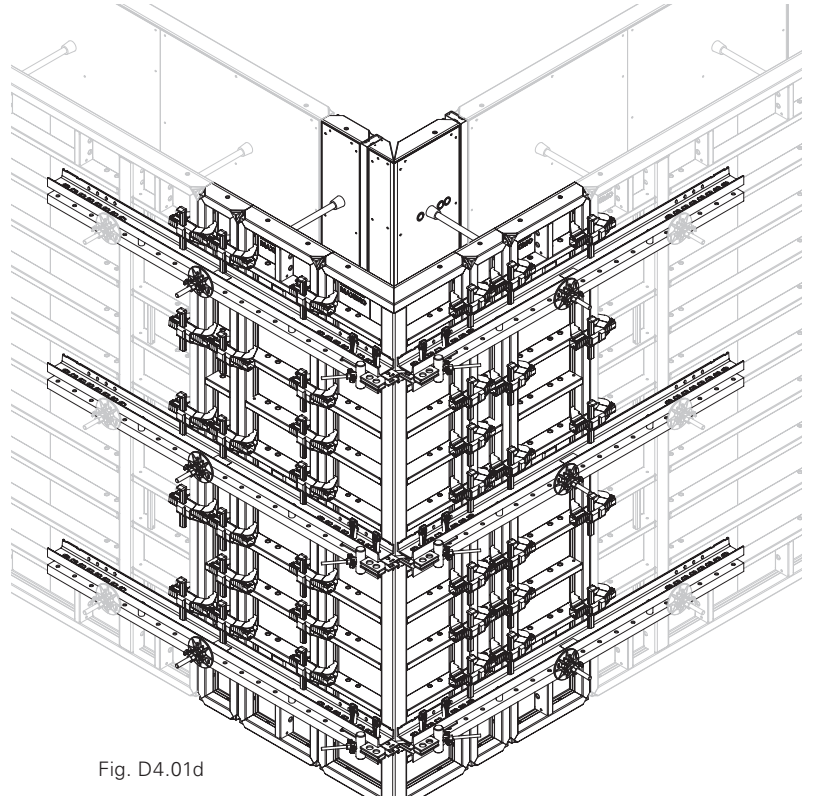

Fig. D4.01d

Inside Corner MXI 18, 270/330 x 60

Outside Corner MXA 18, 270/330 x 45



Perm. fresh concrete pressure: 60 kN/m²

Components

19	Waler Stop
20	Alignment Coupler BFD
23	Wingnut Pivot Plate DW 15
24	Hook Tie DW 15/400
25	Tie Rod DW 15
29	Steel Waler SRU 247 U120
36	Tie Rod DW 20
37	Spacer Tube DR 28
38	DK Sealing Cone DW 30/55
39	Wingnut Pivot Plate DW 20
44	Wingnut DW 15
48	Wedge KZ
49	Tie Yoke SW
102/122	Panel MX 18, 270/330 x 45
103/123	Panel MX 18, 270/330 x 60
106/126	Panel MX 18, 270/330 x 240
140/142	Wall Thickness Compensator WDA MX 270/330 or filler timber supplied by contractor ≤ 10 cm
151/159	Outside Corner MXA 18, 270/330 x 45
153/161	Inside Corner MXI 18, 270/330 x 60



Abb. D4.02

Examples

- Wall thickness 80 / Height 270:
Fig. D4.02 + D4.02a + D4.02b.
- Wall thickness 80 / Height 330:
Fig. D4.02 + D4.02c + D4.02d.

D4 90° Corners for 80 cm Wall Thickness

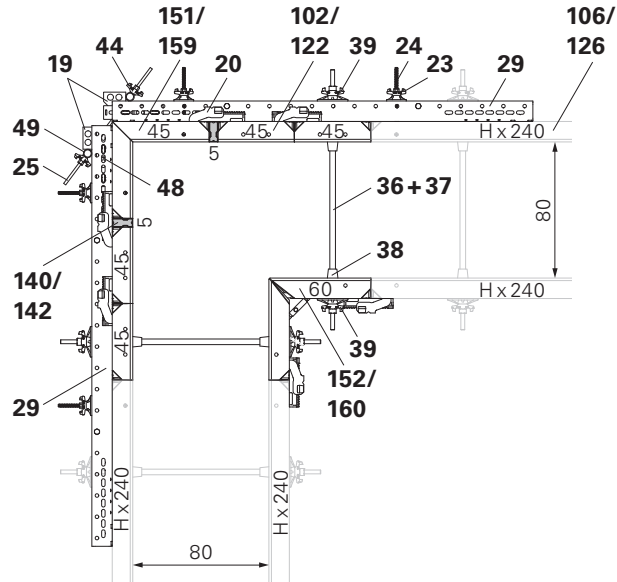
Arrangement of the Alignment Couplers and Steel Walers

Height 270 cm

(Fig. D4.02a + D4.02b)

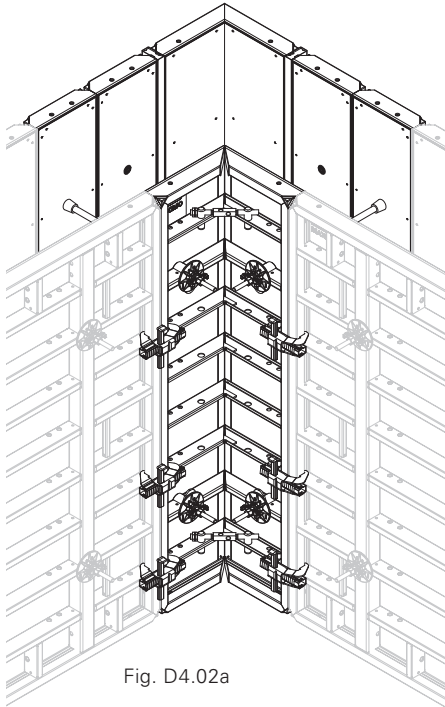

Fig. D4.02a

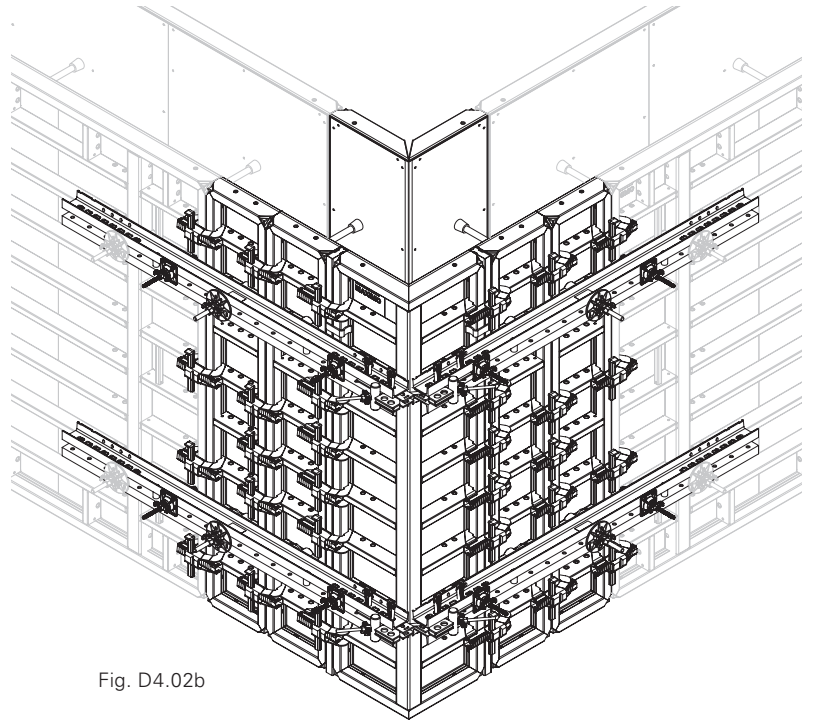

Fig. D4.02b

Height 330 cm

(Fig. D4.02c + D4.02d)

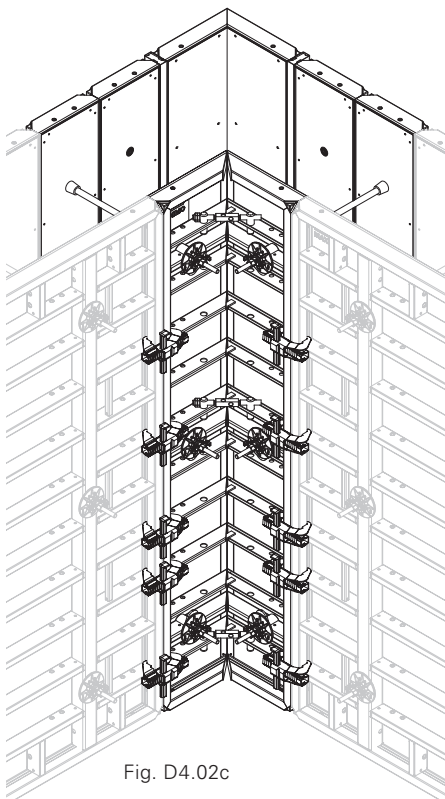

Fig. D4.02c

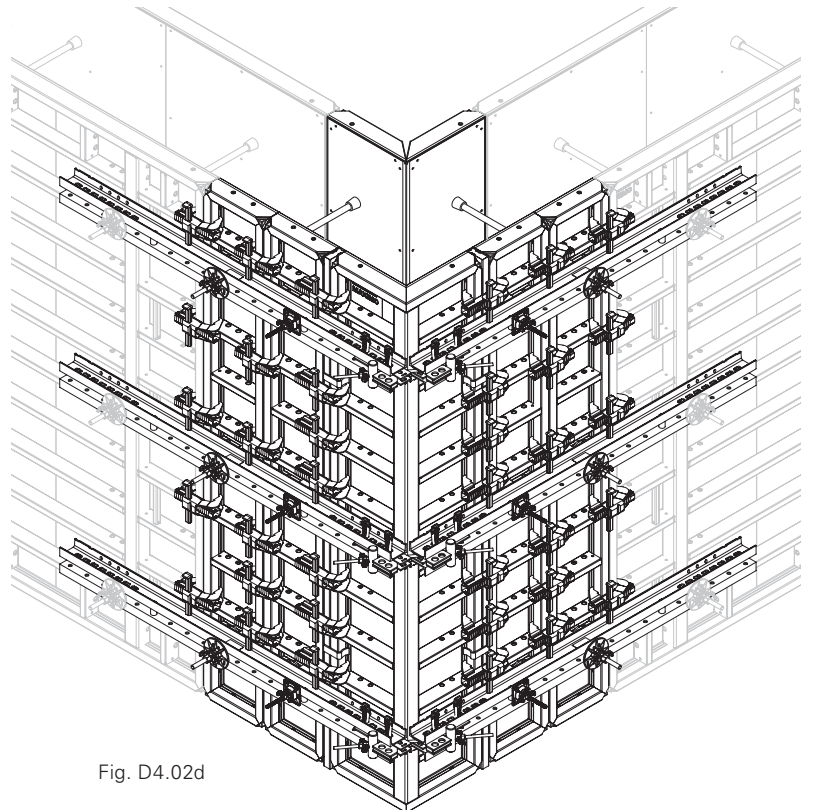

Fig. D4.02d

Shaft Corner MXSE 18



Not permissible for other formwork systems!

Panel heights

Four panel heights allow fast striking and moving of the shaft formwork.

- 1.20 m (Fig. D5.01a)
- 2.70 m (Fig. D5.01b)
- 3.30 m (Fig. D5.01c)

Components

80	Shaft Corner MXSE 18, height
80.1	Tie Point
80.2	Load-bearing point 2 t
80.3	Bolts and cotter pins
80.4	Openings for shuttering and striking
80.5	Positioning Waler MXSE
81	Shaft Corner MXSE 18, 120
82	Shaft Corner MXSE 18, 270
84	Shaft Corner MXSE 18, 330



Horizontally pre-assemble the shaft formwork.

(Fig. D5.02a + D5.03a)

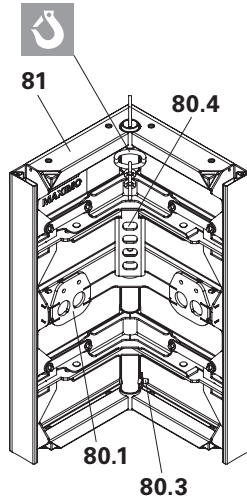

Fig. D5.01a

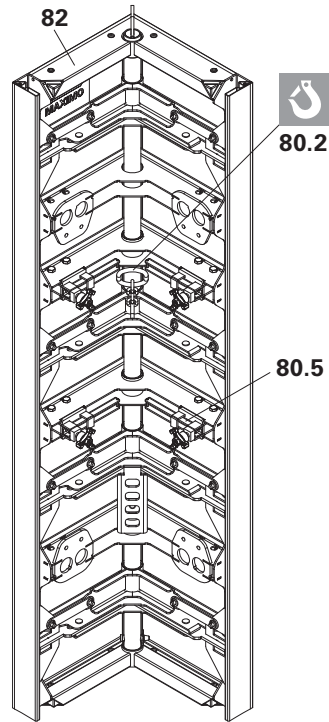

Fig. D5.01b

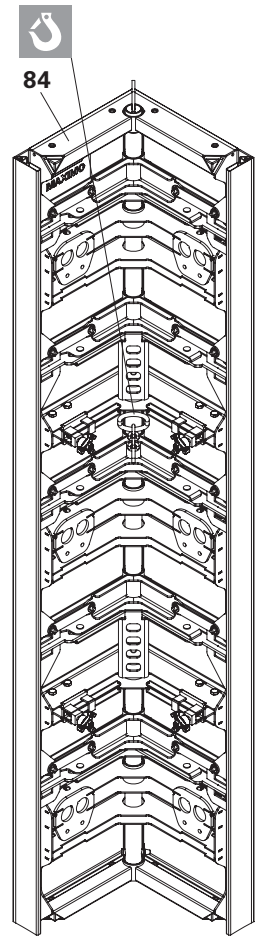

Fig. D5.01c

Crane lifting gear

Lifting Hook MAXIMO 1.5 t

For use with:

two Shaft Corners MXSE 18,
height 270/330 (82/84) and
two Inside Corners MXI 18,
height 270/330 x 50/20 (153/161).



- Perm. load-bearing capacity of the lifting hook: 1.5 t.
- Take into consideration Instructions for Use for the Lifting Hook MAXIMO 1.5 t!

Components

153/ Inside Corner MXI 18,	2x
161 270/330 x 50/20	
82/84 Shaft Corner MXSE 18,	2x
270/330	
16 Lifting Hook MAXIMO 1.5 t	2x

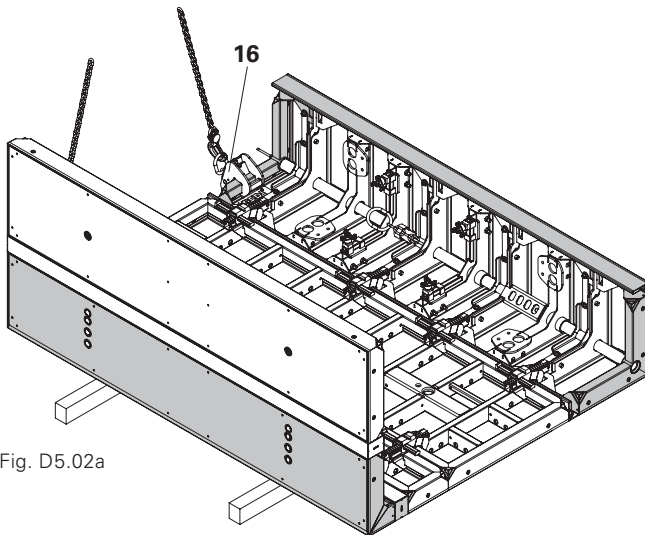

Fig. D5.02a

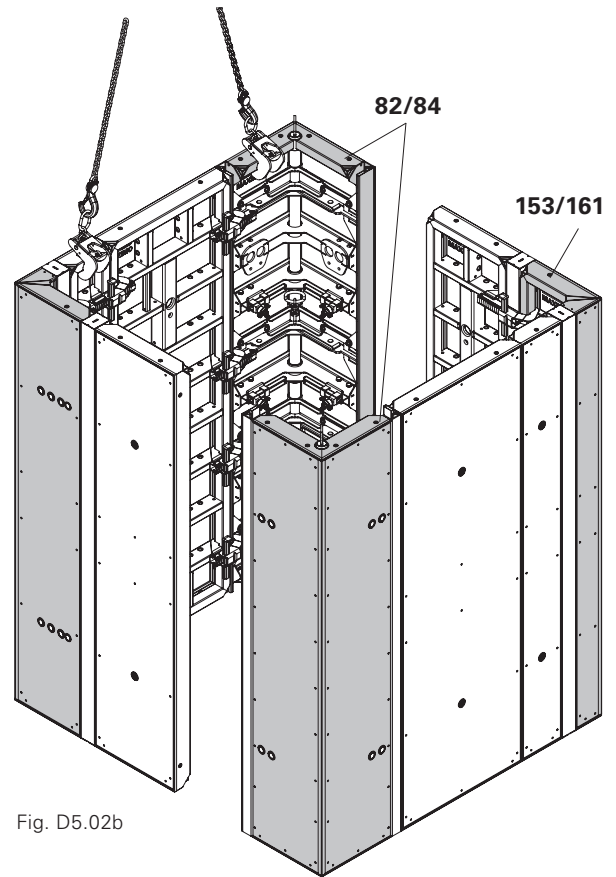

Fig. D5.02b

Lifting Gear Combi MX

For use with:

four Shaft Corners MXSE 18,
height 270/330 (82/84).



- Perm. load capacity of the load-bearing points: 2 t.
- Take into consideration Instructions for Use for the Lifting Gear Combi MX!

Components

82/84 Shaft Corner MXSE 18,	4x
270/330	
15 Lifting Gear Combi MX	1x

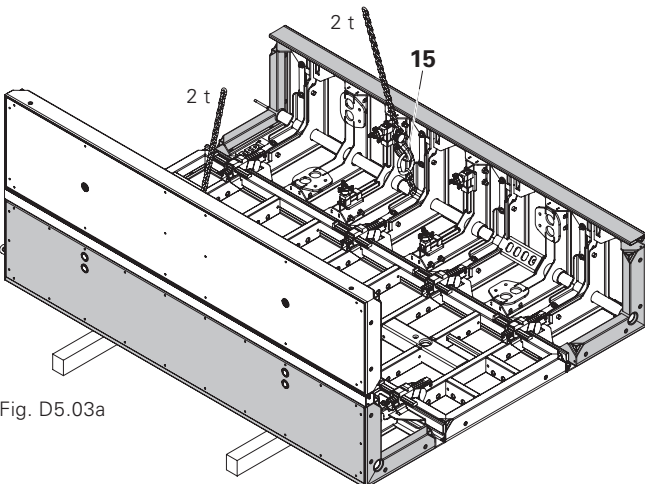

Fig. D5.03a

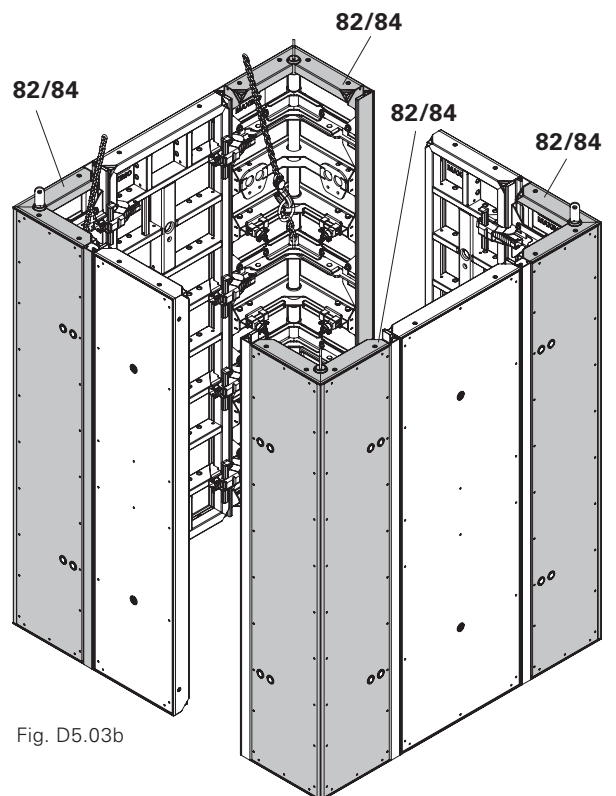

Fig. D5.03b

Shaft Corner MXSE 18, 270

Two Shaft Corners MXSE 18, 270
and
two Inside Corners MXI 18, 270 x 50/20

Height 270 cm

Corners of the inner shaft wall Components

20	Alignment Coupler BFD
82	Shaft Corner MXSE 18, 270
153	Inside Corner MXI 18, 270 x 50/20
101/102/	Panel MX 18,
103/104	270 x 30/45/60/90

Arrangement of the Alignment Couplers BFD

Shown:

- Shaft dimensions: 2.30 m x 2.60 m.
 - Wall thickness 25 cm.
- (Fig. D5.04)

Shaft Corner MXSE 18, 270 (82).
(Fig. D5.04a)

Inside Corner MXI 18, 270 x 50/20 (153).
(Fig. D5.04b)

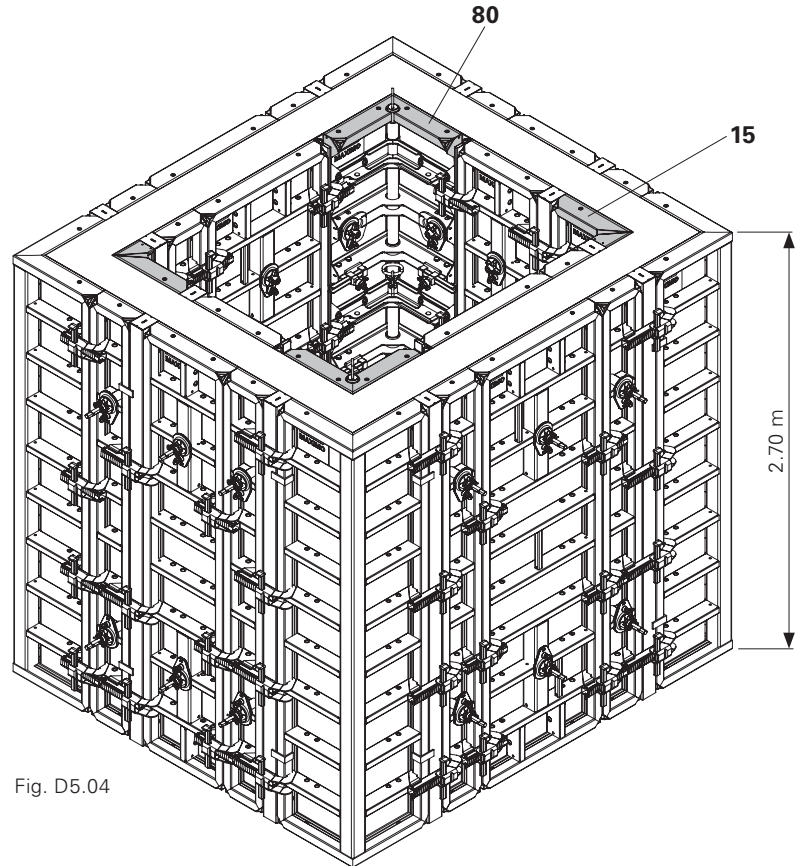

Fig. D5.04

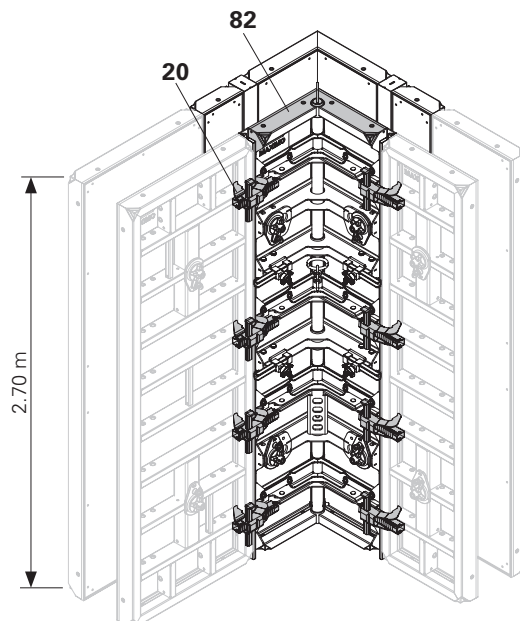

Fig. D5.04a

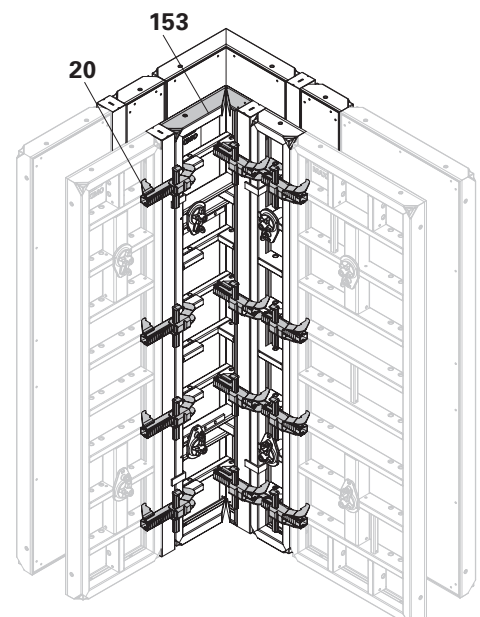

Fig. D5.04b

Four Shaft Corners MXSE 18, 270

Height 270 cm

Corners of the inner shaft wall Components

20	Alignment Coupler BFD
82	Shaft Corner MXSE 18, 270
104/	Panel MX 18,
105/106	270 x 90/120/240

Arrangement of the Alignment Couplers BFD

Shown:

- Shaft dimensions: 2.30 m x 2.60 m.
 - Wall thickness 25 cm.
- (Fig. D5.05)

Shaft Corner MXSE 18, 270 (82).
(Fig. D5.05a)

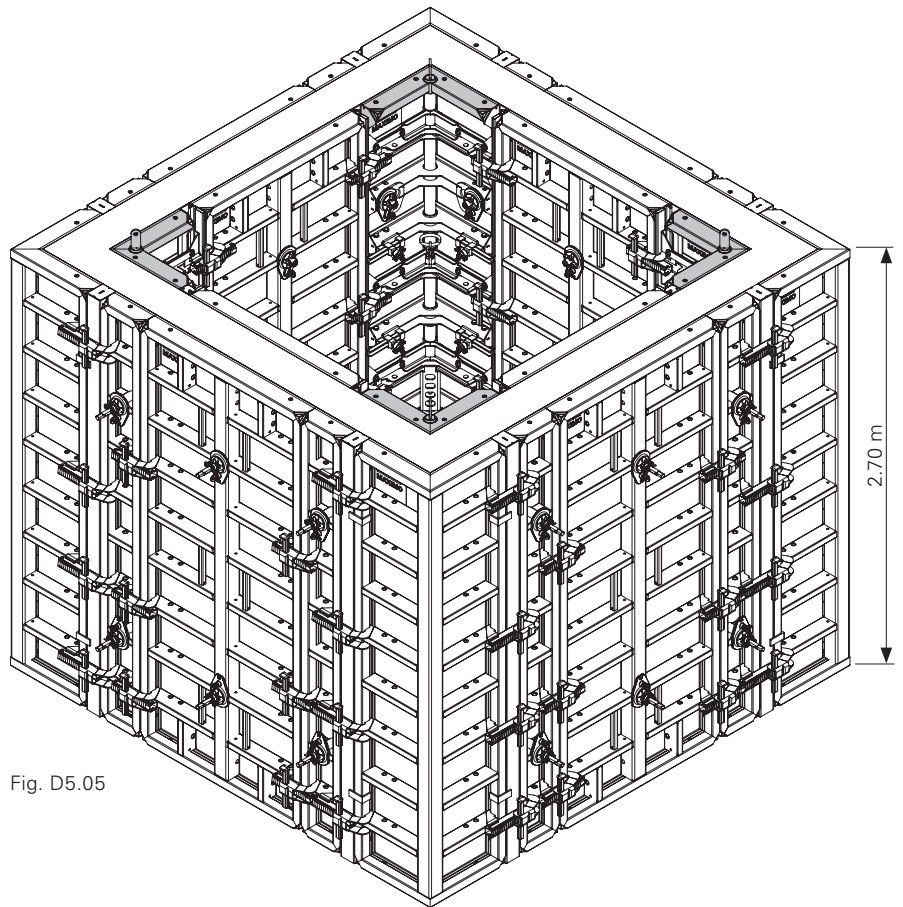

Fig. D5.05

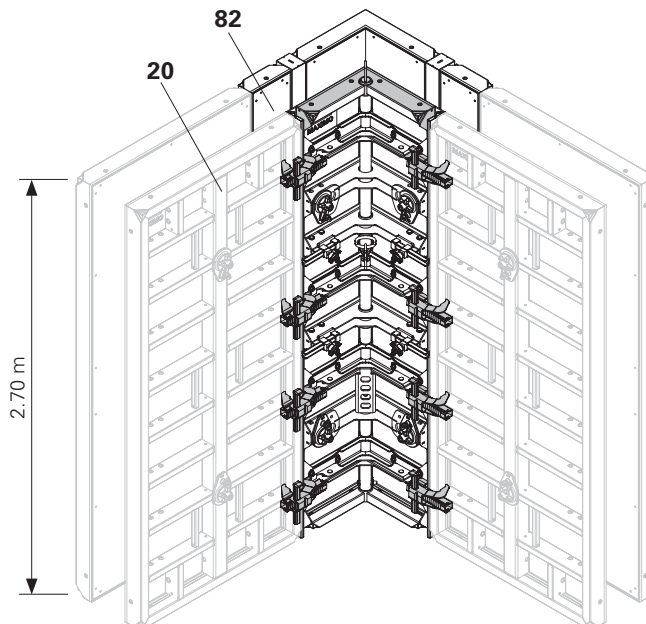

Fig. D5.05a

Shaft Corner MXSE 18, 330

Two Shaft Corners MXSE 18, 330
and
two Inside Corners MXI 18, 330 x 50/20

Height 330 cm

Corners of the inner shaft wall Components

20	Alignment Coupler BFD
84	Shaft Corner MXSE 18, 330
161	Inside Corner MXI 18, 330 x 50/20
121/122/	Panel MX 18,
123/124	330 x 30/45/60/90

Arrangement of the Alignment Couplers BFD

Shown:

- Shaft dimensions: 2.30 m x 2.60 m.
 - Wall thickness 25 cm.
- (Fig. D5.06)

Shaft Corner MXSE 18, 330 (84).
(Fig. D5.06a)

Inside Corner MXI 18, 330 x 50/20 (161).
(Fig. D5.06b)

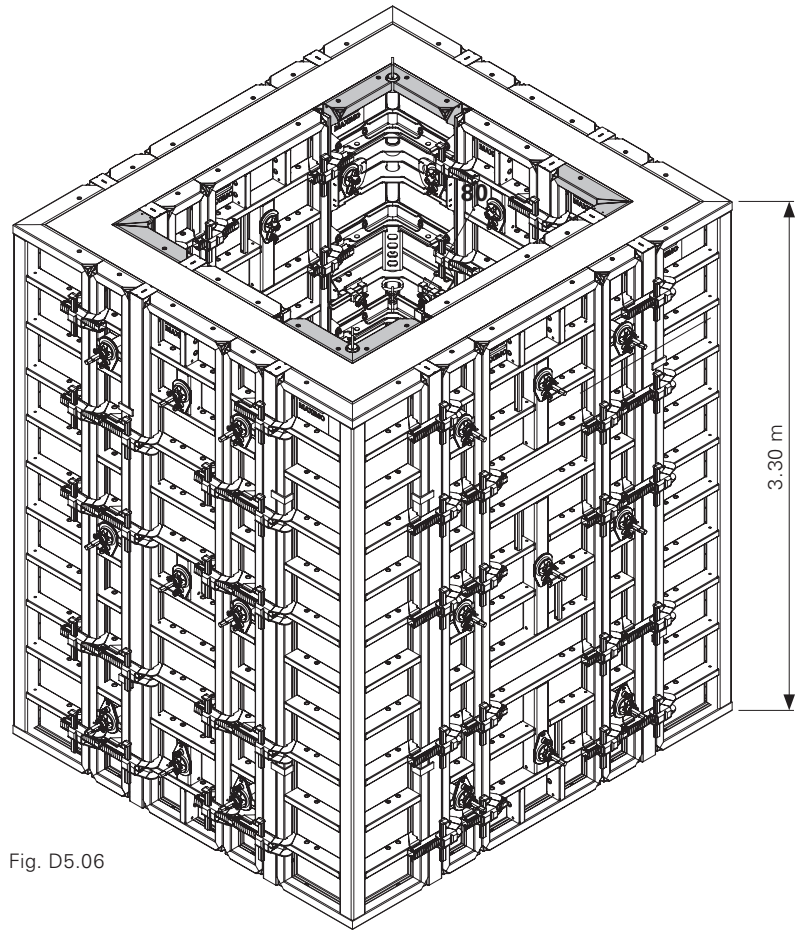

Fig. D5.06

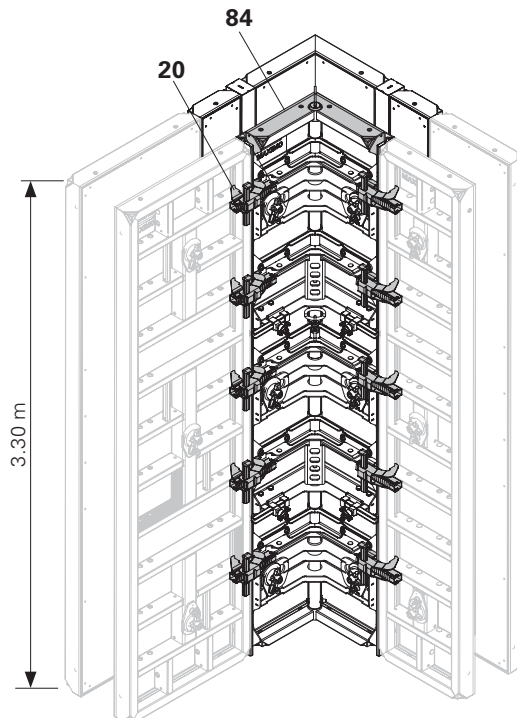

Fig. D5.06a

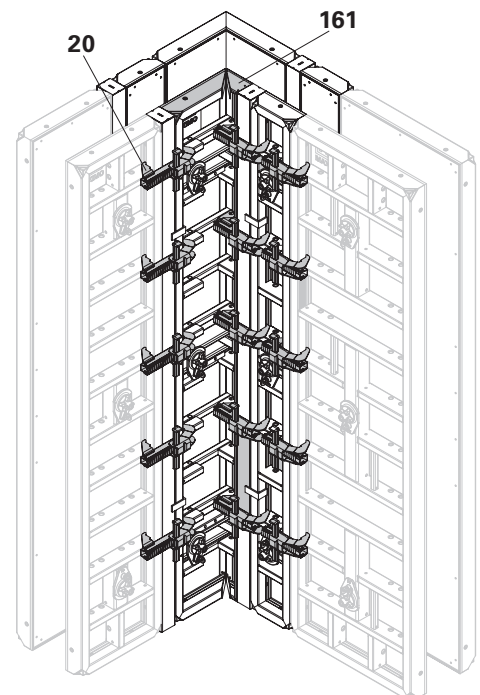

Fig. D5.06b

Four Shaft Corners MXSE 18, 330

Height 330 cm

Corners of the inner shaft wall Components

20	Alignment Coupler BFD
84	Shaft Corner MXSE 18, 330
124/126	Panel MX 18, 330 x 90/120/240

Arrangement of the Alignment Couplers BFD

Shown:

- Shaft dimensions: 2.30 m x 2.60 m.
 - Wall thickness 25 cm.
- (Fig. D5.07)

Shaft Corner MXSE 18, 330 (84).
(Fig. D5.07a)

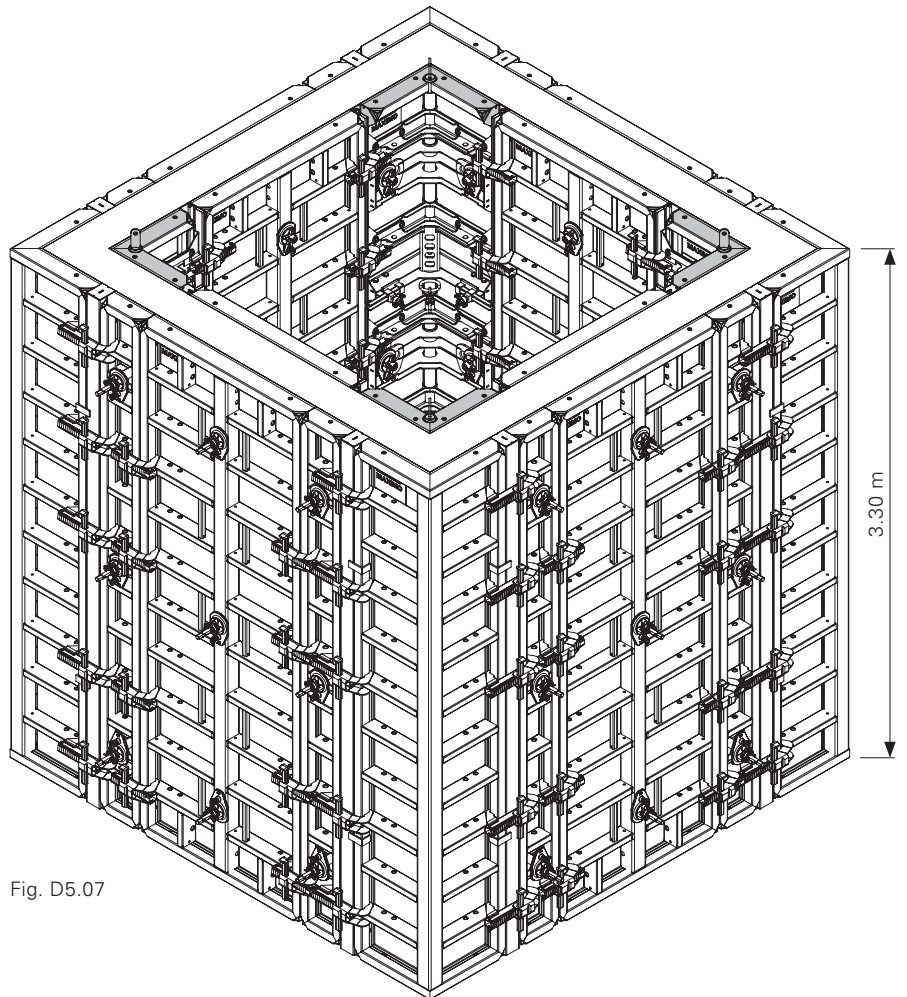

Fig. D5.07

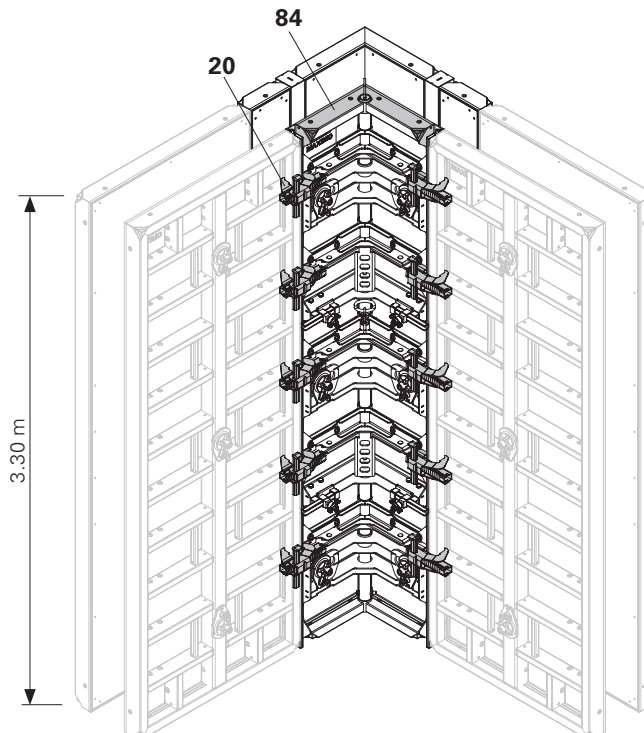

Fig. D5.07a

Shuttering



Before shuttering, check Tube and remove Transportation Securing Pins 20 x 102. Mount Swivel Nut MX 18 on the internal formwork.

Shuttering

1. Insert formwork lever into the opening (80.4) and press upwards.
→ The tube slides downwards.
2. Secure tube by means of pins 20 x 102 and cotter pins 5/1 (80.3). (Fig. D5.08 + D5.08b)
3. Push the slider of the Positioning Waler (80.5) over the profile until there is a flush fit and tighten the wingnuts. (Fig. D5.08 + D5.08a)

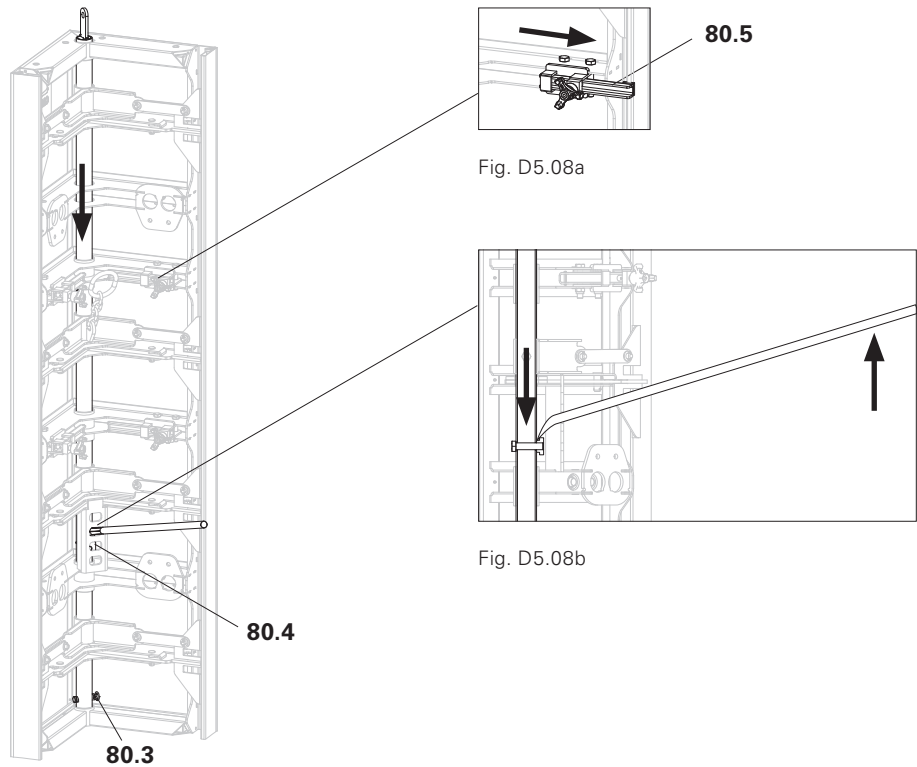

Fig. D5.08

Striking



Perm. load capacity of 2 t per load-bearing point!
Do not exceed the crane capacity!

Preparation

1. Remove tie points.
2. Loosen wingnuts on the Positioning Waler and push the slider back. (Fig. D5.09 + D5.09a)
3. Attach crane slings:
 - with four shaft corners, use all 4 load-bearing points,
 - with two shaft corners, use 2 load-bearing points.
4. Tension crane slings. (Fig. D5.09c)
5. Press crowbar downwards.
→ The tube slides upwards and the striking position has been adjusted.
6. Pull the complete internal formwork upwards, and move.
7. Insert pins 20 x 102 into the tube and secure with cotter pins 5/1 (80.3). (Fig. D5.09 + D5.09b)
→ Transport safety.

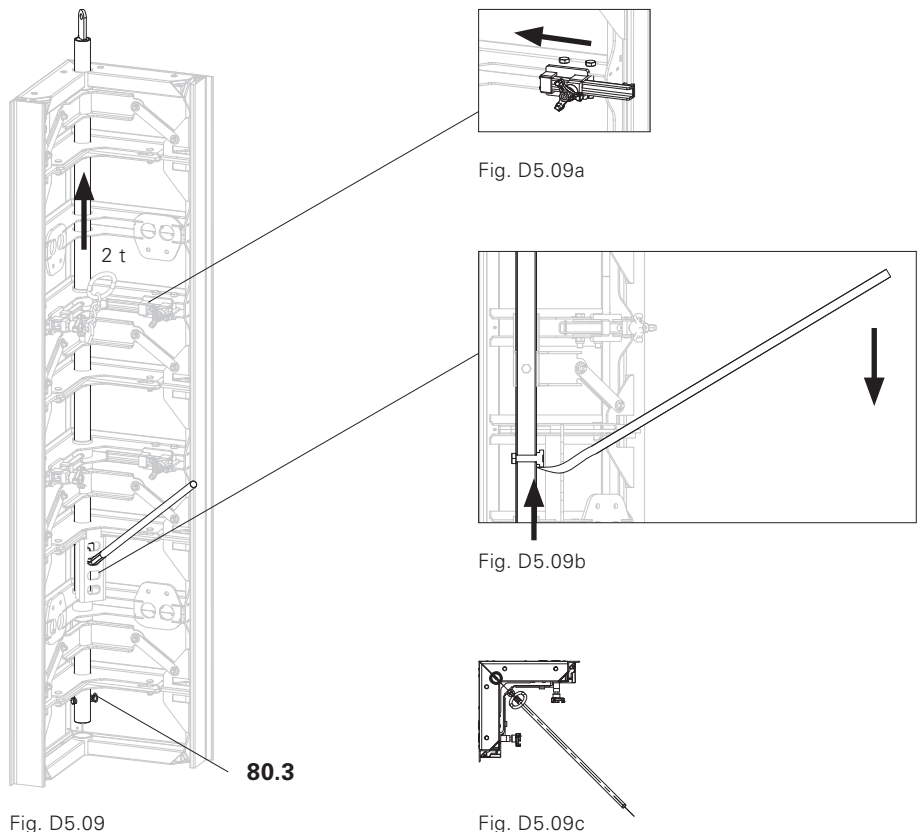

Fig. D5.09

Fig. D5.09c

Shaft with two Shaft Corners MXSE 18

The striking dimensions are reduced by 17.5 mm on each side of the shaft. (Fig. D5.10)



With boxouts, e.g. for doors or windows, be careful of nails of the mounting parts in the formlining!

shuttered

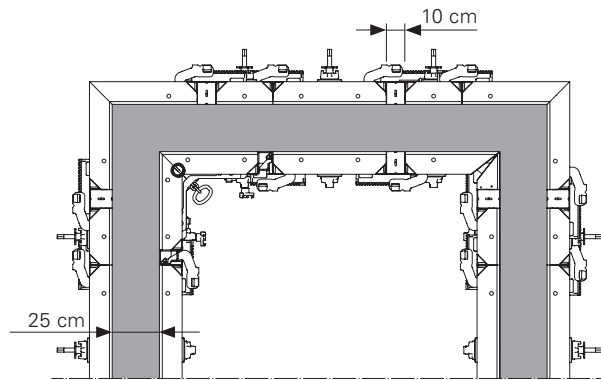

struck

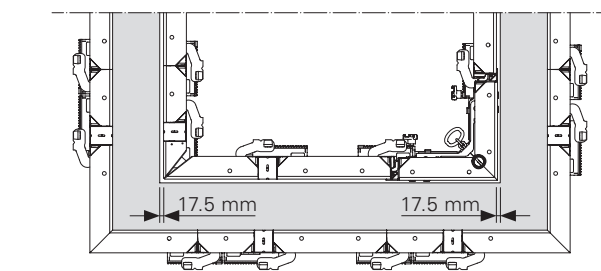
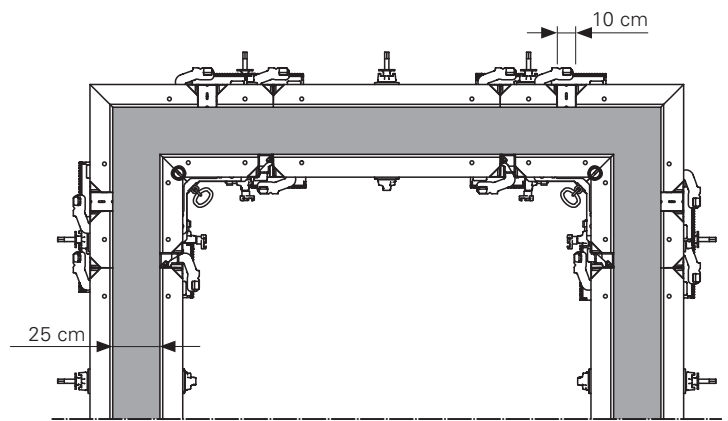

Fig. D5.10

Shaft with four Shaft Corners MXSE 18

The striking dimensions are reduced by 35 mm on each side of the shaft. (Fig. D5.11)

shuttered



struck

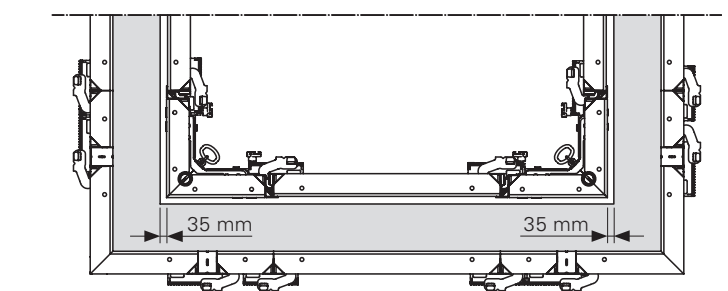

Fig. D5.11

Wall Thicknesses



Dimension specifications in mm.

Wall thickness 150

(Fig. D5.12a + D5.12b)

Shaft with
two Shaft Corners MXSE 18

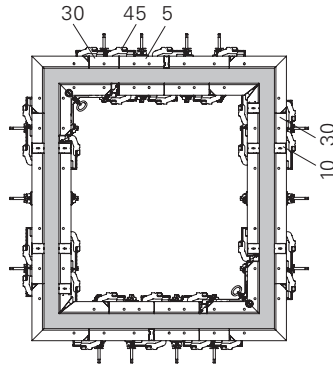

Fig. D5.12a

Shaft with
four Shaft Corners MXSE 18

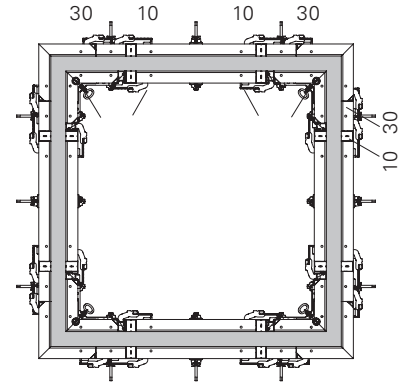

Fig. D5.12b

Wall thickness 200

(Fig. D5.13a + D5.13b)

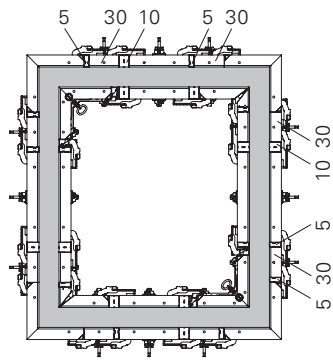

Fig. D5.13a

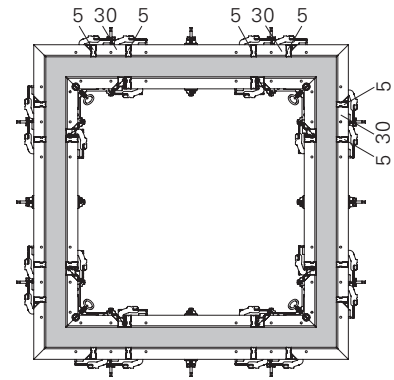

Fig. D5.13b

Wall thickness 250

(Fig. D5.14a + D5.14b)

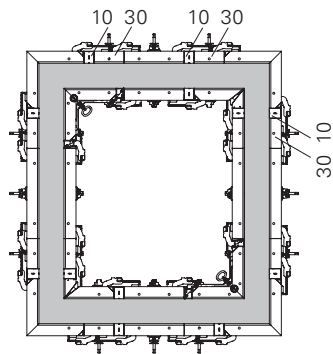

Fig. D5.14a

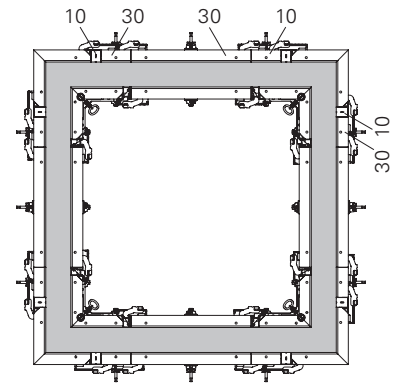

Fig. D5.14b

Wall thickness 300

(Fig. D5.15a + D5.15b)

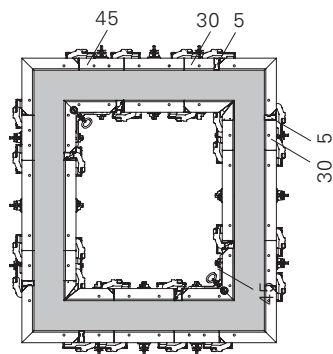

Fig. D5.15a

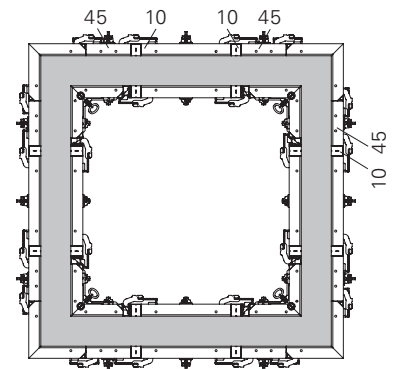

Fig. D5.15b

Extensions

(Fig. D5.16 + D5.16a + D5.16b + D5.16c)

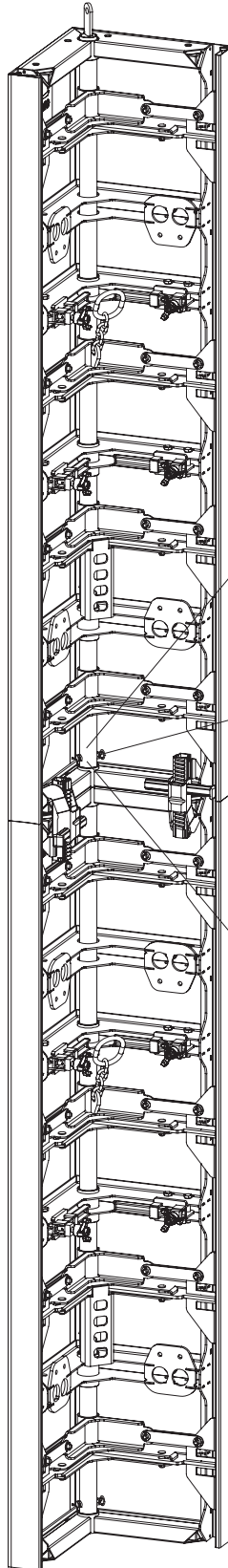

Fig. D5.16

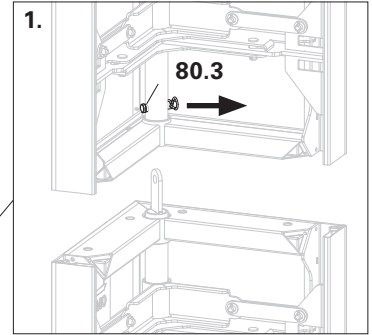

Fig. D5.16a

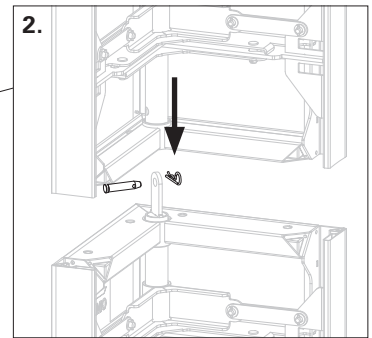

Fig. D5.16b

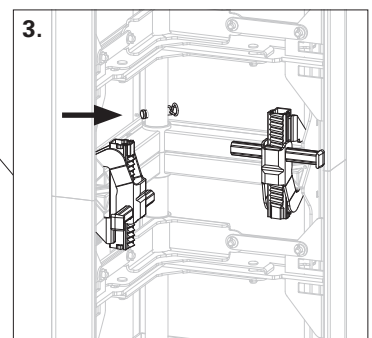

Fig. D5.16c

Removing the sealing

Prepare the Removable Tool MX

Turn back Removable Tool MX (95).
(Fig. D6.01)

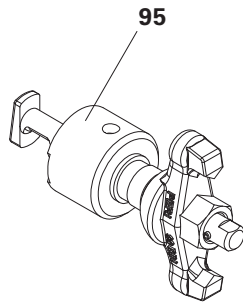

Fig. D6.01

Starting position on the panel

Replacement of Sealing MX 18 or modification to Sealing MX 15 (10.1).
(Fig. D6.02)

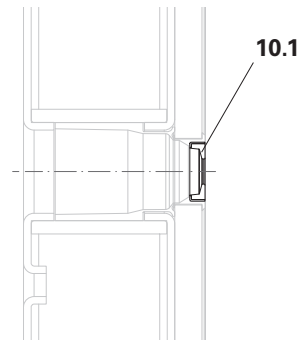

Fig. D6.02

Using the Removable Tool MX

1. Screw in the Extraction Head (95.1) with the thick end at an angle into the sealing until the Extraction Head is positioned inside the sealing.
(Fig. D6.03a + D6.03b)
2. Turn the Removable Tool MX towards the panel until the Extractor Bell (95.2) rests against it. (Fig. D6.04a)
3. Secure the Extractor Bell and continue turning until the sealing is released.
4. Screw out the Extraction Head from the sealing. (Fig. D6.04b)

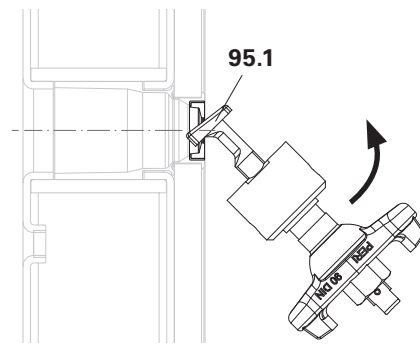

Fig. D6.03a

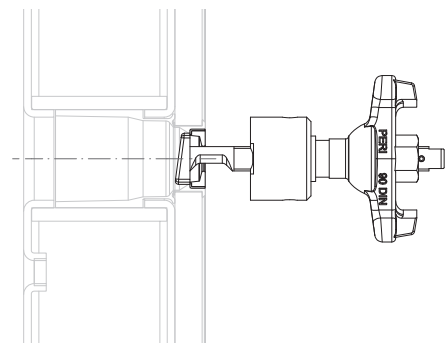

Fig. D6.03b

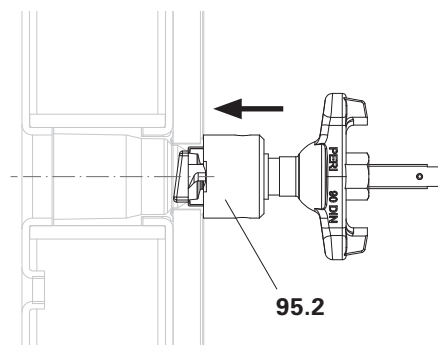

Fig. D6.04a

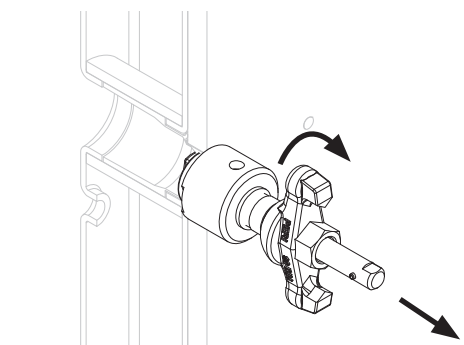

Fig. D6.04b

Inserting the sealing

Inner side of panel

1. Place new sealing on the opening.
(Fig. D6.05a)
2. Install sealing using hammer and plate until flush fit is achieved.
(Fig. D6.05b)

→ The sealing has now been replaced.
(Fig. D6.06)

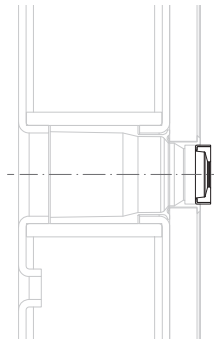

Fig. D6.05a

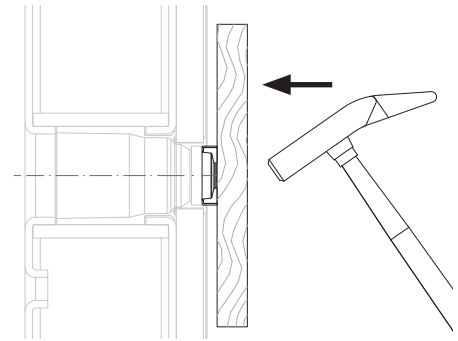

Fig. D6.05b

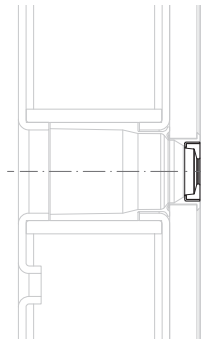

Fig. D6.06

MAXIMO MX 18 Panel Formwork 270 / 330



Item no.	Weight kg
124093	408,000

Panel MX 18, 330 x 240
7.920 m². Panel with 18 mm plywood.

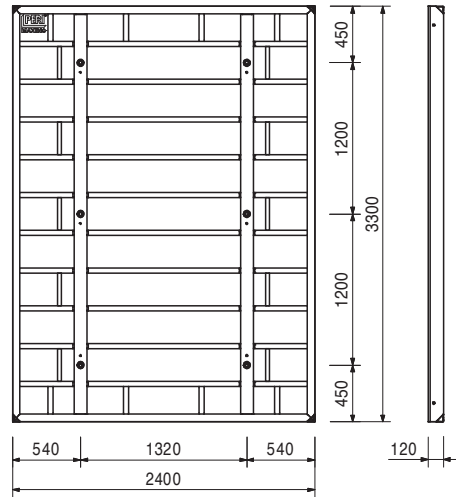
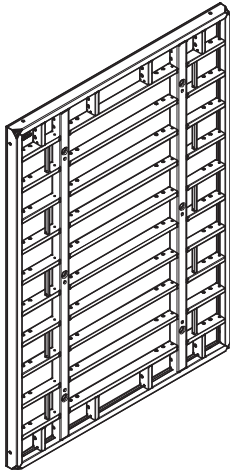

124126	226,000
--------	---------

Panel MX 18, 330 x 120
3.960 m². Panel with 18 mm plywood.

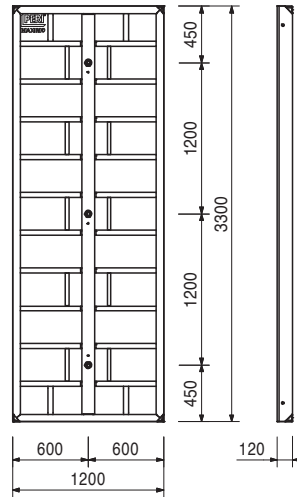
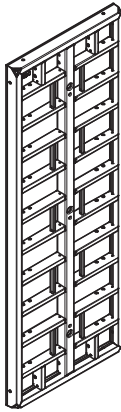

124127	172,000
--------	---------

Panel MX 18, 330 x 90
2.970 m². Panel with 18 mm plywood.

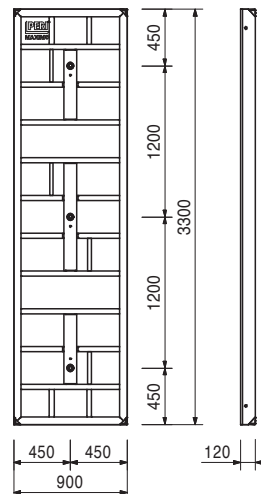
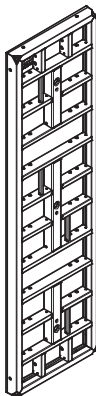

MAXIMO MX 18 Panel Formwork 270 / 330



Item no.	Weight kg
124128	118,000

Panel MX 18, 330 x 60
1.980 m². Panel with 18 mm plywood.

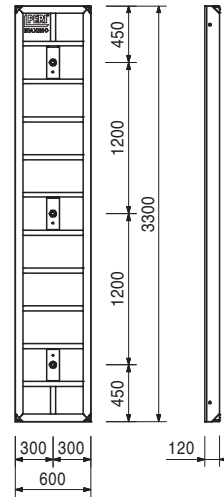
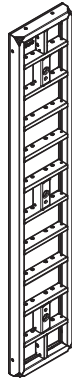

124129	99,900
--------	--------

Panel MX 18, 330 x 45
1.485 m². Panel with 18 mm plywood.

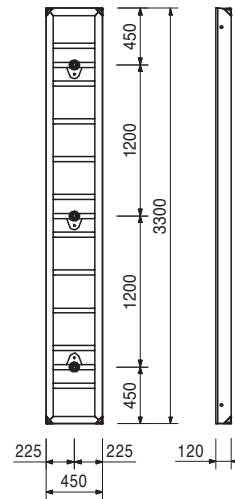

124130	79,600
--------	--------

Panel MX 18, 330 x 30
0.990 m². Panel with 18 mm plywood.

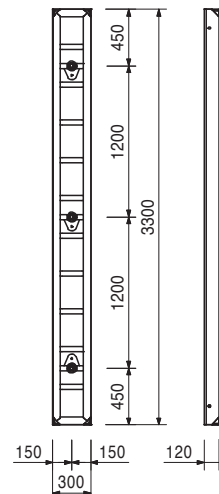

MAXIMO MX 18 Panel Formwork 270 / 330



Item no.	Weight kg
124163	141,000

Multi Panel MXM 18, 330 x 60
 1.980 m². Panel with 18 mm plywood.
 For oblique angles, wall connections etc.

Complete with
 33 pc. 125099 Plug MXM 18, Ø 26
 33 pc. 123604 Sealing MX 18

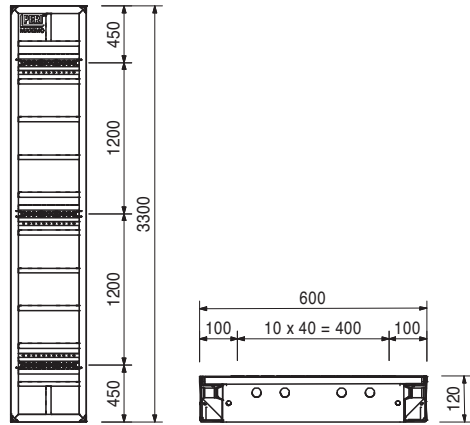

124190	136,000
--------	---------

Inside Corner MXI 18, 330 x 50/20
 2.310 m². Panel with 18 mm plywood.
 For 90° internal corner.

Complete with
 12 pc. 125099 Plug MXM 18, Ø 26
 12 pc. 123604 Sealing MX 18

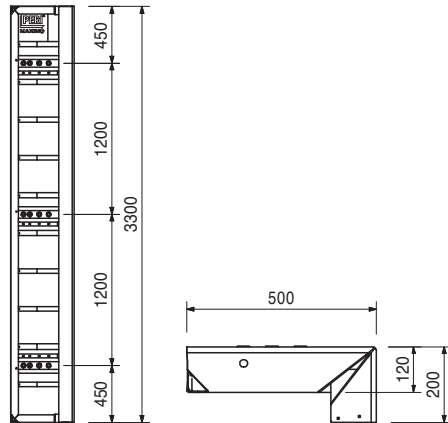

124195	206,000
--------	---------

Inside Corner MXI 18, 330 x 60
 3.960 m². Panel with 18 mm plywood.
 For 90° internal corners.

Complete with

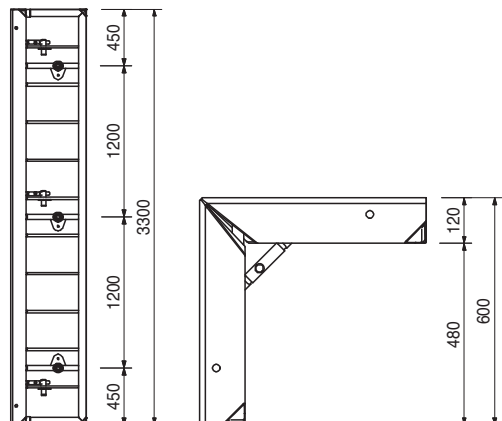
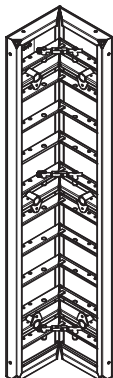

MAXIMO MX 18 Panel Formwork 270 / 330



Item no.	Weight kg
125284	401,000

Shaft Corner MXSE 18, 330

Panel for forming 90° inside corners along with striking and moving complete internal shaft formwork units.

Complete with

4 pc. 126263 Position Latch MXSE.

Technical Data

Permissible load-bearing point capacity 2.0 t.

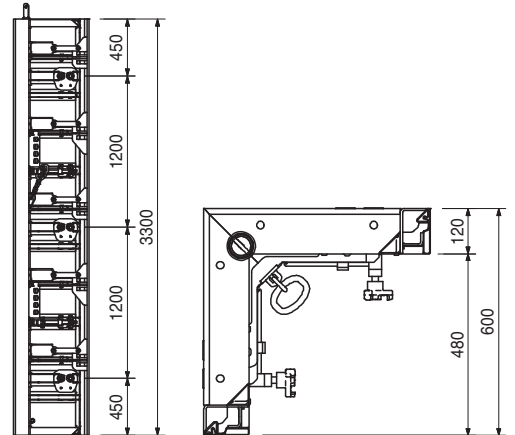

114478	192,000
--------	---------

Outside Corner MXA 330 x 45

2.970 m². Panel with 18 mm plywood.
For 90° external corners.

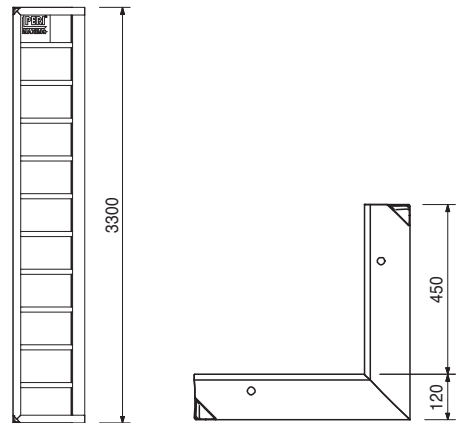

114486	170,000
--------	---------

Outside Corner MXA 330 x 35

2.310 m². Panel with 18 mm plywood.
For 90° external corners.

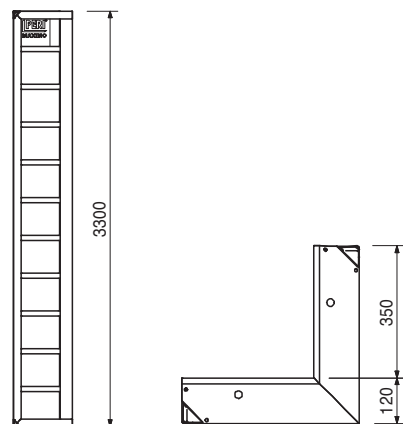
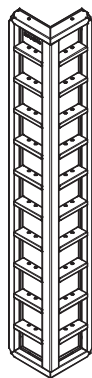

MAXIMO MX 18 Panel Formwork 270 / 330



Item no.	Weight kg		B
114842	17,800	Wall Thickness Compensations WDA MX 330	40
114826	18,900	Wall Thickness Comp. WDA MX 330 x 4	50
114846	20,200	Wall Thickness Comp. WDA MX 330 x 6	60
114394	12,100	Wall Thickness Comp. WDA MX 330 x 10, Alu	100

For adjusting to wall thicknesses.

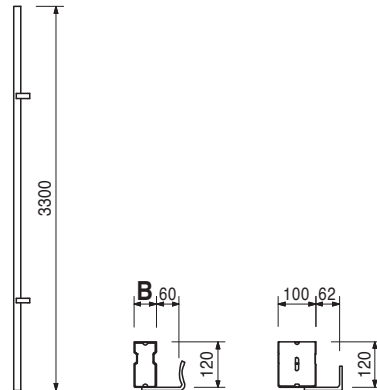

101829	9,820	Filler Profile TPP 330, Alu For compensation with 21 mm filler plates.
--------	-------	--

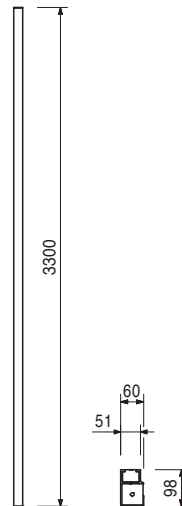

124131	446,000	Panel MX 18, 330 x 270 8.910 m ² . Panel with 18 mm plywood.
--------	---------	---

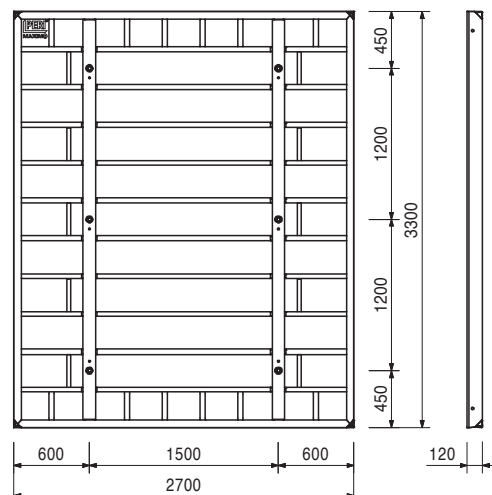
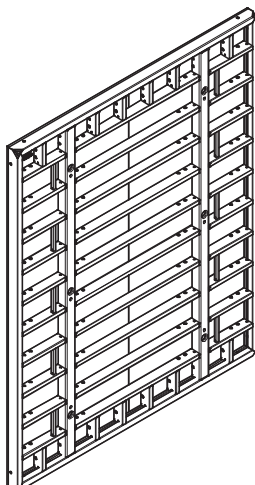

MAXIMO MX 18 Panel Formwork 270 / 330



Item no.	Weight kg
124132	336,000

Panel MX 18, 270 x 240
6.480 m². Panel with 18 mm plywood.

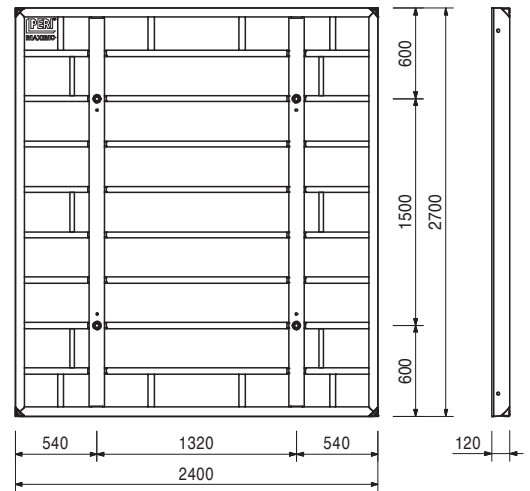
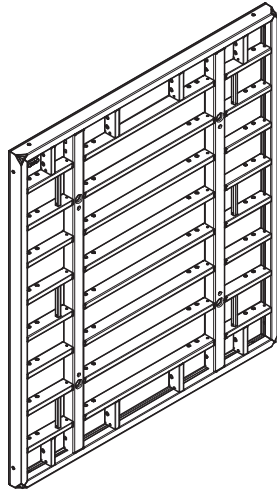

124134	186,000
--------	---------

Panel MX 18, 270 x 120
3.240 m². Panel with 18 mm plywood.

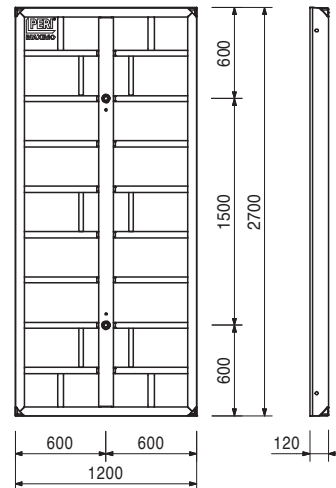
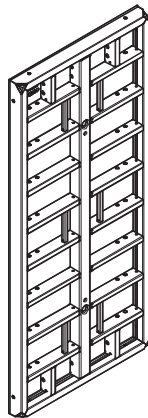

124138	135,000
--------	---------

Panel MX 18, 270 x 90
2.430 m². Panel with 18 mm plywood.

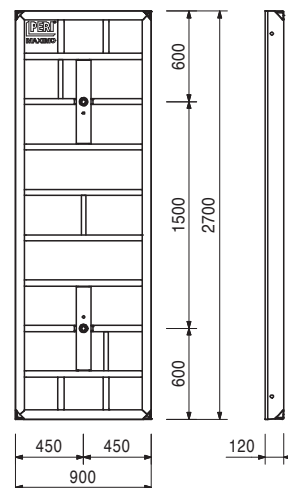
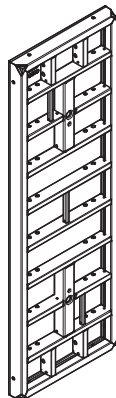

MAXIMO MX 18 Panel Formwork 270 / 330



Item no. Weight kg

124135 104,000

Panel MX 18, 270 x 60

1.620 m². Panel with 18 mm plywood.

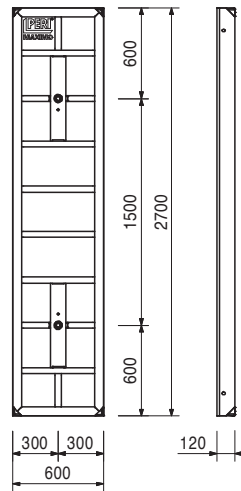
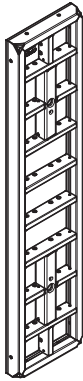

124136 77,600

Panel MX 18, 270 x 45

1.215 m². Panel with 18 mm plywood.

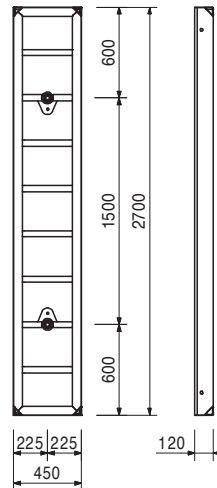

124137 62,800

Panel MX 18, 270 x 30

0.810 m². Panel with 18 mm plywood.

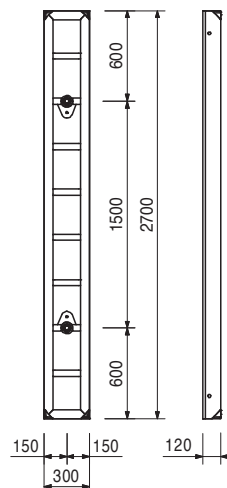

MAXIMO MX 18 Panel Formwork 270 / 330



Item no.	Weight kg
124188	108,000

Multi Panel MXM 18, 270 x 60

1.620 m². Panel with 18 mm plywood.
For oblique angles, wall connections etc.

Complete with

22 pc. 125099 Plug MXM 18, Ø 26
22 pc. 123604 Sealing MX 18

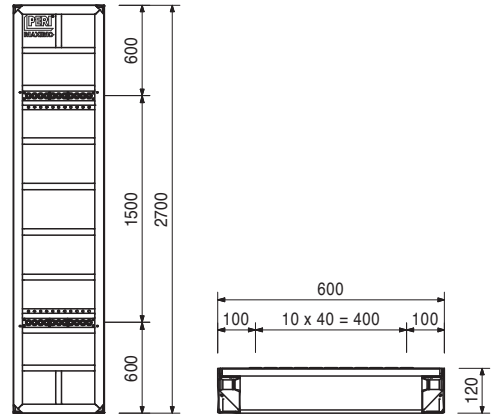
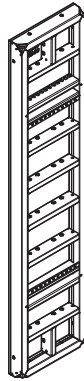

124191	103,000
--------	---------

Inside Corner MXI 18, 270 x 50/20

1.890 m². Panel with 18 mm plywood.
For 90° internal corner.

Complete with

8 pc. 125099 Plug MXM 18, Ø 26
8 pc. 123604 Sealing MX 18

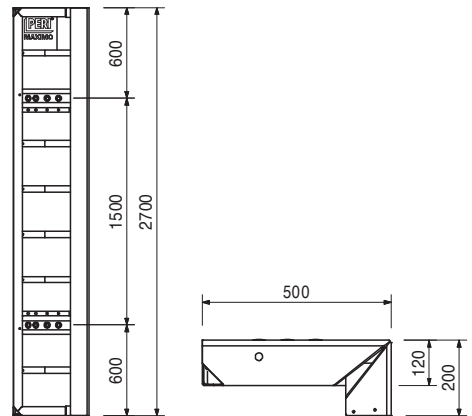
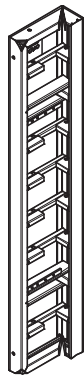

124196	156,000
--------	---------

Inside Corner MXI 18, 270 x 60

3.240 m². Panel with 18 mm plywood.
For 90° internal corners.

Complete with

8 pc. 125099 Plug MXM 18, Ø 26
8 pc. 123604 Sealing MX 18

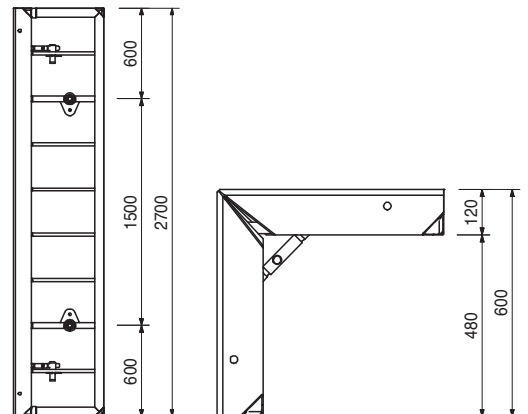
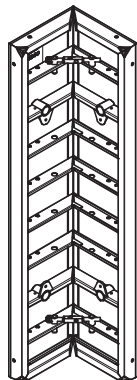

MAXIMO MX 18 Panel Formwork 270 / 330



Item no.	Weight kg
125286	306,000

Shaft Corner MXSE 18, 270

Panel for forming 90° inside corners along with striking and moving complete internal shaft formwork units.

Complete with

4 pc. 126263 Position Latch MXSE.

Technical Data

Permissible load-bearing point capacity 2.0 t.

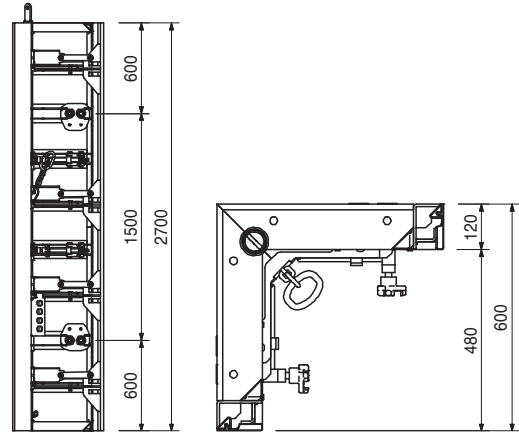
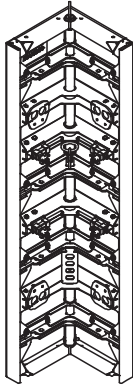

112806	159,000
--------	---------

Outside Corner MXA 270 x 45

2.430 m². Panel with 18 mm plywood.
For 90° external corners.

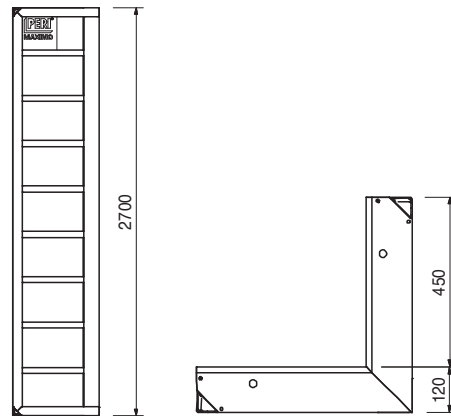
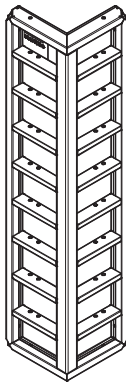

112667	141,000
--------	---------

Outside Corner MXA 270 x 35

1.890 m². Panel with 18 mm plywood.
For 90° external corners.

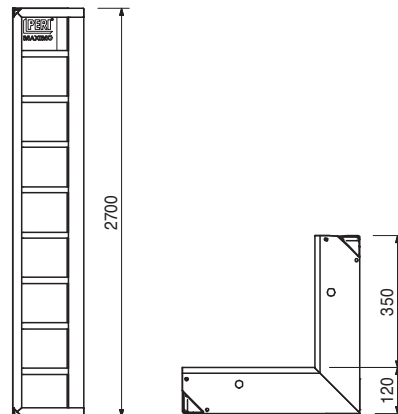
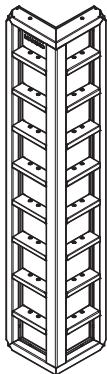

MAXIMO MX 18 Panel Formwork 270 / 330

Item no.	Weight kg		B
114165	14,700	Wall Thickness Compensations WDA MX 270	
		Wall Thickness Comp. WDA MX 270 x 4	40
114186	15,700	Wall Thickness Comp. WDA MX 270 x 5	50
114174	16,800	Wall Thickness Comp. WDA MX 270 x 6	60
114128	10,000	Wall Thickness Comp. WDA MX 270 x 10, Alu	100

For adjusting to wall thicknesses.

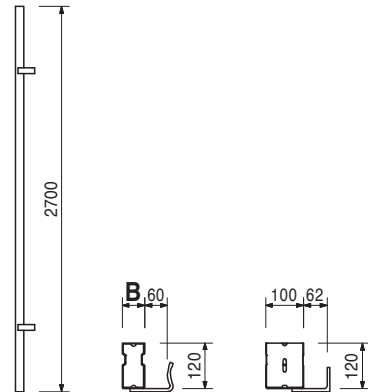

101813	8,040	Filler Profile TPP 270, Alu	
For compensation with 21 mm filler plates.			

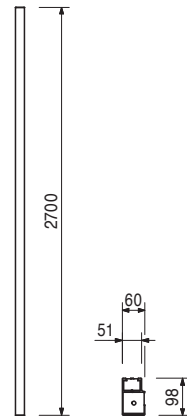

			B
023061	27,500	Stoepend Panels TRIO MT without waterstop	
		Stoepend Panel TRIO MT 270 x 20	118
023062	30,400	Stoepend Panel TRIO MT 270 x 24/25	158
023064	37,300	Stoepend Panel TRIO MT 270 x 30	218
023065	41,300	Stoepend Panel TRIO MT 270 x 35/36	268

Centre piece without waterstop bar installation for stoepend formwork.

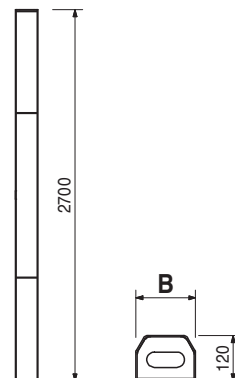

MAXIMO MX 18 Panel Formwork 270 / 330



Item no.	Weight kg		B
023074	29,200	Stopend Panels TRIO MTF with waterstop	118
023075	33,400	Stopend Panel TRIO MTF 270 x 20	158
023077	38,600	Stopend Panel TRIO MTF 270 x 24/25	218
023076	42,500	Stopend Panel TRIO MTF 270 x 30	268
		Stopend Panel TRIO MTF 270 x 35/36	
		Centre piece with waterstop bar installation for stopend formwork.	

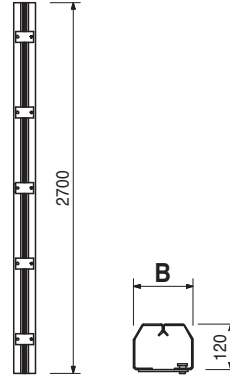

023060	17,200	Stopend Panels TRIO AT	Note Concrete cover approx. 30 or 50 mm.
105953	19,000	Stopend Panel TRIO AT 270 x 3	
		Stopend Panel TRIO AT 270 x 5	
		External piece for stopend formwork.	

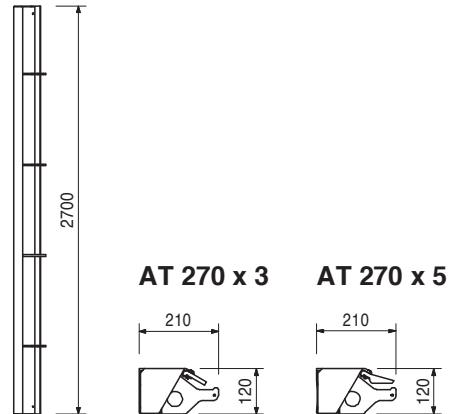

124139	166,000	Panel MX 18, 120 x 240
		2.880 m ² . Panel with 18 mm plywood.

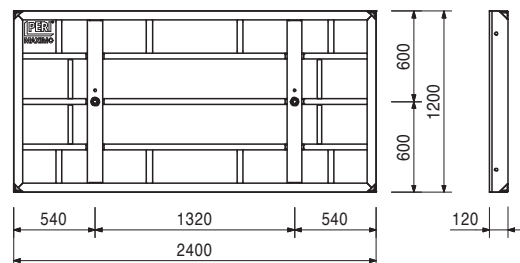
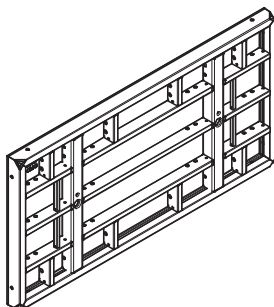

MAXIMO MX 18 Panel Formwork 270 / 330



Item no. Weight kg

124142 90,700

Panel MX 18, 120 x 120

1.440 m². Panel with 18 mm plywood.

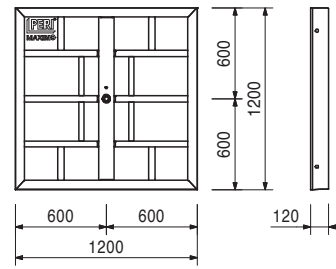
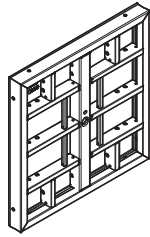

124143 67,700

Panel MX 18, 120 x 90

1.080 m². Panel with 18 mm plywood.

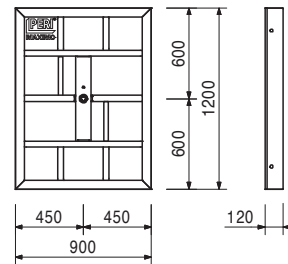
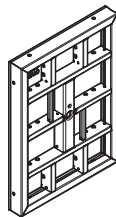

124144 51,200

Panel MX 18, 120 x 60

0.720 m². Panel with 18 mm plywood.

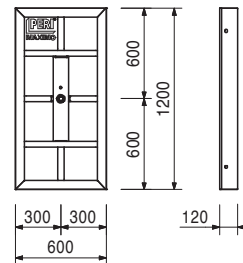

124145 37,100

Panel MX 18, 120 x 45

0.540 m². Panel with 18 mm plywood.

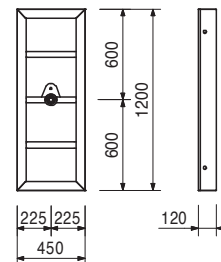

Item no.	Weight kg
124146	27,400

Panel MX 18, 120 x 30
0.360 m². Panel with 18 mm plywood.

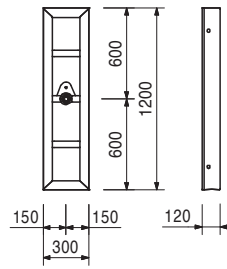

124189	53,700
--------	--------

Multi Panel MXM 18, 120 x 60
0.720 m². Panel with 18 mm plywood.
For oblique angles, wall connections etc.

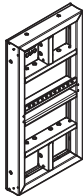

Complete with

11 pc. 125099 Plug MXM 18, Ø 26
11 pc. 123604 Sealing MX 18

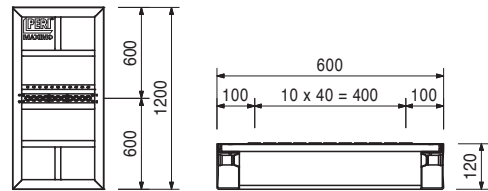

125277	48,800
--------	--------

Inside Corner MXI 18, 120 x 50/20
0.840 m². Panel with 18 mm plywood.
For 90° internal corners.

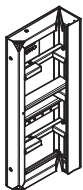

Complete with

4 pc. 125099 Plug MXM 18, Ø 26
4 pc. 123604 Sealing MX 18

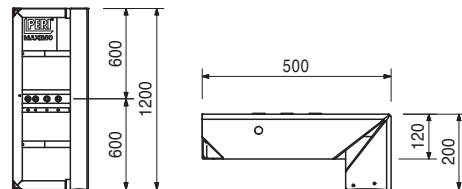

124197	80,500
--------	--------

Inside Corner MXI 18, 120 x 60
1.440 m². Panel with 18 mm plywood.
For 90° internal corners.

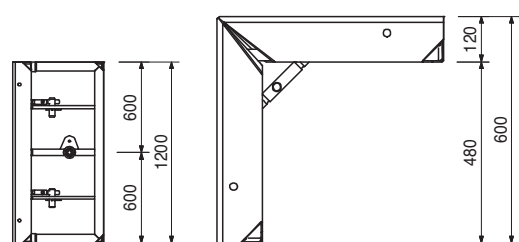
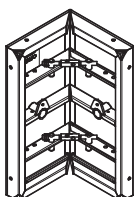

MAXIMO MX 18 Panel Formwork 270 / 330



Item no.	Weight kg
125288	139,000

Shaft Corner MXSE 18, 120

For 90° inside corners along with striking and moving complete internal shaft formwork units.

Technical Data

Permissible load-bearing point capacity 2.0 t.

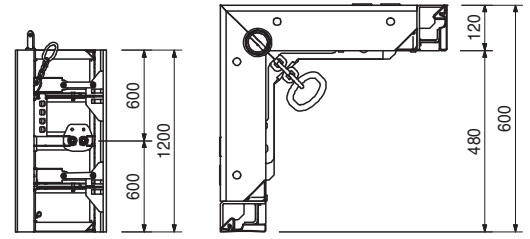
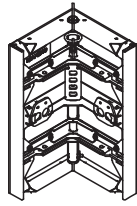

112830	76,100
--------	--------

Outside Corner MXA 120 x 45

1.080 m². Panel with 18 mm plywood.
For 90° external corners.

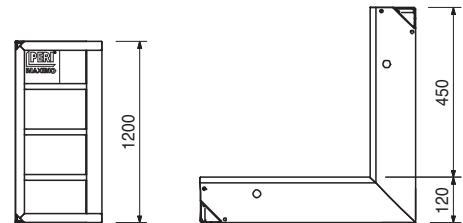

112761	67,200
--------	--------

Outside Corner MXA 120 x 35

0.840 m². Panel with 18 mm plywood.
For 90° external corners.

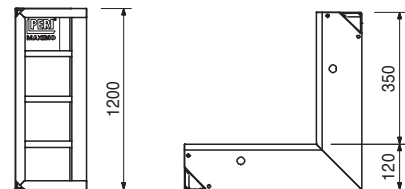
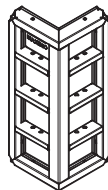

114212	6,420	Wall Thickness Comp. MX 120	B
114191	6,980	Wall Thickness Comp. MX 120 x 4	40
114181	7,480	Wall Thickness Comp. MX 120 x 5	50
114142	4,510	Wall Thickness Comp. MX 120 x 6	60
		Wall Thickness Comp. MX 120 x 10, Alu	100

For adjusting to wall thicknesses.

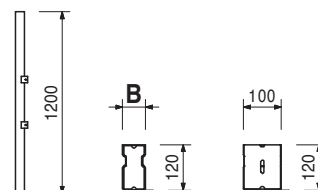

Item no.	Weight kg
101823	3,590

Filler Profile TPP 120, Alu
For compensation with 21 mm filler plates.

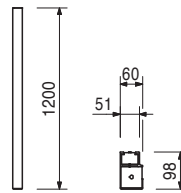

023067	7,780
105978	8,580

Stopend Panels TRIO AT
Stopend Panel TRIO AT 120 x 3
Stopend Panel TRIO AT 120 x 5
External piece for stopend formwork.

Note
Concrete cover approx. 30 mm.

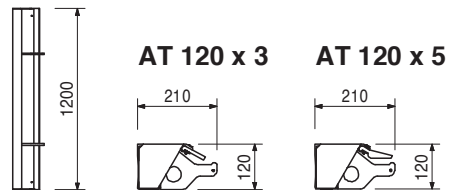

023068	11,800
023069	13,500
023071	16,300
023072	18,500

Stopend Panels TRIO MT
Stopend Panel TRIO MT 120 x 20
Stopend Panel TRIO MT 120 x 24/25
Stopend Panel TRIO MT 120 x 30
Stopend Panel TRIO MT 120 x 35/36
Centre piece without waterstop bar installation for stopend formwork.

B
118
158
218
268

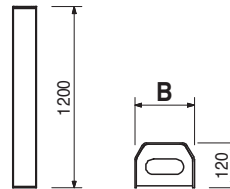

023081	12,800
023080	14,700
023078	16,800
023079	18,600

Stopend Panels TRIO MTF
Stopend Panel TRIO MTF 120 x 20
Stopend Panel TRIO MTF 120 x 24/25
Stopend Panel TRIO MTF 120 x 30
Stopend Panel TRIO MTF 120 x 35/36
Centre piece with waterstop bar installation for stopend formwork.

B
118
158
218
268

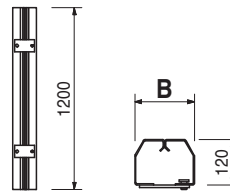

MAXIMO MX 18 Panel Formwork 270 / 330



Item no.	Weight kg
124147	121,000

Panel MX 18, 90 x 240
2.160 m². Panel with 18 mm plywood.

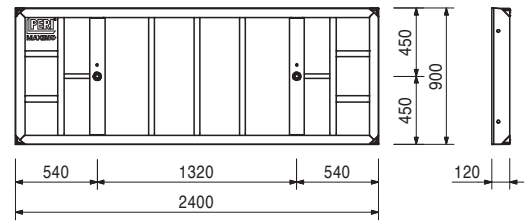
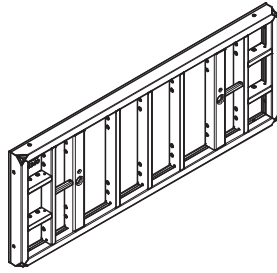

124148	48,900
--------	--------

Panel MX 18, 90 x 90
0.810 m². Panel with 18 mm plywood.

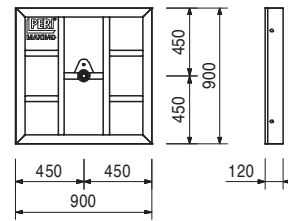
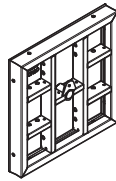

124149	36,600
--------	--------

Panel MX 18, 90 x 60
0.540 m². Panel with 18 mm plywood.

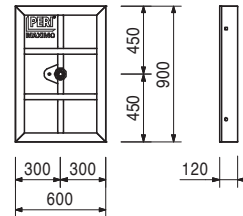
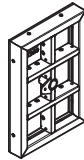

124150	31,200
--------	--------

Panel MX 18, 90 x 45
0.405 m². Panel with 18 mm plywood.

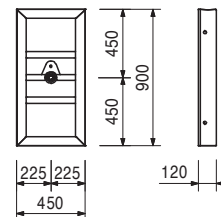

MAXIMO MX 18 Panel Formwork 270 / 330



Item no.	Weight kg
124151	22,000

Panel MX 18, 90 x 30
0.270 m². Panel with 18 mm plywood.

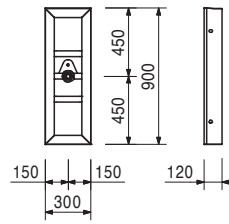

124192	36,900
--------	--------

Inside Corner MXI 18, 90 x 50/20
0.630 m². Panel with 18 mm plywood.
For 90° internal corners.

Complete with
4 pc. 125099 Plug MXM 18, Ø 26
4 pc. 123604 Sealing MX 18

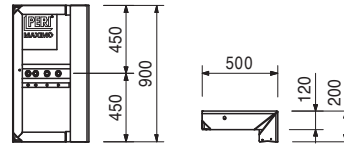

124198	68,100
--------	--------

Inside Corner MXI 18, 90 x 60
1.080 m². Panel with 18 mm plywood.
For 90° internal corners.

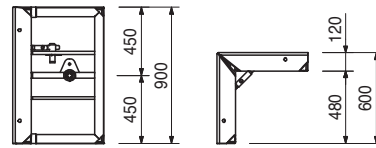
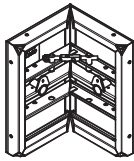

126917	52,400
--------	--------

Outside Corner MXA 90 x 35
0.630 m². Panel with 18 mm plywood. For 90° external corners.

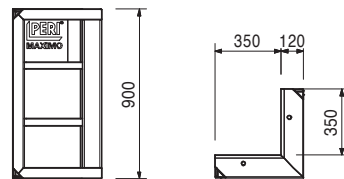

MAXIMO MX 18 Panel Formwork 270 / 330



Item no.	Weight kg
126923	59,600

Outside Corner MXA 90 x 45

0.808 m². Panel with 18 mm plywood. For 90° external corners.

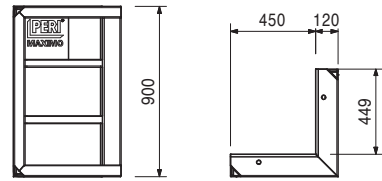
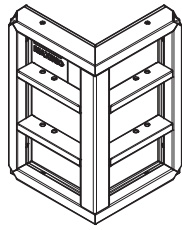

124157	88,100
--------	--------

Panel MX 18, 60 x 240

1.440 m². Panel with 18 mm plywood.

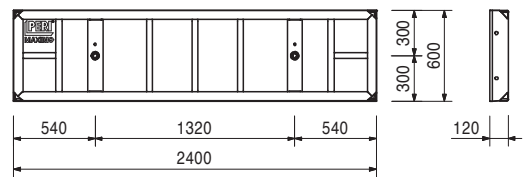
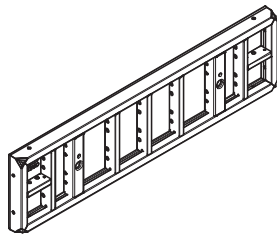

124158	28,400
--------	--------

Panel MX 18, 60 x 60

0.360 m². Panel with 18 mm plywood.

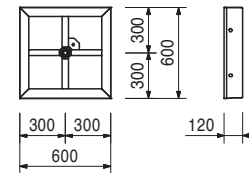

124160	21,900
--------	--------

Panel MX 18, 60 x 45

0.270 m². Panel with 18 mm plywood.

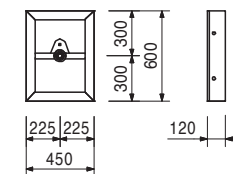

124159	16,200
--------	--------

Panel MX 18, 60 x 30

0.180 m². Panel with 18 mm plywood.

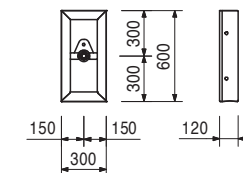

MAXIMO MX 18 Panel Formwork 270 / 330



Item no.	Weight kg
124193	29,700

Inside Corner MXI 18, 60 x 50/20
 0.420 m². Panel with 18 mm plywood.
 For 90° internal corners.

Complete with
 4 pc. 124895 PVC Plug MXM 15 Ø 18.3
 4 pc. 123604 Sealing MX 18

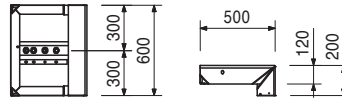

124199	45,400
--------	--------

Inside Corner MXI 18, 60 x 60
 0.720 m². Panel with 18 mm plywood.
 For 90° internal corners.

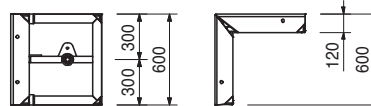
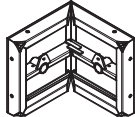

112837	42,800
--------	--------

Outside Corner MXA 60 x 45
 0.540 m². Panel with 18 mm plywood.
 For 90° external corners.

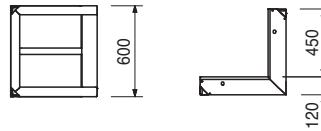

112778	37,400
--------	--------

Outside Corner MXA 60 x 35
 0.420 m². Panel with 18 mm plywood.
 For 90° external corners.

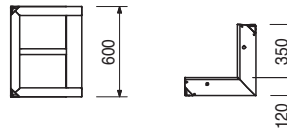

124162	52,900
--------	--------

Panel MX 18, 30 x 240
 0.720 m². Panel with 18 mm plywood.

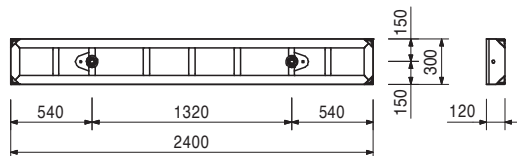
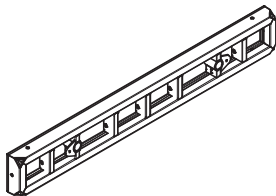

MAXIMO MX 18 Panel Formwork 270 / 330



Item no.	Weight kg			
123901	4,880	Tie MX 18, 15 – 25 For wall thicknesses 15 – 25 cm.	Note Spray with release agent before every use to ensure easier striking. Technical Data Permissible tension force 130 kN.	
123902	5,080	Tie MX 18, 20 – 30 For wall thicknesses 20 – 30 cm.	Note Spray with release agent before every use to ensure easier striking. Technical Data Permissible tension force 130 kN.	
123903	5,490	Tie MX 18, 30 – 40 For wall thicknesses 30 – 40 cm.	Note Spray with release agent before every use to ensure easier striking. Technical Data Permissible tension force 130 kN.	
123904	5,900	Tie MX 18, 40 – 50 For wall thicknesses 40 – 50 cm.	Note Spray with release agent before every use to ensure easier striking. Technical Data Permissible tension force 130 kN.	

Item no.	Weight kg
123905	6,310

Tie MX 18, 50 – 60
For wall thicknesses 50 – 60 cm.

Note
Spray with release agent before every use to ensure easier striking.

Technical Data
Permissible tension force 130 kN.

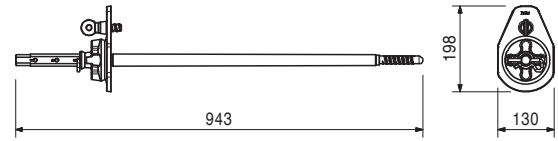
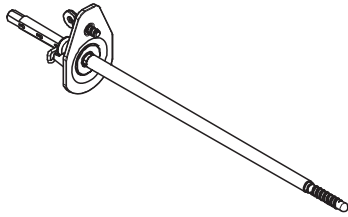

123900	3,570
--------	-------

Wingnut MX 18
Counter nut for Tie MX 18.

Technical Data
Permissible tension force 130 kN.

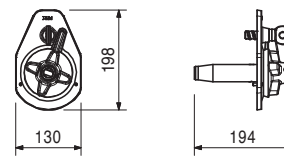

108719	3,640
--------	-------

Tie Rod Spanner TRH SW 22
For Anchor TRH.

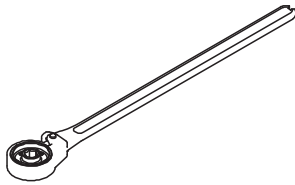
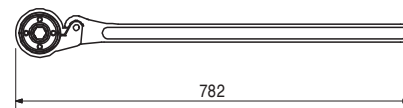

796061	3,940
--------	-------

Scaffold Builders Ratchet

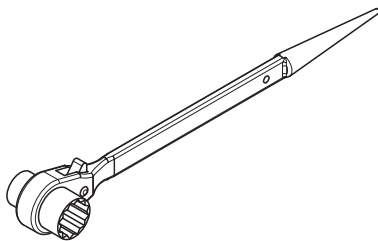
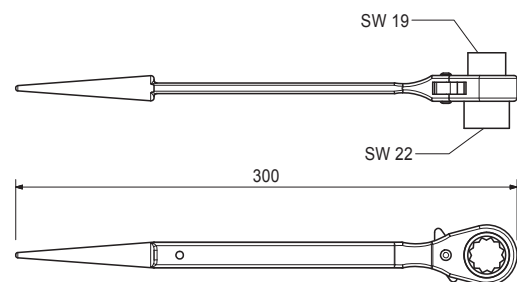

Item no.	Weight kg
125099	0,005

Plug MXM 18, Ø 26

For MAXIMO Multi Panels MXM 18, Internal Corners MXI 18 50/20 and standard elements for single faced use.

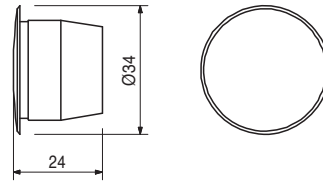
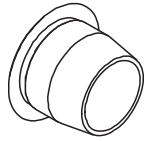

125300	0,003
--------	-------

Plug MX 18, Ø 24 – 28

For closing MX 18 tie holes in the concrete.

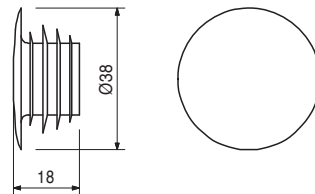

023500	4,580
--------	-------

Alignment Coupler BFD, galv.

For all panel connections for MAXIMO, TRIO and RUNDFLEX. Fillers up to 10 cm.

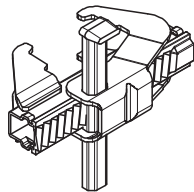

Technical Data

Permissible tension force 20.0 kN.

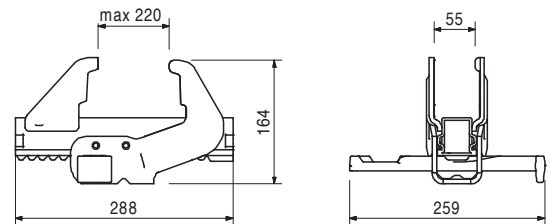

124941	14,100
--------	--------

Waler MAR 85-3

For longitudinal compensation, height extensions, stopend formwork and special applications with MAXIMO. With captive connecting components.

Technical Data

Permissible bending moment 3.9 kNm.

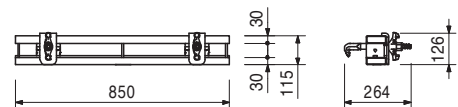
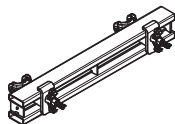

Item no.	Weight kg
124942	23,400

Waler MAR 170-3

For longitudinal compensation, height extensions, stopend formwork and special applications with MAXIMO. With captive connecting components.

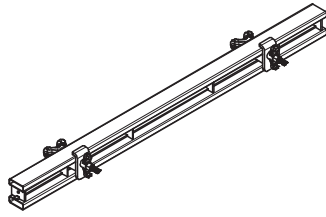

Technical Data

Permissible bending moment 3.9 kNm.

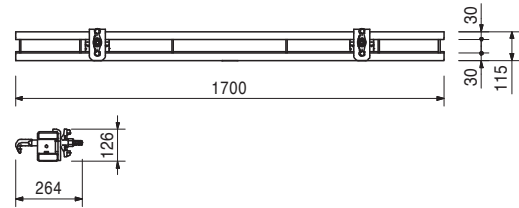

023551	8,520
--------	-------

Waler 85

Corresponds to Compensation Waler TAR 85 but without mounting hooks.

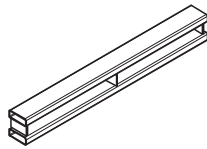

Technical Data

Permissible bending moment 4.4 kNm.

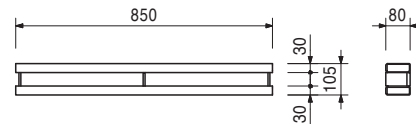

023820	0,375
--------	-------

Hook Tie Head DW 15, galv.

For connecting accessories to MAXIMO and TRIO panels. DW 15 thread.



Technical Data

Permissible tension force 20.0 kN.

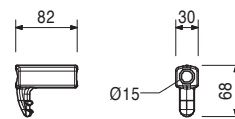

023650	0,769
--------	-------

Hook Tie DW 15, l = 400 mm, galv.

For connecting accessories to MAXIMO and TRIO panels. DW 15 thread.

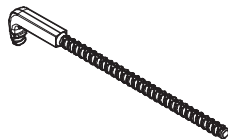

Technical Data

Permissible tension force 20.0 kN.

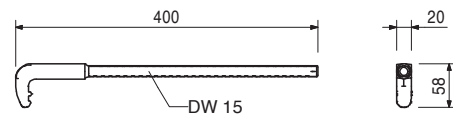

023640	1,140
--------	-------

Bulkhead Tie TS, galv.

For force application from the stopend formwork in MAXIMO and TRIO panels. DW 15 thread.

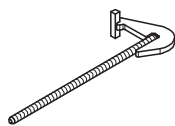

Technical Data

Permissible tension force 20.0 kN.

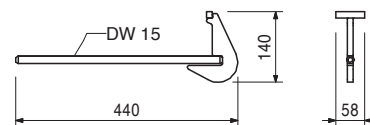

Item no.	Weight kg
115640	5,980

Bulkhead Tie MX DW 20

For forming wall offsets with MAXIMO in connection with the Multi Panel MXM.

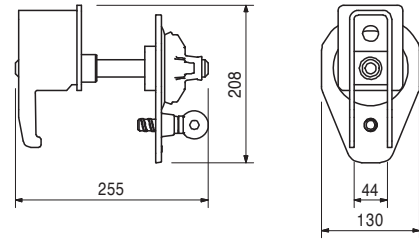
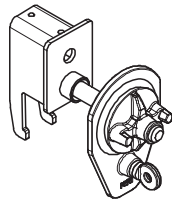

023660	3,300
--------	-------

Brace Connector TRIO, galv.

For connecting push-pull props and kicker braces to MAXIMO and TRIO Panels. Mounted on vertical and horizontal struts.

Complete with

- 1 pc. 027170 Pin Ø 16 x 42, galv.
- 1 pc. 018060 Cotter Pin 4/1, galv.

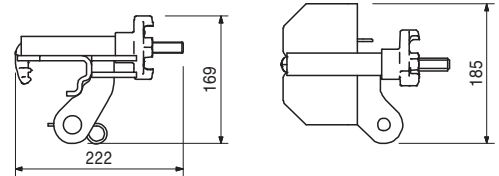
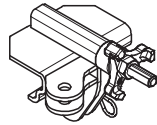

115350	6,330
123842	9,090

Tension and Compression Braces MX

Tension and Compression Brace MX 15 – 40

Tension and Compression Brace MX 15 – 100

For use with foundation formwork up to 1.20 m high and as replacement for the top anchor of the MAXIMO 330.

Complete with

- 1 pc. 115331 Bolt Ø 12 x 96, galv.
- 1 pc. 018060 Cotter Pin 4/1, galv.

Note

Adjustable in 0.5-cm-increments from 15 to 40 cm and in 0.5-cm-increments from 15 to 100 cm.

Technical Data

Permissible tension and compressive force 9 kN.

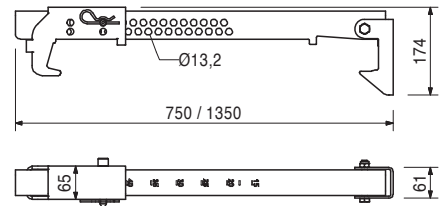
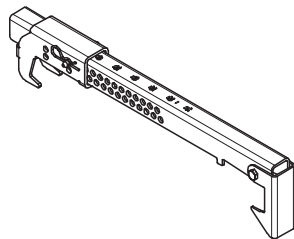

112588	5,520
--------	-------

Stripping Bar TRIO

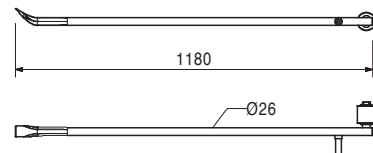
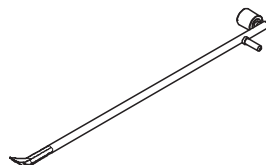

Item no.	Weight kg
101633	9,790

Adjusting Bracket MX

For erecting PERI Panel Formwork up to h = 4.50 m.

Note

Follow Instructions for Use!
Height Adjustment \pm 5 cm.

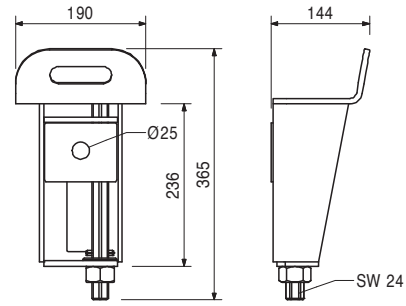
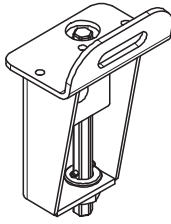

023630	2,080
--------	-------

Top Tie Bracket-2 AH, galv.

For grid-independent anchoring outside of the panel, especially for foundations and height extensions.

Technical Data

Permissible anchor tension force:
Hole 1 = 30 kN
Hole 2 = 15 kN

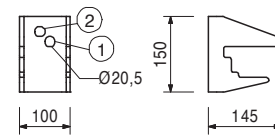
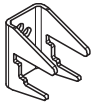

117321	31,000
--------	--------

Lifting Gear Combi MX

For transporting stacks of MAXIMO and TRIO Panels. For attaching Lifting Hook MAXIMO 1.5 t and Stacking Device MAXIMO.

Note

Follow Instructions for Use!

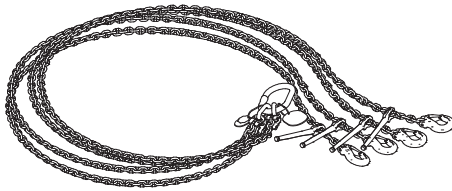

117322	25,000
--------	--------

Lifting Gear MX

For transporting stacks of MAXIMO and TRIO Panels.

Note

Follow Instructions for Use!

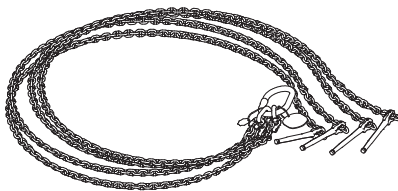

MAXIMO MX 18 Panel Formwork 270 / 330

Item no.	Weight kg
115168	7,470

Lifting Hook MAXIMO 1.5 t
For transporting MAXIMO and TRIO Panels.

Note
Follow Instructions for Use!
Technical Data
Permissible load-bearing capacity:
Steel elements 1.5 t
Alu elements 750 kg

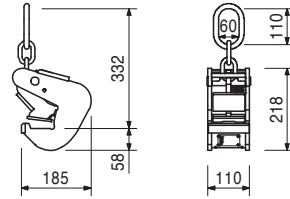
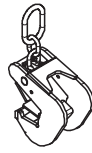

115058	7,450
--------	-------

Stacking Device MAXIMO
For stacking and transportation of 2 – 5 MAXIMO or TRIO Panels of all sizes. Suitable for crane and fork-lift transport.

Note
Follow Instructions for Use!
Technical Data
Permissible load-bearing capacity 650 kg per post, 2.6 t per stack.

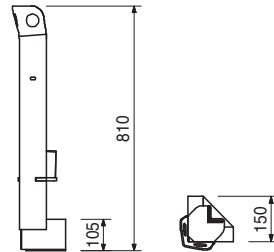
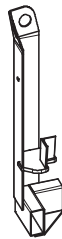

113019	0,068
--------	-------

Stacking Device MX
For easy stacking of MAXIMO panels.

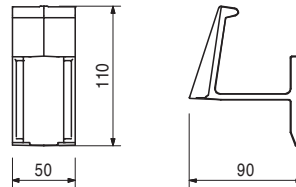
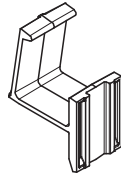

023440	0,312
--------	-------

Lifting Pin TRIO
For easy carrying of TRIO Panels.

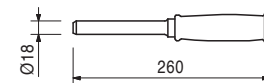
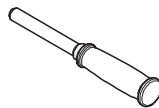

MAXIMO MX 18 Panel Formwork 270 / 330



Item no.	Weight kg
023670	12,800
023680	17,000

Scaffold Brackets TRG Scaffold Bracket TRG 80 Scaffold Bracket TRG 120

For assembly of a working and concreting scaffold with MAXIMO and TRIO. Mounted on horizontal and vertical struts.

Technical Data

Permissible load 150 kg/m²
with maximum width of influence 1.35 m.

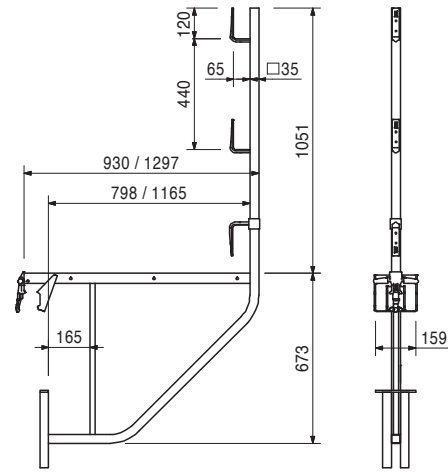
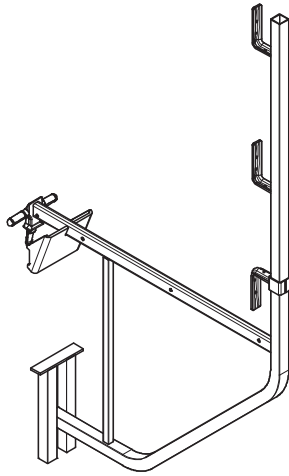

022950	129,000
--------	---------

Concreting Platform TRIO 120 x 270

Working and concreting platform for MAXIMO and TRIO. Attached from above to the panel, self-securing.

Technical Data

Permissible load 150 kg/m².

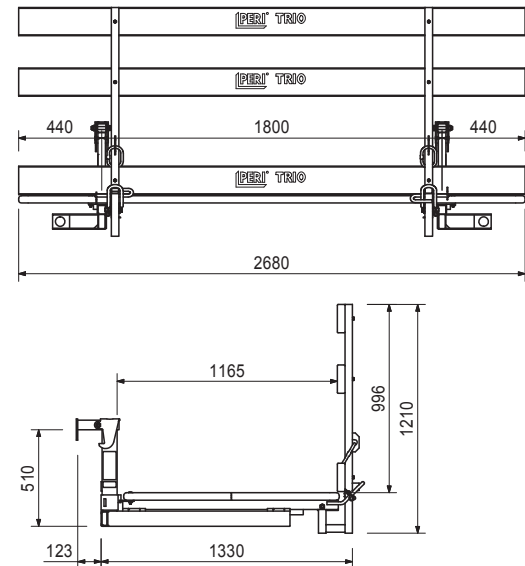
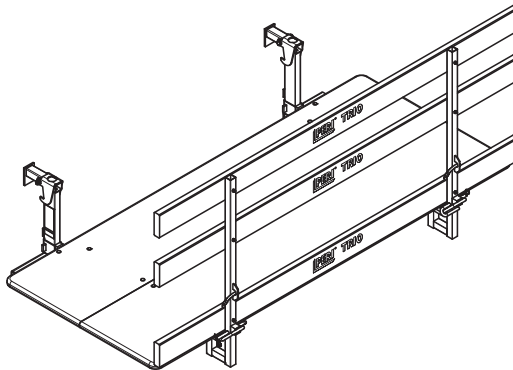

Item no.	Weight kg
101592	2,810

Guardrail Post Holder TRIO
For assembling of a guardrail to TRIO panels.

Complete with
1 pc. 018060 Cotter Pin 4/1, galv.

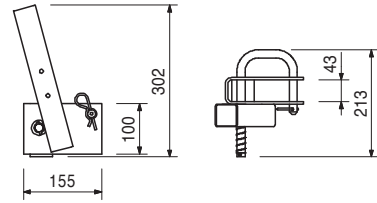
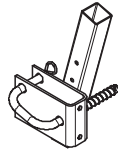

Accessories
Guardrail Post HSGP-2

116292	4,730
--------	-------

Guardrail Post HSGP-2
As guardrail for different systems.

116292	4,730
--------	-------

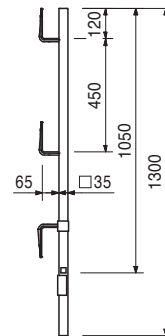

118103 0,700 **Stacking Device L MXA**

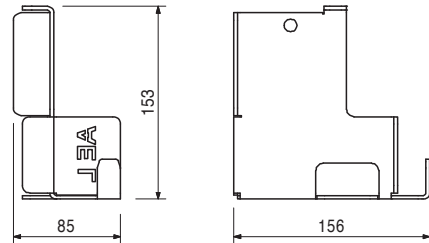
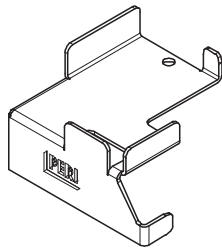

118105 0,699 **Stacking Device R MXA**

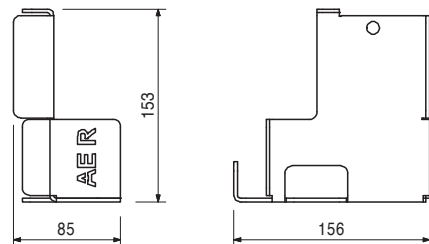
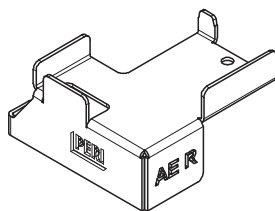

MAXIMO MX 18 Panel Formwork 270 / 330



Item no.	Weight kg
118110	0,614

Stacking Device L MXI

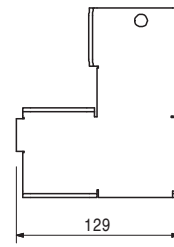
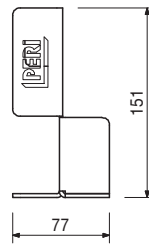
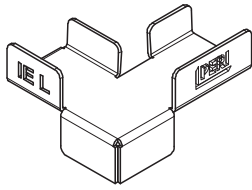

118112	0,613
--------	-------

Stacking Device R MXI

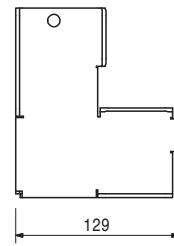
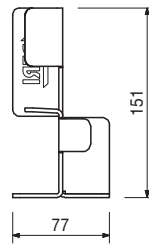
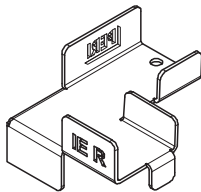

118100	0,652
--------	-------

Stacking Device MX Flat for Shaft Corner MXSE

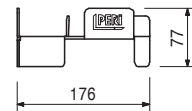
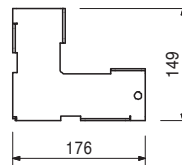
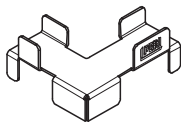

Item no.	Weight kg
027680	49,600

Connector SB-1,2 - MX/TR/D

For assembly of Brace Frame SB-1, 2 to MAXIMO, TRIO and DOMINO panels.

Technical Data

Permissible load-bearing point capacity 1.0 t with crane sling angle $\leq 15^\circ$.

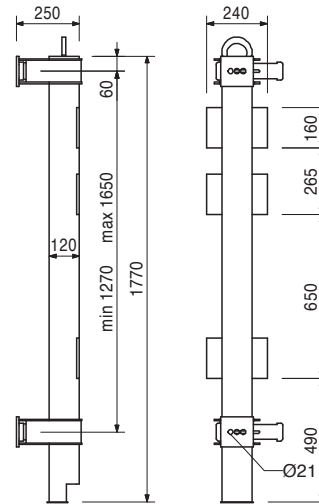

Accessories

027690	0,368	Bolt SB-TRIO/DOMINO, galv.
027590	2,400	Hook Strap for SB-1, 2
113255	0,414	Bolt SB-MAXIMO, galv.
114107	1,190	Sleeve SB-MAXIMO, galv.
114417	1,400	Sleeve SB-MAXIMO WDMX

025740	9,140
--------	-------

Connector SB-A, B, C - MX/TR/D

For connecting MAXIMO, TRIO and DOMINO panels with Brace Frames SB-A0, A, B, C.

Note

1 piece per anchor point.

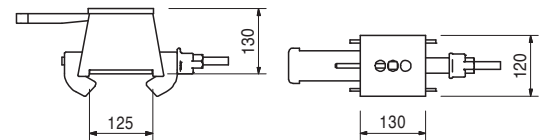
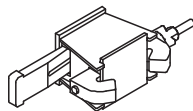

Accessories

027690	0,368	Bolt SB-TRIO/DOMINO, galv.
113255	0,414	Bolt SB-MAXIMO, galv.
114107	1,190	Sleeve SB-MAXIMO, galv.
114417	1,400	Sleeve SB-MAXIMO WDMX

113255	0,414
--------	-------

Bolt SB-MAXIMO, galv.

For connecting MAXIMO panels with Brace Frame SB.

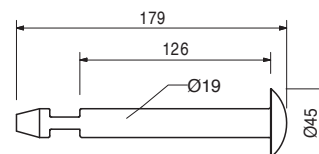
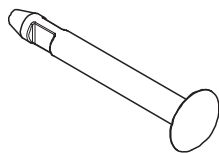

Accessories

114107	1,190	Sleeve SB-MAXIMO, galv.
114417	1,400	Sleeve SB-MAXIMO WDMX

Item no.	Weight kg
114107	1,190

Sleeve SB-MAXIMO, galv.
For connecting MAXIMO panels with Brace Frame SB.

Note
For use with
Sealing Sleeve MX Ø 16 item no. 112342 and
Nut Sealing Sleeve MX Ø 16 item no. 112338.

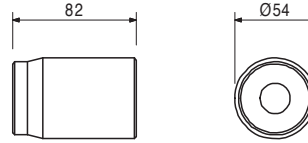
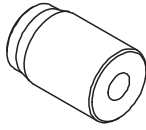

Accessories

113255	0,414
114417	1,400

Bolt SB-MAXIMO, galv.
Sleeve SB-MAXIMO WDMX

114417	1,400
--------	-------

Sleeve SB-MAXIMO WDMX
For connecting MAXIMO panels to Brace Frames SB.

Note
For use with
Sealing Sleeve MX 15 item no. 123603 and
Sealing Sleeve MX 18 item no. 123604.

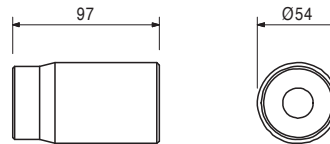
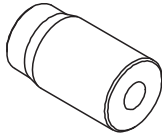

Accessories

113255	0,414
--------	-------

Bolt SB-MAXIMO, galv.

127430	0,104
127488	0,114

Stoppers MX 18
Stopper MX 18 – 75 MF-S
Stopper MX 18 – 75 MF-L

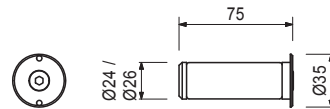
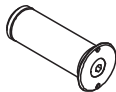

127589	0,082
--------	-------

Stopper MX 18 – 50 MF LS

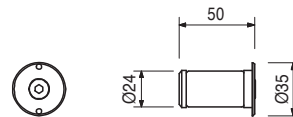

127590	0,077
--------	-------

Stopper MX 18 – 50 OF LS

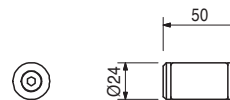

Item no. Weight kg

		Stoppers MX 18
127432	0,099	Stopper MX 18 – 75 OF-S
127490	0,107	Stopper MX 18 – 75 OF-L

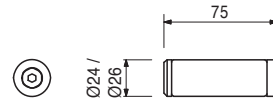
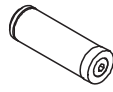

127434	0,038	Stud Spanner MX 18 Contained within the packaging units.
--------	-------	--

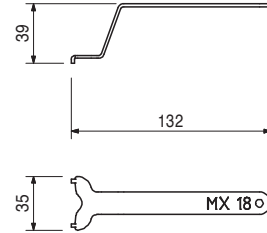
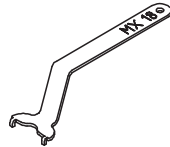

127425	0,160	Magnet Cone MX 18 – 55 For the use with MAXIMO. Use with Anchor MX.
--------	-------	--

Note
For the use with waterproof concrete or architectural concrete.

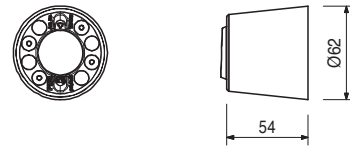
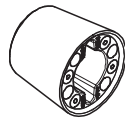

Accessories		
126696	1,220	Magnet Cone Spanner MX 15 / MX 18

031643	0,241	DK Concrete Cone UNI 58/52 For closing anchor points with DK Sealing Cone DW 15/55, DW 20/55, DW 26/55 and SK Anchor Cone DW 15.
--------	-------	--

Note
Delivery unit 50 pieces.

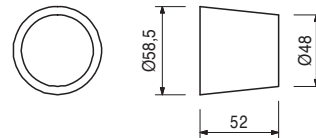
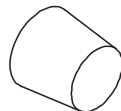

125438	0,024	Spacer MX 18 – 10 mm
--------	-------	-----------------------------

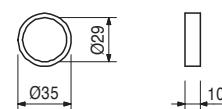

Item no.	Weight kg
126696	1,220

Magnet Cone Spanner MX 15 / MX 18

For dismantling of Magnet Cone MX 15 and MX 18.

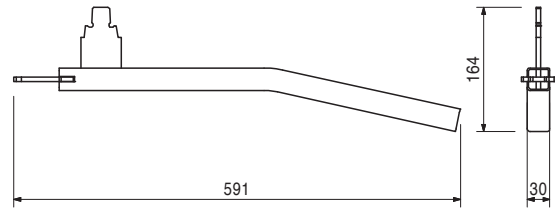
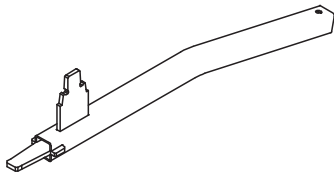

031637	0,055
--------	-------

DK Cone DW 20/55

For waterproof, fire-resistant and soundproof anchor points with Tie Rod DW 20. Use with Spacer Tube rough 28.

Note

Delivery unit 50 pieces.

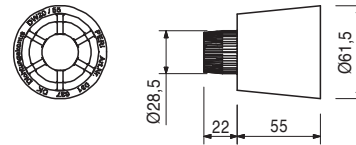

123604	0,015
--------	-------

Sealing MX 18

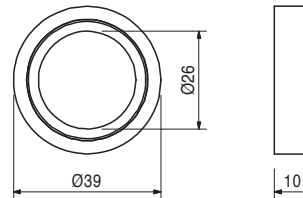

125337	1,390
--------	-------

Extraction Tool MX Sealing

For remove of the Sealing MX 15 and MX 18.

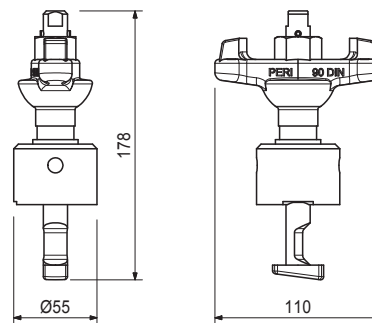
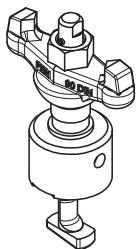

MAXIMO MX 18 Panel Formwork 270 / 330



Item no.	Weight kg
117466	10,600

Push-Pull Prop RS 210, galv.

Extension length $l = 1.30 - 2.10$ m.
For aligning PERI formwork systems and precast concrete elements.

Note

Permissible load see PERI Design Tables.

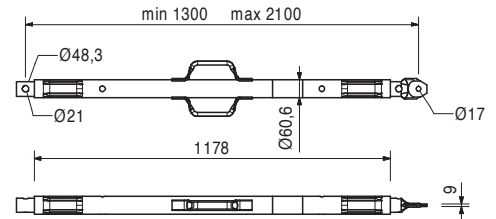
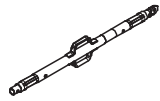

118238	12,200
--------	--------

Push-Pull Prop RS 260, galv.

Extension length $l = 2.30 - 2.60$ m.
For aligning PERI formwork systems and precast concrete elements.

Note

Permissible load see PERI Design Tables.

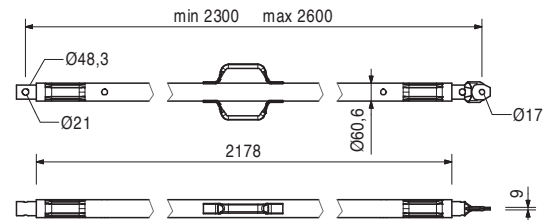
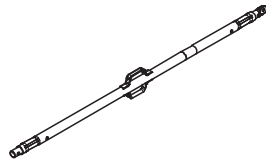

117467	15,500
--------	--------

Push-Pull Prop RS 300, galv.

Extension length $l = 1.90 - 3.00$ m.
For aligning PERI formwork systems and precast concrete elements.

Note

Permissible load see PERI Design Tables.

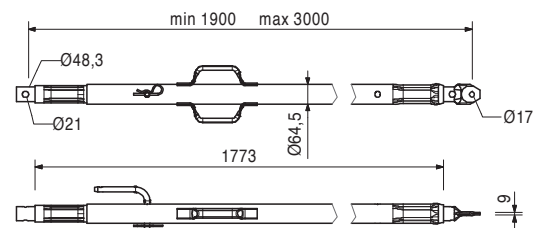
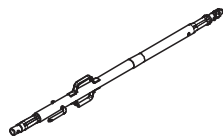

117468	23,000
--------	--------

Push-Pull Prop RS 450, galv.

Extension length $l = 2.80 - 4.50$ m.
For aligning PERI formwork systems and precast concrete elements.

Note

Permissible load see PERI Design Tables.

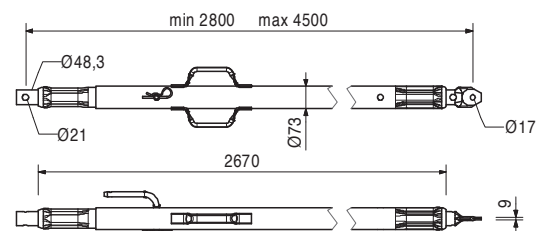
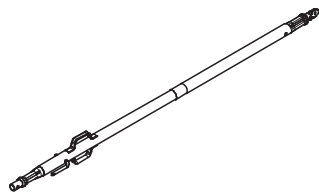

MAXIMO MX 18 Panel Formwork 270 / 330



Item no.	Weight kg
117469	40,000

Push-Pull Prop RS 650, galv.
 Extension length $l = 4.30 - 6.50$ m.
 For aligning PERI formwork systems and precast concrete elements.

Note
 Permissible load see PERI Design Tables.

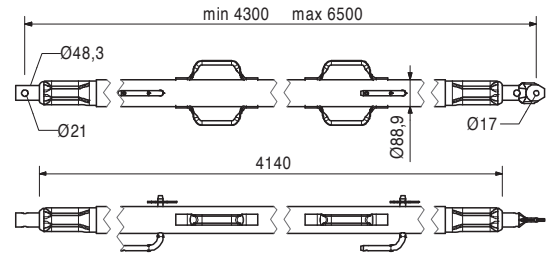
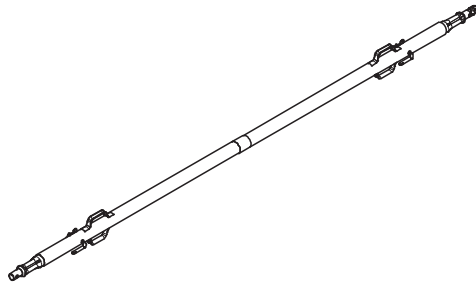

028990	115,000
--------	---------

Push-Pull Prop RS 1000, galv.
 Extension length $l = 6.40 - 10.00$ m.
 For aligning PERI formwork systems.

Note
 Permissible load see PERI Design Tables.

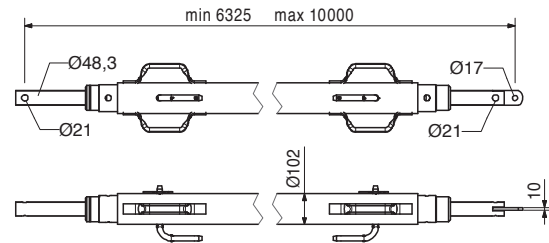
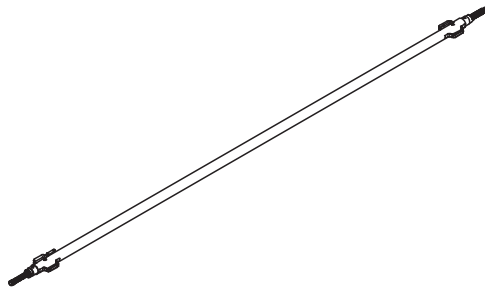

103800	271,000
--------	---------

Push-Pull Prop RS 1400, galv.
 Extension length $l = 6.40 - 14.00$ m.
 For aligning PERI formwork systems.

Note
 Permissible load see PERI Design Tables.
 Chain can be operated from bottom.

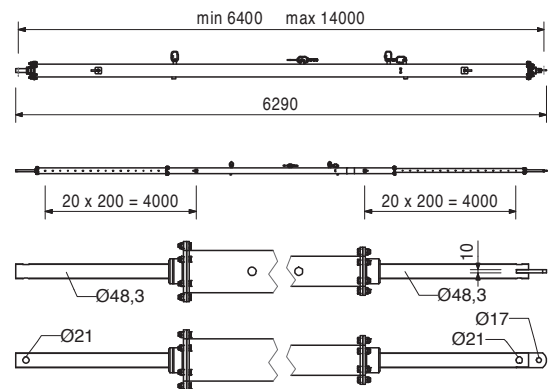
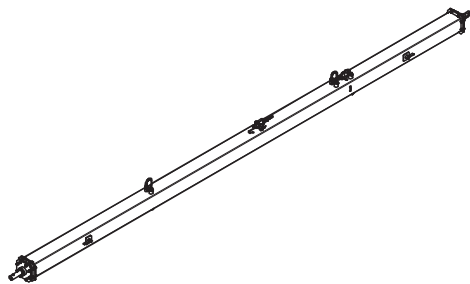

Item no.	Weight kg
117343	3,250

Base Plate-2 for RS 210 – 1400, galv.
For assembly of Push-Pull Props RS 210, 260, 300, 450, 650, 1000 and 1400.

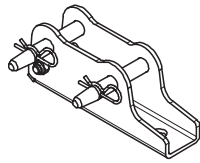

Complete with
2 pc. 105400 Pin \varnothing 20 x 140, galv.
2 pc. 018060 Cotter Pin 4/1, galv.

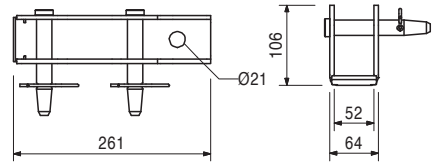

Accessories

124777	0,210
--------	-------

Anchor Bolt PERI 14/20 x 130

028010	17,900
--------	--------

Push-Pull Prop RSS I
Extension length $l = 2.05 - 2.94$ m.
For aligning PERI formwork systems.

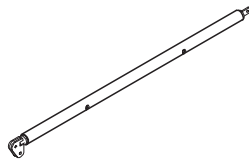

Note
Permissible load see PERI Design Tables.

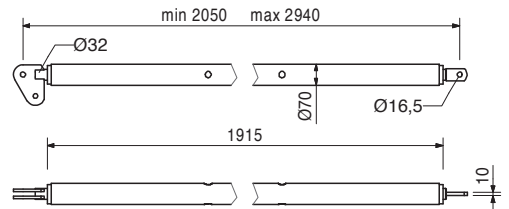

113397	1,600
--------	-------

Spindle Handle RSS / AV
Spindle Handle for screwing on Push-Pull Props RSS I, RSS II, RSS III and Kickers AV 210 and AV 190 complete with 2 bolts and nuts M8.

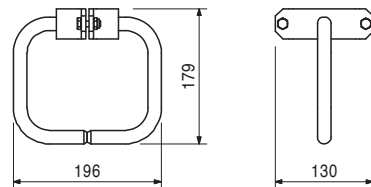
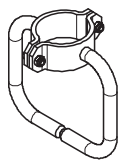

028020	22,000
--------	--------

Push-Pull Prop RSS II
Extension length $l = 2.91 - 3.80$ m.
For aligning PERI formwork systems.

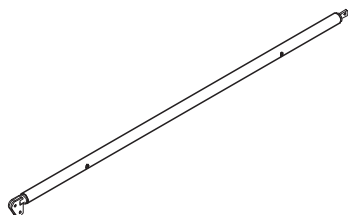

Note
Permissible load see PERI Design Tables.

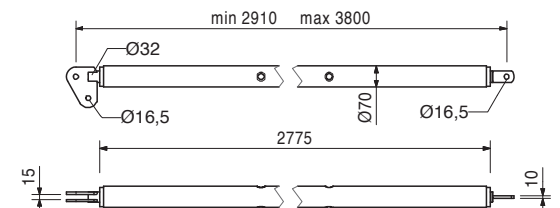

Item no.	Weight kg
028030	38,400

Push-Pull Prop RSS III

Extension length l = 4.60 – 6.00 m.
For aligning PERI formwork systems.

Note

Permissible load see PERI Design Tables.

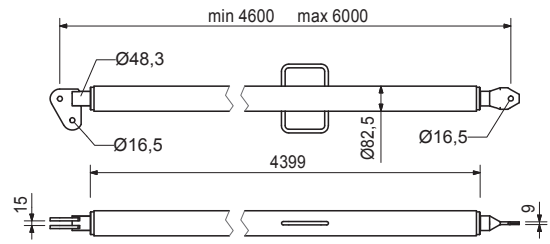
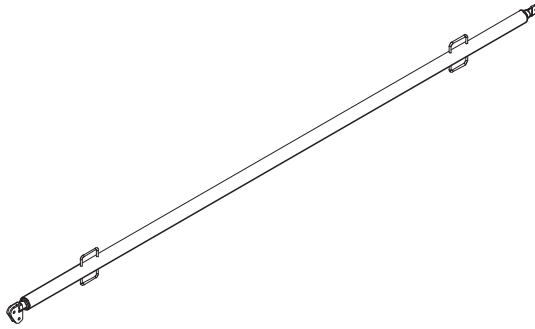

106000	1,820
--------	-------

Base Plate-2 for RSS, galv.

For assembly of RSS Push-Pull Props.

Complete with

1 pc. 027170 Pin Ø 16 x 42, galv.
1 pc. 018060 Cotter Pin 4/1, galv.

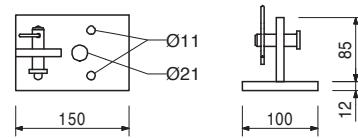
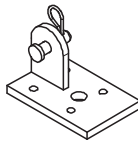

Accessories

124777	0,210
--------	-------

Anchor Bolt PERI 14/20 x 130

057087	3,720
057088	4,410

Kickers AV Kicker AV 82 Kicker AV 111

For aligning PERI formwork systems.

min. L max. L

500	820
790	1110

Complete with

1 pc. 027170 Pin Ø 16 x 42, galv.
1 pc. 018060 Cotter Pin 4/1, galv.

Note

Permissible load see PERI Design Tables.

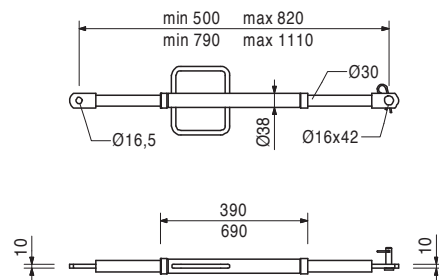
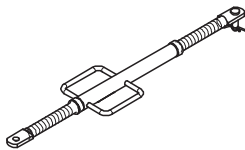

Item no.	Weight kg
028110	5,180

Kicker AV 140

Extension length $l = 1.08 - 1.40$ m.
For aligning PERI formwork systems.

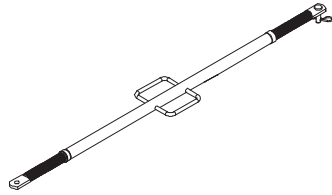

Complete with

1 pc. 027170 Pin $\varnothing 16 \times 42$, galv.
1 pc. 018060 Cotter Pin 4/1, galv.

Note

Permissible load see PERI Design Tables.

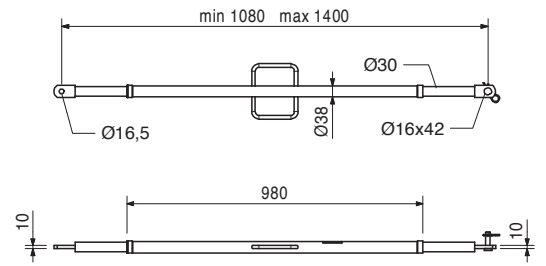

108135	12,900
--------	--------

Kicker AV 210

Extension length $l = 1.28 - 2.10$ m.
For aligning PERI formwork systems.

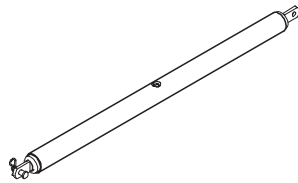

Complete with

1 pc. 027170 Pin $\varnothing 16 \times 42$, galv.
1 pc. 018060 Cotter Pin 4/1, galv.

Note

Permissible load see PERI Design Tables.

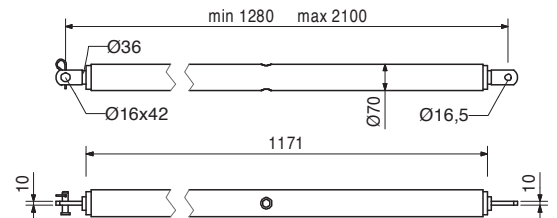

028120	17,000
--------	--------

Kicker AV RSS III

Extension length $l = 2.03 - 2.92$ m.
For aligning PERI formwork systems.

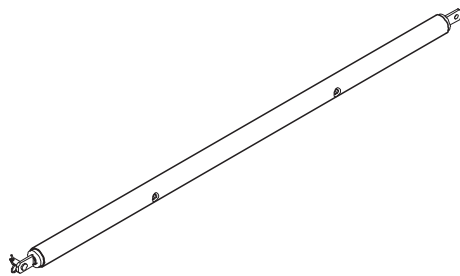

Complete with

1 pc. 027170 Pin $\varnothing 16 \times 42$, galv.
1 pc. 018060 Cotter Pin 4/1, galv.

Note

Permissible load see PERI Design Tables.

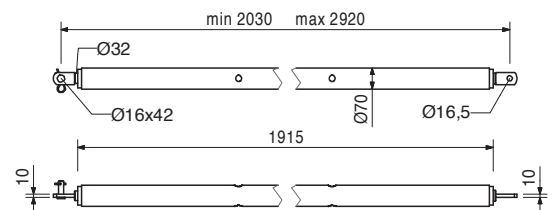

124777	0,210
--------	-------

Anchor Bolt PERI 14/20 x 130

For temporary fixation to reinforced concrete structures.

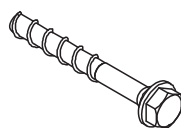

Note

See PERI data sheet!
Drilling $\varnothing 14$ mm.

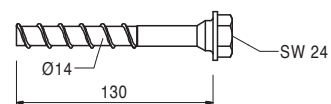



01 Germany
PERI GmbH
 Rudolf-Diesel-Strasse 19
 89264 Weissenhorn
 info@peri.com
 www.peri.com



02 France
 PERI S.A.S.
 77109 Meaux Cedex
 peri.sas@peri.fr
 www.peri.fr

03 Switzerland
 PERI AG
 8472 Ohringen
 info@peri.ch
 www.peri.ch

04 Spain
 PERI S.A.U.
 28110 Algete - Madrid
 info@peri.es
 www.peri.es

05 Belgium/Luxembourg
 N.V. PERI S.A.
 1840 Londerzeel
 info@peri.be
 www.peri.be

06 Netherlands
 PERI Holding B.V.
 5480 AH-Schijndel
 info@peri.nl
 www.peri.nl

07 USA
 PERI Formwork Systems, Inc.
 Elkridge, MD 21075
 info@peri-usa.com
 www.peri-usa.com

08 Indonesia
 PT Beton Perkasa Wijaksana
 Jakarta 10210
 bpw@betonperkasa.com
 www.peri.com

09 Italy
 PERI S.p.A.
 20060 Basiano
 info@peri.it
 www.peri.it

10 Japan
 PERI Japan K.K.
 Tokyo 103-0015
 info@perijapan.jp
 www.perijapan.jp

11 United Kingdom/Ireland
 PERI Ltd.
 Rugby, CV23 0AN
 info@peri.ltd.uk
 www.peri.ltd.uk

12 Turkey
 PERI Kalip ve Iskeleleri Sanayi
 ve Ticaret Ltd.
 Esenyurt / Istanbul 34510
 info@peri.com.tr
 www.peri.com.tr

13 Hungary
 PERI Kft.
 1181 Budapest
 info@peri.hu
 www.peri.hu

14 Malaysia
 PERI Formwork Malaysia Sdn. Bhd.
 43300 Seri Kembangan,
 Selangor Darul Ehsan
 info@perimalaysia.com
 www.perimalaysia.com

15 Singapore
 PERI Asia Pte Ltd
 Singapore 387355
 pha@periasia.com
 www.periasia.com

16 Austria
 PERI Ges.mbh
 3134 Nußdorf ob der Traisen
 office@peri.at
 www.peri.at

17 Czech Republic
 PERI spol. S r.o.
 252 42 Jesenice u Prahy
 info@peri.cz
 www.peri.cz

18 Denmark
 PERI Danmark A/S
 2670 Greve
 peri@peri.dk
 www.peri.dk

19 Finland
 PERI Suomi Ltd. Oy
 05460 Hyvinkää
 info@perisuomi.fi
 www.perisuomi.fi

20 Norway
 PERI Norge AS
 3036 Drammen
 info@peri.no
 www.peri.no

21 Poland
 PERI Polska Sp. z o.o.
 05-860 Płochocin
 info@peri.com.pl
 www.peri.com.pl

22 Sweden
 PERIform Sverige AB
 30262 Halmstad
 peri@periform.se
 www.periform.se

23 Korea
 PERI (Korea) Ltd.
 Seoul 06243
 info@perikorea.com
 www.perikorea.com

24 Portugal
 Pericofragens Lda.
 2790-326 Queijas
 info@peri.pt
 www.peri.pt

25 Argentina
 PERI S.A.
 B1625GPA Escobar – Bs. As.
 info@peri.com.ar
 www.peri.com.ar

26 Brazil
 PERI Formas e
 Escoramentos Ltda.
 Vargem Grande Paulista – SP
 info@peribrasil.com.br
 www.peribrasil.com.br

27 Chile
 PERI Chile Ltda.
 Colina, Santiago de Chile
 perichile@peri.cl
 www.peri.cl

28 Romania
 PERI România SRL
 077015 Balotești
 info@peri.ro
 www.peri.ro

29 Slovenia
 PERI Agency
 2000 Maribor
 peri.slo@triera.net
 www.peri.com

30 Slovakia
 PERI spol. s. r.o.
 903 01 Senec
 info@peri.sk
 www.peri.sk

31 Australia
 PERI Australia Pty. Ltd.
 Glendenning NSW 2761
 info@periaus.com.au
 www.periaus.com.au

32 Estonia
 PERI AS
 76406 Saku vald
 Harjumaa
 peri@peri.ee
 www.peri.ee

33 Greece
 PERI Hellas Solely Owned Ltd.
 194 00 Koropi
 info@perihellas.gr
 www.perihellas.gr

34 Latvia
 PERI SIA
 2118 Salaspils novads, Rigas rajons
 info@peri-latvija.lv
 www.peri-latvija.lv

35 United Arab Emirates
 PERI (L.L.C.)
 Dubai U.A.E.
 perillc@perime.com
 www.perime.com

36 Canada
 PERI Formwork Systems, Inc.
 Bolton, ON – L7E 1K1
 info@peri.ca
 www.peri.ca



- | | | | | |
|---|---|---|--|--|
| <p>37 Lebanon
PERI Lebanon Sarl
90416 – Jdeideh
lebanon@peri.de</p> | <p>44 Russian Federation
OOO PERI
142407, Noginsk District
moscow@peri.ru
www.peri.ru</p> | <p>51 Turkmenistan
PERI Kalıp ve İskeleleri
Aşgabat
ahmet.kadioglu@peri.com.tr
www.peri.com.tr</p> | <p>57 Saudi Arabia
PERI Saudi Arabia Ltd.
21463 Jeddah
info@peri.com.sa
www.peri.com.sa</p> | <p>64 Nigeria
PERI Nigeria Ltd.
Lagos
info@peri.ng
www.peri.ng</p> |
| <p>38 Lithuania
PERI UAB
02300 Vilnius
info@peri.lt
www.peri.lt</p> | <p>45 South Africa
PERI (Pty) Ltd
7600 Stellenbosch
info@peri.co.za
www.peri.co.za</p> | <p>52 Belorussia
IOOO PERI Belarus
220100 Minsk
info@peri.by
www.peri.by</p> | <p>58 Qatar
PERI Qatar LLC
P.O.Box: 31295 - Doha
info@periqatar.com
www.peri.qa</p> | <p>65 Oman
PERI (L.L.C.)
Muscat
perimct@perime.com
www.perime.com</p> |
| <p>39 Morocco
PERI S.A.U.
Tanger
info@peri.ma
www.peri.ma</p> | <p>46 Ukraine
PERI Ukraina
07400 Brovary
peri@peri.ua
www.peri.ua</p> | <p>53 Croatia
PERI oplate i skele d.o.o.
10 250 Lučko-Zagreb
info@peri.com.hr
www.peri.com.hr</p> | <p>59 Algeria
PERI PERI
Kouba 16092, Alger
info@peri.com
www.peri.com</p> | <p>66 Colombia
PERI S.A.S. Colombia
Briceño, Cundinamarca
peri.colombia@peri.com.co
www.peri.com.co</p> |
| <p>40 Israel
PERI Formwork
Engineering Ltd.
Rosh Ha'ayin, 48104
info@peri.co.il
www.peri.co.il</p> | <p>47 Egypt
PERI Branch Office
11341 Nasr City /Cairo
info@peri.com.eg
www.peri.com.eg</p> | <p>54 India
PERI (India) Pvt Ltd
Mumbai – 400064
info@peri.in
www.peri.in</p> | <p>60 Albania
PERI Representative Office
Tirane
info@peri.com.tr
www.peri.com.tr</p> | <p>67 Philippines
PERI-Asia Philippines, INC.
Makati City
info@peri.com.ph
www.peri.com.ph</p> |
| <p>41 Bulgaria
PERI Bulgaria EOOD
1839 Sofia
peri.bulgaria@peri.bg
www.peri.bg</p> | <p>48 Serbia
PERI – Oplate d.o.o.
22310 Šimanovci
office@peri.rs
www.peri.rs</p> | <p>55 Jordan
PERI GmbH - Jordan
11947 Amman
jordan@peri.com
www.peri.com</p> | <p>61 Peru
PERI Peruana S.A.C.
Villa El Salvador, Lima
contacto@peri.com.pe
www.peri.com.pe</p> | <p>68 Hong Kong
PERI (Hong Kong) Limited
Hong Kong SAR, PRC
bob.dover@periasia.com
www.perihk.com</p> |
| <p>42 Iceland
Armar ehf.
220 Hafnarfjörður
armar@armar.is
www.armar.is</p> | <p>49 Mexico
PERI Cimbras y Andamios,
S.A. de C.V.
Estado de México, Huehuetoca
info@peri.com.mx
www.peri.com.mx</p> | <p>56 Kuwait
PERI Kuwait W.L.L.
13011 Kuwait
info@peri.com.kw
www.peri.com.kw</p> | <p>62 Panama
PERI Panama Inc.
0832-00155 Panama City
info@peri.com.pa
www.peri.com.pa</p> | <p>69 Namibia
PERI (Pty.) Ltd.
Windhoek
windhoek@peri.na
www.peri.na</p> |
| <p>43 Kazakhstan
TOO PERI Kazakhstan
050000 Almaty
peri@peri.kz
www.peri.kz</p> | <p>50 Azerbaijan
PERI Representative Office
Baku
peribaku@peri.com.tr
www.peri.com.tr</p> | <p>63 Angola
Pericofragens, Lda.
Luanda
renato.portugal@peri.pt
www.peri.pt</p> | <p>70 Mozambique
PERI (Pty.) Ltd.
Matola
maputo@peri.co.mz
www.peri.co.mz</p> | |

The optimal System for every Project and every Requirement



Wall Formwork



Column Formwork



Slab Formwork



Climbing Systems



Tunnel Formwork



Bridge Formwork



Shoring Systems



Construction Scaffold



Facade Scaffold



Industrial Scaffold



Access



Protection Scaffold

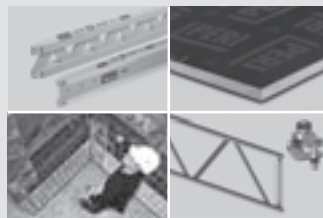

System-Independent Accessories



Services



PERI GmbH
Formwork Scaffolding Engineering
 Rudolf-Diesel-Strasse 19
 89264 Weissenhorn
 Germany
 Tel. +49 (0)7309.950-0
 Fax +49 (0)7309.951-0
 info@peri.com
 www.peri.com